

Lectures on Poisson Geometry

Marius Crainic
Rui Loja Fernandes
Ioan Mărcuț

This is a preliminary version of the book [Lectures on Poisson Geometry](#) published by the American Mathematical Society (AMS). This preliminary version is made available with the permission of the AMS and may not be changed, edited, or reposted at any other website without explicit written permission from the author and the AMS.

To our families

Contents

| | |
|---|------|
| Preface | xiii |
| List of Notations and Symbols | xvii |
| List of Conventions | xix |
| Part 1. Basic Concepts | |
| Chapter 1. Poisson Brackets | 3 |
| §1.1. Poisson brackets | 3 |
| §1.2. Orbits | 5 |
| §1.3. Poisson and Hamiltonian diffeomorphisms | 6 |
| §1.4. Examples | 8 |
| §1.5. Poisson actions and quotients | 14 |
| Problems | 19 |
| Chapter 2. Poisson Bivectors | 23 |
| §2.1. The point of view of bivectors | 23 |
| §2.2. A slight twist: π^\sharp | 28 |
| §2.3. Poisson maps and bivector fields | 30 |
| §2.4. Examples | 31 |
| Problems | 40 |
| Chapter 3. Local Structure of Poisson Manifolds | 43 |
| §3.1. The Weinstein Splitting Theorem | 43 |
| §3.2. Regular points | 46 |

| | |
|--|-----|
| §3.3. Singular points | 47 |
| §3.4. The isotropy Lie algebra | 50 |
| §3.5. Linearization of Poisson structures | 53 |
| Problems | 55 |
| Notes and References for Part 1 | 59 |
| Part 2. Poisson Geometry Around Leaves | |
| Chapter 4. Symplectic Leaves and the Symplectic Foliation | 63 |
| §4.1. The symplectic foliation | 63 |
| §4.2. Regular Poisson structures | 69 |
| §4.3. More examples of symplectic foliations | 73 |
| §4.4. The coupling construction | 76 |
| Problems | 81 |
| Chapter 5. Poisson Transversals | 85 |
| §5.1. Slices and Poisson transversals | 85 |
| §5.2. The transverse Poisson structure to a leaf | 91 |
| §5.3. Poisson maps and Poisson transversals | 95 |
| Problems | 97 |
| Chapter 6. Symplectic Realizations | 101 |
| §6.1. Definition | 101 |
| §6.2. Examples | 103 |
| §6.3. Symplectic realizations of linear Poisson structures | 111 |
| §6.4. Libermann's Theorem and dual pairs | 117 |
| §6.5. Local existence | 124 |
| Problems | 129 |
| Chapter 7. Dirac Geometry | 133 |
| §7.1. Constant Dirac structures | 134 |
| §7.2. Dirac structures | 137 |
| §7.3. Pullbacks of Dirac structures | 142 |
| §7.4. Pushforwards of Dirac structures | 145 |
| §7.5. Gauge equivalences | 149 |
| Problems | 153 |

| | |
|---|-----|
| Chapter 8. Submanifolds in Poisson Geometry | 157 |
| §8.1. Poisson submanifolds | 157 |
| §8.2. Poisson-Dirac submanifolds | 165 |
| §8.3. Coregular Poisson-Dirac submanifolds | 169 |
| §8.4. Coisotropic submanifolds | 172 |
| §8.5. Example: Fixed point sets | 180 |
| §8.6. Pre-Poisson submanifolds | 184 |
| Problems | 189 |
| Notes and References for Part 2 | 193 |
| Part 3. Global Aspects | |
| Chapter 9. Poisson Cohomology | 197 |
| §9.1. The cotangent Lie algebroid | 197 |
| §9.2. The Poisson differential and Poisson cohomology | 200 |
| §9.3. Low degrees | 201 |
| §9.4. Shadows of Poisson cohomology | 206 |
| §9.5. The cohomological obstruction to linearization | 213 |
| Problems | 218 |
| Chapter 10. Poisson Homotopy | 223 |
| §10.1. Cotangent paths | 223 |
| §10.2. Cotangent maps | 225 |
| §10.3. Integration and the contravariant Stokes Theorem | 228 |
| §10.4. Cotangent path-homotopy | 231 |
| §10.5. Poisson homotopy and homology groups | 237 |
| §10.6. Variation of symplectic area | 245 |
| Problems | 249 |
| Chapter 11. Contravariant Geometry and Connections | 253 |
| §11.1. Contravariant connections on vector bundles | 253 |
| §11.2. Parallel transport along cotangent paths | 256 |
| §11.3. Flat contravariant connections | 260 |
| §11.4. Geodesics for contravariant connections | 265 |
| §11.5. Existence of symplectic realizations | 269 |
| Problems | 273 |
| Notes and References for Part 3 | 277 |

Part 4. Symplectic Groupoids

| | |
|---|-----|
| Chapter 12. Complete Symplectic Realizations | 283 |
| §12.1. The infinitesimal action | 284 |
| §12.2. Case study: Linear Poisson structures | 286 |
| §12.3. Case study: The zero Poisson structure | 288 |
| §12.4. Case study: Nondegenerate Poisson structures | 290 |
| §12.5. Completeness | 293 |
| §12.6. The Poisson homotopy groupoid | 299 |
| §12.7. Lagrangian fibrations | 302 |
| Problems | 309 |
| Chapter 13. A Crash Course on Lie Groupoids | 313 |
| §13.1. Lie groupoids | 313 |
| §13.2. Lie groupoids: Examples and basic constructions | 316 |
| §13.3. The Lie algebroid of a Lie groupoid | 326 |
| §13.4. Lie algebroids: Examples and basic constructions | 330 |
| §13.5. Duals of Lie algebroids | 339 |
| §13.6. The Lie philosophy | 345 |
| §13.7. The non-Hausdorff setting | 348 |
| Problems | 357 |
| Chapter 14. Symplectic Groupoids | 361 |
| §14.1. Symplectic groupoids and Poisson structures | 361 |
| §14.2. Examples | 368 |
| §14.3. Integrability of Poisson structures I | 377 |
| §14.4. Symplectic groupoid actions | 388 |
| §14.5. Hausdorffness issues | 393 |
| §14.6. The Poisson homotopy groupoid | 395 |
| §14.7. Morita equivalence | 405 |
| §14.8. Integrability of Poisson structures II | 408 |
| Problems | 414 |
| Notes and References for Part 4 | 419 |

Part 5. Appendices

| | |
|--|-----|
| Appendix A. Lie Groups | 425 |
| §A.1. Lie groups | 425 |
| §A.2. Lie group actions | 428 |
| §A.3. Time-dependent vector fields | 433 |
| Appendix B. Symplectic Structures | 437 |
| §B.1. Symplectic forms | 437 |
| §B.2. Symplectic and Hamiltonian actions | 441 |
| Appendix C. Foliations | 447 |
| §C.1. Regular foliations | 447 |
| §C.2. Foliated differential forms | 452 |
| §C.3. Singular foliations | 454 |
| Appendix D. Groupoids: Conventions and Choices | 459 |
| Bibliography | 463 |
| Index | 473 |

Preface

The aim of this book is to provide an introduction to Poisson geometry. The book grew out of several sets of lecture notes that we prepared over many years while teaching master- and graduate-level courses at our home institutions and minicourses at various Poisson geometry schools. In particular, the writing of the book was influenced by our experiences teaching the material and by the interactions we had with the students who attended those lectures. Although it is fair to say that the book has grown and includes a bit more material than one can actually hope to cover in class during a one-semester course, the aim remains the same: to provide lecture notes for a graduate-level course giving an introduction to Poisson geometry, addressed to students and researchers who have some familiarity with classical differential geometry and differentiable manifolds. Some basic knowledge of algebraic topology and symplectic geometry would be a plus, but not a requirement, to fully grasp some parts of the book. Some standard topics from differential geometry that we need but that might be missing from an introductory course are summarized in the appendices at the end of the text.

Poisson geometry emerged from the mathematical formulation of classical mechanics. Historically, it all started with the work of Siméon Denis Poisson on the mechanics of particles which led him to the discovery in 1809 of the so-called Poisson bracket as a method for obtaining new integrals of motion. Poisson computations occupied many pages, and his results were rediscovered and simplified two decades later by Carl Gustav Jacob Jacobi, who was the first to realize the fundamental role played by the Poisson bracket in rational mechanics and who identified its main properties: an operation (bracket) which associates to any two observables f and g a

new observable $\{f, g\}$ and which satisfies the Leibniz and Jacobi identity. Jacobi's work on Poisson brackets, including the discovery of his famous identity, the commutator of derivations, etc., greatly influenced Sophus Lie in his foundational study of symmetries of partial differential equations at the end of the nineteenth century, which led him to the discovery of Lie groups and Lie algebras (see [102]). *Linear* Poisson structures correspond to Lie algebra structures, so Lie was in fact the first to study them and it is remarkable how deeply Lie's work dives into Poisson geometric aspects. For instance, Lie explicitly poses the realization problem for linear Poisson structures, a problem which turns out to be the same as that of searching for a Lie group integrating a Lie algebra. However, perhaps somewhat surprisingly, the first geometric, systematic, study of Poisson structures occurred much more recently in the work of André Lichnerowicz [109] in the 1970s, which marks the birth of Poisson *geometry* in its modern formulation.

The spectacular development of Poisson geometry from the last few decades owes much to the foundational work of Alan Weinstein [147] in the 1980s and his discovery of symplectic groupoids as the global objects behind Poisson structures [151]. In retrospect, this discovery follows the same path as in Lie's work: the search for nondegenerate (symplectic) realizations led to the discovery of interesting global structures. In some sense, this book can be seen as an updated and expanded exposition of Weinstein's pioneering work. In particular, our aim here is not to provide a survey of the vast amount of work done in this subject in the last 30–40 years, but rather to provide an introduction to the subject that will allow the reader to plunge into any of these recent exciting developments, some of which are mentioned throughout the text.

We have tried to provide our own insight into the subject while resisting the temptation of concentrating on our contributions. Our philosophy can be summarized as follows: Poisson geometry is an amalgam of foliation theory (partition into leaves), symplectic geometry (along the leaves), and Lie theory (transverse to the leaves). In particular, it provides the framework in which these geometries get to interact with each other in a beautiful symbiosis. While this is already, we believe, the main message in Weinstein's foundational paper [147], the full extent of this interaction came to life later with the discovery of the global counterparts to Poisson structures: *symplectic Lie groupoids*. These objects codify all these three different aspects and we have organized the book so that one is led naturally to uncover them, giving an upgraded view on Weinstein's and Lichnerowicz's works.

The monograph by Vaisman [141] was for a long period of time the only textbook on Poisson geometry, apart from an earlier account by Bhaskara and Viswanath [15]. The book by Cannas da Silva and Weinstein [30] contains a nice elementary introduction to the subject, aimed towards noncommutative geometry and quantization. A more up-to-date account of Poisson geometry, with a strong emphasis on local normal forms, was provided by Dufour and Zung in their research monograph [59]. More recently, the beautiful book by Laurent-Gengoux, Pichereau, and Vanhaecke appeared [105], which is highly recommended for people with an algebraic-geometric background. As the authors point out in the introduction, “The main topic about Poisson structures which is absent from this book is what should be called Poisson geometry.” We hope that our book provides an introduction to Poisson geometry, which can be assimilated during a semester-long course or can be used as material for self-study of the topic.

The main body of the book is divided into four parts, followed by the appendices that were already mentioned. Each part ends with a small set of notes containing brief historical comments and directions for further reading. The best overview of the book is its table of contents. Still, we would like to emphasize that we paid special attention to the way we introduce those basic concepts in the theory that are more complex and require a deeper thought process. Take for example the notion of symplectic leaf: set-theoretically, we introduce them right away in Chapter 1 as the orbits of Hamiltonian diffeomorphisms, promising the reader that the actual structure (smooth, symplectic) will be discussed later. In Chapter 2, we take advantage of the bivector field point of view to indicate how the smooth structure may arise from a Frobenius-type theorem. However, the actual local result that is needed, the Weinstein Splitting Theorem, is then dealt with in Chapter 3. Finally, we discuss properly their smooth and symplectic structure in Chapter 4. We have also paid special attention to examples and exercises — at the price of increasing the size of the book. Several sections of the book are called “Examples” or “Case study”, and there are well over 200 exercises, split into two types: the ones spread throughout the text, called “Exercises”, which are helpful in understanding the main material, and the ones listed at the end of each chapter, called “Problems”, which are useful in consolidating the material and providing further examples. We have tried to fill in a gap in the existing literature by providing a longer list of concrete examples of symplectic realizations and symplectic groupoids. The end of each example is marked with the symbol of a fish. We have made an effort to include full proofs for all the results we discuss, the exception being Lie’s Third Theorem for Lie algebroids. Some of the arguments used in the proofs are new; others simplify and fill in some gaps in the literature (see the notes and references at the end of each part of the book).

There are a few topics, which may now be considered standard in Poisson geometry, that we have decided not to include, such as Poisson-Lie groups, deformation quantization, generalized complex structures and integrable systems. They go beyond our purpose here and they deserve a separate volume. We hope that our book will provide a solid background for learning such topics or for moving to more advanced ones in the cutting edge of research.

Acknowledgments. We would like to express our appreciation to the many students, in particular to our PhD students, who took part in the various courses on Poisson geometry we have taught in Utrecht, Urbana-Champaign, and Nijmegen, as well as in various summer schools on Poisson geometry. Their comments and feedback were invaluable to the writing of this book.

There are many colleagues and collaborators with whom we have interacted throughout the years. These interactions have shaped our views of Poisson geometry and mathematics in general, and from them we obtained many ideas which have influenced the writing of this book. We are grateful to all of them!

We would also like to thank our home institutions for providing a stimulating atmosphere and work environment and for their welcoming hospitality during our mutual visits.

We have been generously supported by the NWO and NSF during the writing of this book, most recently by NWO Vici grant 639.033.312 and NSF grant DMS-2003223.

March 11, 2021

Marius Crainic
Rui Loja Fernandes
Ioan Mărcuț

List of Notations and Symbols

List of notations, abbreviations, symbols, and the like:

| | |
|------------------------------------|---|
| M | : smooth manifold |
| $x \in M$ | : a point in the manifold M |
| $C^\infty(M)$ | : smooth functions on M |
| $\mathfrak{X}^k(M)$ | : multivector fields of degree k on M |
| $\Omega^k(M)$ | : differential forms of degree k on M |
| $\Omega_{\text{cl}}^k(M)$ | : closed differential forms of degree k on M |
| $\text{Diff}(M)$ | : diffeomorphisms of M |
| i_X, i_α | : interior product by a vector field X , by a 1-form α |
| \mathcal{L}_X | : Lie derivative along a vector field X |
| $[\cdot, \cdot]$ | : Schouten bracket of multivector fields |
| ϕ_X^t | : flow of the vector field X |
| $\Phi_X^{t,s}$ | : flow of the time-dependent vector field $X = \{X_t\}_{t \in I}$ |
| $d_x f$ | : differential of the function f at the point x |
| θ_L | : Liouville 1-form on T^*M |
| ω_{can} | : canonical symplectic form on T^*M |
| (M, π) | : Poisson manifold |
| $\pi^\sharp : T^*M \rightarrow TM$ | : contraction with a bivector field π |
| $\mathfrak{X}(M, \pi)$ | : Poisson vector fields of (M, π) |

| | |
|---|--|
| $\mathfrak{X}_{\text{Ham}}(M, \pi)$ | : Hamiltonian vector fields of (M, π) |
| $\text{Diff}(M, \pi)$ | : Poisson diffeomorphisms of (M, π) |
| $\text{Ham}(M, \pi)$ | : Hamiltonian diffeomorphisms of (M, π) |
| \mathcal{F}_π | : symplectic foliation of (M, π) |
| \mathfrak{g}, G | : Lie algebra, Lie group |
| $V^\circ \subset W^*$ | : annihilator of the linear subspace $V \subset W$ |
| $\mathcal{G} \rightrightarrows M$ | : Lie groupoid over M with source \mathbf{s} , target \mathbf{t} , multiplication \mathbf{m} , unit \mathbf{u} , and inverse ι |
| $A \rightarrow M$ | : Lie algebroid over M with Lie bracket $[\cdot, \cdot]_A$ and anchor ρ_A (or without the index A) |
| $\overleftarrow{v}, \overleftarrow{\alpha}$ | : left-invariant vector fields on a Lie group or groupoid |
| $\overrightarrow{v}, \overrightarrow{\alpha}$ | : right-invariant vector fields on a Lie group or groupoid |
| \mathcal{A} | : action of Lie group or groupoid |
| \mathfrak{a} | : action of Lie algebra or algebroid |
| $(\Sigma, \Omega) \rightrightarrows M$ | : symplectic groupoid over M |
| $\sigma_\Omega : A \xrightarrow{\simeq} T^*M$ | : Lie algebroid isomorphism of $(\Sigma, \Omega) \rightrightarrows M$ |
| $\mathbb{T}M$ | : generalized tangent bundle $TM \oplus T^*M$ |
| $d\Phi : \mathbb{T}M \rightarrow \mathbb{T}N$ | : generalized differential of a diffeomorphism Φ |
| \mathbb{L} | : Dirac structure |
| $e^B\pi, e^B\mathbb{L}$ | : gauge transform of π, \mathbb{L} |
| $\Phi^!\mathbb{L}, \Phi_!\mathbb{L}$ | : pullback, pushforward of \mathbb{L} |
| $E, m_t : E \rightarrow E$ | : vector bundle, scalar multiplication by t |

List of Conventions

All manifolds are smooth, second countable, and all maps are smooth. Manifolds will also be assumed to be Hausdorff, unless otherwise stated — see Sections 13.7 and 14.5. A topological space is said to be 1-connected if it is connected and simply connected. Vector spaces are real, unless stated otherwise.

- **Lie bracket of vector fields:** $[X, Y](f) = X(Y(f)) - Y(X(f))$
- **Lie algebra of G :** left-invariant vector fields on G
- **Actions $G \times M \rightarrow M$:** all actions are left actions unless stated otherwise
- **Infinitesimal actions:** Lie algebra homomorphisms $\mathfrak{a} : \mathfrak{g} \rightarrow \mathfrak{X}(M)$
- **Infinitesimal generators:** the infinitesimal action associated to a G -action: $\mathfrak{a}(v)|_x := \left. \frac{d}{dt} \right|_{t=0} \exp(-tv) \cdot x$
- **Contractions:** $i_\alpha \vartheta = \vartheta(\alpha, -)$ and $i_v \omega = \omega(v, -)$
- **Canonical symplectic form:** $\omega_{\text{can}} = -d\theta_L$, with θ_L the Liouville 1-form
- **Symplectic form/bivector:** $\pi^\sharp = (\omega^\flat)^{-1}$
- **Hamiltonian vector field (M, ω) :** $i_{X_f} \omega = df$
- **Poisson bracket on (M, ω) :** $\{f, g\} = X_f(g)$
- **Hamiltonian vector field (M, π) :** $X_f = \pi^\sharp(df) = i_{df} \pi = \{f, \cdot\}$
- **Multiplication in groupoid \mathcal{G} :** $g \cdot h$ is defined if $\mathfrak{s}(g) = \mathfrak{t}(h)$ and the result satisfies $\mathfrak{s}(g \cdot h) = \mathfrak{s}(h)$ and $\mathfrak{t}(g \cdot h) = \mathfrak{t}(g)$
- **Lie algebroid of \mathcal{G} :** left-invariant vector fields, so $A_x = (\text{Ker } d\mathfrak{t})|_x$
- **Symplectic groupoid (Σ, Ω) :** $\mathfrak{t} : (\Sigma, \Omega) \rightarrow (M, \pi)$ is a Poisson map

Part 1

Basic Concepts

In these first lectures we discuss the building blocks of Poisson geometry. We introduce the two standard ways of conceptualizing Poisson manifolds, via Poisson brackets and via Poisson bivector fields. After that we discuss the main examples, which will be used throughout the book.

Poisson Brackets

1.1. Poisson brackets

Definition 1.1. A **Poisson manifold** is a manifold M endowed with a **Poisson bracket** on the space $C^\infty(M)$ of smooth functions, i.e., a Lie bracket

$$\{\cdot, \cdot\} : C^\infty(M) \times C^\infty(M) \rightarrow C^\infty(M),$$

satisfying the Leibniz identity:

$$\{f, g \cdot h\} = g \cdot \{f, h\} + \{f, g\} \cdot h, \quad \forall f, g, h \in C^\infty(M).$$

A **Poisson map** between Poisson manifolds $(M_1, \{\cdot, \cdot\}_1)$ and $(M_2, \{\cdot, \cdot\}_2)$ is a smooth map $\Phi : M_1 \rightarrow M_2$ which induces a Lie algebra homomorphism:

$$\{f \circ \Phi, g \circ \Phi\}_1 = \{f, g\}_2 \circ \Phi, \quad \forall f, g \in C^\infty(M_2).$$

Recall that $(C^\infty(M), \{\cdot, \cdot\})$ being a **Lie algebra** means that the Poisson bracket is \mathbb{R} -bilinear and skew-symmetric and satisfies the **Jacobi identity**:

$$\{f, \{g, h\}\} + \{h, \{f, g\}\} + \{g, \{h, f\}\} = 0, \quad \forall f, g, h \in C^\infty(M).$$

The **Leibniz identity** says that, for any $H \in C^\infty(M)$, the operation $\{H, \cdot\}$ is a derivation of the algebra $C^\infty(M)$; therefore it defines a vector field X_H on M via the relation

$$(1.1) \quad \{H, f\} = \mathcal{L}_{X_H}(f), \quad \forall f \in C^\infty(M).$$

This is called the **Hamiltonian vector field** of $H \in C^\infty(M)$.

A consequence of the Leibniz rule is that Poisson brackets are local in the sense that they can be restricted to open sets.

Proposition 1.2. *Any open subset U of a Poisson manifold $(M, \{\cdot, \cdot\})$ has an induced Poisson bracket $\{\cdot, \cdot\}_U$ for which the inclusion $U \hookrightarrow M$ is a Poisson map:*

$$\{f|_U, g|_U\}_U = \{f, g\}|_U, \quad \forall f, g \in C^\infty(M).$$

Proof. For $f, g \in C^\infty(U)$ and $p \in U$ we define

$$\{f, g\}_U(p) := \{\tilde{f}, \tilde{g}\}(p),$$

where $\tilde{f}, \tilde{g} \in C^\infty(M)$ are any smooth functions that coincide with f and g , respectively, on a neighborhood $O \subset U$ of p . To show that this is well-defined it suffices to show that, for any open set $O \subset M$ and any $f, g \in C^\infty(M)$, the bracket $\{f, g\}|_O$ depends only on $f|_O$ and $g|_O$. By skew-symmetry and bilinearity, it suffices to show that $g|_O = 0$ implies $\{f, g\}|_O = 0$. This holds because

$$\{f, g\}|_O = \mathcal{L}_{X_f}(g)|_O = \mathcal{L}_{X_f|_O}(g|_O).$$

Everything else (e.g., Jacobi) follows because it involves identities that can be checked on small enough neighborhoods of points where the functions involved have extensions to the entire M . \square

In a local chart (U, x^1, \dots, x^m) a Poisson bracket $\{\cdot, \cdot\}$ takes the form

$$(1.2) \quad \{f, g\}|_U = \sum_{i,j=1}^m \pi^{ij} \frac{\partial f}{\partial x^i} \frac{\partial g}{\partial x^j},$$

for some smooth functions $\pi^{ij} \in C^\infty(U)$. To see this, decompose the Hamiltonian vector field of $f \in C^\infty(U)$ as

$$X_f = \sum_{j=1}^m X_f^j \frac{\partial}{\partial x^j}.$$

The Leibniz rule gives that the components satisfy

$$X_{f \cdot g}^j = f X_g^j + g X_f^j.$$

Hence, for each j , the map $f \mapsto X_f^j$ is a derivation of $C^\infty(U)$, and we conclude that the Hamiltonian vector field X_f can be written as

$$X_f = \sum_{i,j=1}^m \pi^{ij} \frac{\partial f}{\partial x^i} \frac{\partial}{\partial x^j},$$

which implies (1.2).

The functions π^{ij} are just the Poisson brackets of the local coordinates and are called the **structure functions** of the Poisson bracket with respect to the chart (U, x^1, \dots, x^m) ; i.e.,

$$(1.3) \quad \pi^{ij} = \{x^i, x^j\}_U \in C^\infty(U).$$

They form a skew-symmetric matrix of functions which by (1.2) determine the bracket locally. These functions are not arbitrary.

Exercise 1.3. Consider a skew-symmetric matrix of smooth functions $\pi^{ij} \in C^\infty(U)$, $1 \leq i, j \leq m$, and define an operation $\{\cdot, \cdot\}_U$ on $C^\infty(U)$ by (1.2). Show that the Jacobi identity for $\{\cdot, \cdot\}_U$ is equivalent to the following system of PDEs:

$$(1.4) \quad \sum_{l=1}^m \left(\pi^{il} \frac{\partial \pi^{jk}}{\partial x^l} + \pi^{jl} \frac{\partial \pi^{ki}}{\partial x^l} + \pi^{kl} \frac{\partial \pi^{ij}}{\partial x^l} \right) = 0 \quad (1 \leq i < j < k \leq m).$$

Remark 1.4. The system (1.4) is an *overdetermined nonlinear system of first-order PDEs*: there are $\binom{m}{3}$ -equations on $\binom{m}{2}$ unknown functions π^{ij} . The space of local solutions of this system is poorly understood. This is the first indication that, in contrast with symplectic geometry, Poisson geometry is interesting even locally.

1.2. Orbits

The Hamiltonian vector fields defined by (1.1) give rise to a Lie subalgebra

$$\mathfrak{X}_{\text{Ham}}(M, \{\cdot, \cdot\}) \subset \mathfrak{X}(M).$$

The fact that $\mathfrak{X}_{\text{Ham}}(M, \{\cdot, \cdot\})$ is closed under the Lie bracket of vector fields follows from the Jacobi identity for the Poisson bracket.

Exercise 1.5. Show that the Jacobi identity is equivalent to the assignment $f \mapsto X_f$ being bracket preserving:

$$(1.5) \quad X_{\{f,g\}} = [X_f, X_g], \quad \forall f, g \in C^\infty(M).$$

So for a Poisson bracket this assignment is a Lie algebra homomorphism.

By moving along flows of Hamiltonian vector fields one generates an equivalence relation \sim on M :

$$x \sim y \iff \exists f_1, \dots, f_k \in C^\infty(M) \text{ such that } \phi_{X_{f_1}}^1 \circ \dots \circ \phi_{X_{f_k}}^1(x) = y.$$

The previous exercise shows that the map

$$C^\infty(M) \rightarrow \mathfrak{X}(M), \quad f \mapsto X_f,$$

encodes an infinitesimal action of the Lie algebra $(C^\infty(M), \{\cdot, \cdot\})$ on M (see Section A.2). The definition of \sim is inspired by the definition of the orbits of infinitesimal actions of finite-dimensional Lie algebras (see (A.13)). For this reason, the equivalence classes of \sim will be called the **orbits** of the Poisson manifold $(M, \{\cdot, \cdot\})$.

Remark 1.6. For the time being we use the term **orbit**. Later on we will use the more standard term **symplectic leaf**. As we will see, each orbit is naturally an immersed submanifold of M and has an induced symplectic form.

In general it is not so easy to find the orbits of a given Poisson manifold by directly applying the definition. To get a preliminary idea of what the orbits look like it is very helpful to know the center of the Lie algebra $(C^\infty(M), \{\cdot, \cdot\})$. Its elements deserve a special name:

Definition 1.7. A function $C \in C^\infty(M)$ on a Poisson manifold $(M, \{\cdot, \cdot\})$ is called a **Casimir function** if

$$\{C, f\} = 0, \quad \forall f \in C^\infty(M).$$

Clearly, a Casimir function must be constant on each orbit. So to determine the orbits one can first try to find the Casimir functions, and then their common level sets would form a coarser partition than the orbit partition.

Next, note that the orbit directions are given by the Hamiltonian vector fields:

$$(1.6) \quad \{X_{H,x} : H \in C^\infty(M)\} \subset T_x M,$$

where $X_{H,x} = X_H(x)$ denotes the value of X_H at x . In fact, we shall see that these are indeed the tangent spaces to the orbits. Moreover, for the actual computation of the orbits, we state here the following very useful criterion.

Proposition 1.8. *Assume that \mathcal{S} is a partition of a Poisson manifold $(M, \{\cdot, \cdot\})$ by connected immersed submanifolds such that, for each $S \in \mathcal{S}$,*

$$T_x S = \{X_{H,x} : H \in C^\infty(M)\}, \quad \forall x \in S.$$

Then the members of \mathcal{S} are precisely the orbits of the Poisson manifold.

The proof will be given in Chapter 4.

1.3. Poisson and Hamiltonian diffeomorphisms

A **Poisson diffeomorphism** is a diffeomorphism which is also a Poisson map. The collection of all Poisson diffeomorphisms of $(M, \{\cdot, \cdot\})$ forms a subgroup

$$\text{Diff}(M, \{\cdot, \cdot\}) \subset \text{Diff}(M).$$

Infinitesimal Poisson diffeomorphisms are characterized as follows:

Exercise 1.9. Check that the flow ϕ_V^t of a vector field $V \in \mathfrak{X}(M)$ consists of Poisson diffeomorphisms if and only if

$$(1.7) \quad \mathcal{L}_V(\{f, g\}) = \{\mathcal{L}_V(f), g\} + \{f, \mathcal{L}_V(g)\}, \quad \forall f, g \in C^\infty(M).$$

By a **Poisson vector field** we mean a vector field $V \in \mathfrak{X}(M)$ satisfying (1.7). The following exercise shows that the collection of all Poisson vector fields forms a Lie subalgebra; we denote it by

$$\mathfrak{X}(M, \{\cdot, \cdot\}) \subset \mathfrak{X}(M).$$

Exercise 1.10. Prove the following:

- (a) Every Hamiltonian vector field X_H is a Poisson vector field.
- (b) A vector field V is a Poisson vector field if and only if

$$[V, X_H] = X_{\mathcal{L}_V(H)}, \quad \forall H \in C^\infty(M).$$

- (c) Poisson vector fields form a Lie subalgebra of the Lie algebra of all vector fields.

The exercise shows that the Lie algebra of Hamiltonian vector fields is a Lie ideal of the Lie algebra of Poisson vector fields. Hence, as in symplectic geometry (see Section B.1), we have

$$\mathfrak{X}_{\text{Ham}}(M, \{\cdot, \cdot\}) \subset \mathfrak{X}(M, \{\cdot, \cdot\}) \subset \mathfrak{X}(M).$$

While the Lie algebras $\mathfrak{X}(M)$ and $\mathfrak{X}(M, \{\cdot, \cdot\})$ correspond to the groups $\text{Diff}(M)$ and $\text{Diff}(M, \{\cdot, \cdot\})$, respectively, it is a bit less obvious which group gives rise to the Lie algebra $\mathfrak{X}_{\text{Ham}}(M, \{\cdot, \cdot\})$. In principle this group should arise from flows of Hamiltonian vector fields. However, these are not enough and one needs to consider time-dependent functions.

Definition 1.11. Let $(M, \{\cdot, \cdot\})$ be a Poisson manifold. A **Hamiltonian diffeomorphism** is a diffeomorphism $\phi : M \rightarrow M$ with the following property: there exists a smooth family of diffeomorphisms $\phi^t : M \rightarrow M$, $t \in [0, 1]$, with

$$\phi^0 = \text{id}_M, \quad \phi^1 = \phi,$$

and such that the family is Hamiltonian; i.e., there is a smooth family of functions $\{H_t\}_{t \in [0, 1]}$ on M such that

$$\frac{d}{dt} \phi^t(x) = X_{H_t}(\phi^t(x)), \quad \forall (x, t) \in M \times [0, 1].$$

The collection of all Hamiltonian diffeomorphisms is denoted $\text{Ham}(M, \{\cdot, \cdot\})$ and is called the **Hamiltonian group** of $(M, \{\cdot, \cdot\})$.

A family $\{\phi^t\}_{t \in [0, 1]}$ as in the definition is called a **Hamiltonian isotopy**. Note that ϕ^t is the flow $\Phi_{X_H}^{t, 0}$ of the time-dependent Hamiltonian vector field X_{H_t} (see Section A.3). The fact that $\text{Ham}(M, \{\cdot, \cdot\})$ is indeed a group follows from the exercise below.

Exercise 1.12. Let $\{\phi^t\}_{t \in [0,1]}$ and $\{\psi^t\}_{t \in [0,1]}$ be Hamiltonian isotopies. Show that $\{(\phi^t)^{-1}\}_{t \in [0,1]}$ and $\{\phi^t \circ \psi^t\}_{t \in [0,1]}$ are also Hamiltonian isotopies.

Exercise 1.13. Prove that $\text{Ham}(M, \{\cdot, \cdot\})$ is a normal subgroup of the group of all Poisson diffeomorphisms of $(M, \{\cdot, \cdot\})$.

The proof of the following result is deferred until Chapter 4.

Proposition 1.14. *The orbits of the action of $\text{Ham}(M, \{\cdot, \cdot\})$ on M are precisely the orbits of $(M, \{\cdot, \cdot\})$.*

1.4. Examples

Let us start with some concrete examples. For instance we have a Poisson bracket on \mathbb{R}^2 defined by

$$(1.8) \quad \{x, y\} = 1.$$

The only Casimir functions are the constant ones and there is only one orbit, the entire space \mathbb{R}^2 .

Exercise 1.15. Consider the Poisson bracket on \mathbb{R}^2 defined by

$$\{x, y\} = x^2 + y^2.$$

Is it Poisson diffeomorphic to (1.8)?

Adding the variable z to (1.8) and declaring it to be a Casimir function, we obtain a Poisson bracket on \mathbb{R}^3 :

$$(1.9) \quad \{x, y\} = 1, \quad \{x, z\} = 0, \quad \{y, z\} = 0.$$

Since a Casimir function is constant along leaves, the orbits are contained in the horizontal planes $z = c$. You should deduce using Proposition 1.8 that they actually coincide with these planes. Notice also that if we had considered instead

$$\{x, y\} = 1, \quad \{x, z\} = 0, \quad \{y, z\} = y,$$

then the Jacobi identity would not hold and so this would not be a Poisson bracket.

Next, consider the following *linear* bracket:

$$(1.10) \quad \{x, y\} = z, \quad \{x, z\} = y, \quad \{y, z\} = x.$$

You should check that the Jacobi identity holds. This Poisson bracket has the following Casimir function:

$$C(x, y, z) = x^2 - y^2 + z^2.$$

The origin being a zero of all structure functions, it is fixed by all Hamiltonian flows; therefore it is an orbit. The remaining orbits are the connected

components of the level sets of C in $\mathbb{R}^3 \setminus \{0\}$: the two components of the cone $C = 0$ and the sheets of the hyperboloids $C = r$, for $r \in \mathbb{R}^*$.

Exercise 1.16. Show the following:

- (a) The Poisson brackets (1.9) and (1.10) are not Poisson diffeomorphic.
- (b) Any Poisson automorphism of (1.10) must fix the origin.

Now we consider a *quadratic* Poisson bracket:

$$(1.11) \quad \{x, y\} = xy, \quad \{y, z\} = yz, \quad \{z, x\} = 0.$$

Again, you should verify that the Jacobi identity holds. There is a Casimir function

$$C(x, y, z) = xz,$$

which allows one to determine the orbits. Notice that the structure functions vanish along the plane $y = 0$, so points in this plane are orbits. In particular, this Poisson bracket cannot be Poisson diffeomorphic to the previous Poisson brackets on \mathbb{R}^3 .

We now turn to general classes of examples of Poisson brackets of which the previous brackets will turn out to be special cases.

Example 1.17 (Symplectic structures). Every symplectic manifold (M, ω) has an associated Poisson bracket $\{\cdot, \cdot\}$. It is defined such that the Hamiltonian vector field of $H \in C^\infty(M)$ satisfies

$$i_{X_H}\omega = dH.$$

It follows that the notions of Hamiltonian and symplectic vector field from symplectic geometry (Section B.1) are consistent with the notions of Hamiltonian and Poisson vector field introduced above. As we will see later, besides providing basic examples, symplectic structures are also the building blocks of all Poisson manifolds.

Proposition 1.8 implies that the orbits of a symplectic manifold (M, ω) are the connected components of M .

In particular, we have the **canonical Poisson bracket** on \mathbb{R}^{2s} which is given in linear coordinates $(q^1, \dots, q^s, p_1, \dots, p_s)$ by

$$(1.12) \quad \{f, g\} := \sum_{i=1}^s \left(\frac{\partial f}{\partial p_i} \frac{\partial g}{\partial q^i} - \frac{\partial f}{\partial q^i} \frac{\partial g}{\partial p_i} \right).$$

The structure functions of the canonical Poisson bracket are

$$\{q^i, q^j\} = \{p_i, p_j\} = 0, \quad \{p_i, q^j\} = \delta_i^j.$$

By Darboux's Theorem (Section B.1), any symplectic manifold can be covered by charts in which the Poisson bracket takes this canonical form.

Exercise 1.18. Consider the Poisson bracket on the symplectic manifold $(T^*N, \omega_{\text{can}})$. The evaluation on $X \in \mathfrak{X}(N)$ defines a smooth function

$$\text{ev}_X : T^*N \rightarrow \mathbb{R}, \quad \alpha_x \mapsto \alpha_x(X_x).$$

Show that

$$\text{ev}_{[X,Y]} = \{\text{ev}_X, \text{ev}_Y\}_{\text{can}}, \quad \forall X, Y \in \mathfrak{X}(N).$$

In other words, $\text{ev} : \mathfrak{X}(N) \rightarrow C^\infty(T^*N)$ embeds the Lie algebra of vector fields into the Lie algebra $(C^\infty(T^*N), \{\cdot, \cdot\}_{\text{can}})$.

Exercise 1.19 (Poisson maps versus symplectic maps). Consider two symplectic manifolds (M_1, ω_1) and (M_2, ω_2) and a smooth map $\varphi : M_1 \rightarrow M_2$. Show the following:

- (a) If Φ is a symplectic map, then it must be an immersion. Give examples of symplectic maps between symplectic manifolds of different dimensions.
(HINT: Inclusions.)
- (b) If Φ is a Poisson map, then it must be a submersion. Give examples of Poisson maps between symplectic manifolds of different dimensions.
(HINT: Projections.)
- (c) If Φ is a local diffeomorphism, then φ is a Poisson map if and only if it is a symplectic map.

NOTE: This exercise will become easier at the end of the next chapter. 

Example 1.20 (The zero Poisson bracket). Any manifold M carries the zero Poisson bracket $\{\cdot, \cdot\} \equiv 0$. Notice that its orbits are the points of M ; hence we find ourselves at the opposite spectrum when compared to brackets coming from symplectic manifolds. As we will see later this example often turns out to be more interesting than one might expect at first. For now observe that a Poisson map

$$(1.13) \quad \mu = (\mu_1, \dots, \mu_n) : (M, \{\cdot, \cdot\}) \rightarrow (\mathbb{R}^n, \{\cdot, \cdot\} \equiv 0)$$

is the same thing as a collection of n functions $\mu_i \in C^\infty(M)$ that pairwise Poisson commute:

$$\{\mu_i, \mu_j\} = 0.$$

In particular, when (M, ω) is symplectic and $\{\cdot, \cdot\}$ is the associated Poisson bracket, we recover two classical notions (discussed also in Section B.2):

- (i) A Poisson map μ as in (1.13) is the same thing as the moment map of an **infinitesimal \mathbb{R}^n -Hamiltonian space**.
- (ii) If in addition μ is a submersion almost everywhere and $\dim M = 2n$, then (M, ω, μ) is called a **completely integrable system**. 

Example 1.21 (Constant Poisson brackets). The simplest solutions to the Poisson equation (1.4) are the constant ones: $\pi^{ij}(x) = c^{ij}$. We then talk about a **constant Poisson bracket** on \mathbb{R}^m :

$$(1.14) \quad \{f, g\} = \sum_{i,j=1}^m c^{ij} \frac{\partial f}{\partial x^i} \frac{\partial g}{\partial x^j}, \quad \text{with } c^{ij} \in \mathbb{R}.$$

In this case the orbit equivalence relation \sim is stable under translation. Hence the orbits are all translates of the orbit W through the origin. This orbit is the vector subspace $W \subset \mathbb{R}^m$ spanned by the vectors

$$(1.15) \quad v^i = (c^{i1}, \dots, c^{im}) \in \mathbb{R}^m \quad (1 \leq i \leq m).$$

The condition that $\{\cdot, \cdot\}$ is a constant bracket does not depend on the choice of linear coordinates. It makes sense on any finite-dimensional vector space V and can be characterized more intrinsically as the condition that the bracket of any two linear functions on V is a constant function. 

Example 1.22 (Linear Poisson brackets). A Poisson bracket $\{\cdot, \cdot\}$ on a vector space V with the property that the bracket of linear functions is again linear is called a **linear Poisson bracket**. The importance of these structures is highlighted by the following:

Proposition 1.23. *There is a canonical 1-to-1 correspondence*

$$\left\{ \begin{array}{l} \text{linear Poisson brackets } \{\cdot, \cdot\} \\ \text{on a vector space } V = \mathfrak{g}^* \end{array} \right\} \xleftrightarrow{\sim} \left\{ \begin{array}{l} \text{Lie algebra structures } [\cdot, \cdot] \\ \text{on the dual vector space } \mathfrak{g} = V^* \end{array} \right\}$$

determined by the condition

$$(1.16) \quad \{\text{ev}_u, \text{ev}_v\} = \text{ev}_{[u,v]}, \quad \forall u, v \in \mathfrak{g},$$

where $\text{ev} : \mathfrak{g} \rightarrow C^\infty(\mathfrak{g}^*)$ is the evaluation map that identifies elements of $\mathfrak{g} = V^*$ with linear functions on $\mathfrak{g}^* = V$.

The relation (1.16) says that, given a linear Poisson bracket $\{\cdot, \cdot\}$ on $V = \mathfrak{g}^*$, the corresponding Lie algebra structure $[\cdot, \cdot]$ on \mathfrak{g} is obtained by restricting the Poisson bracket to linear functions. Conversely, given a Lie algebra structure $[\cdot, \cdot]$ on \mathfrak{g} , there is a unique linear Poisson bracket $\{\cdot, \cdot\}$ on $V = \mathfrak{g}^*$ satisfying (1.16). It is given on arbitrary functions $f, g \in C^\infty(\mathfrak{g}^*)$ by

$$(1.17) \quad \{f, g\}(\xi) := \langle [d_\xi f, d_\xi g], \xi \rangle, \quad \forall \xi \in \mathfrak{g}^*,$$

where the differential $d_\xi f : T_\xi \mathfrak{g}^* \rightarrow \mathbb{R}$ is viewed as an element of \mathfrak{g} :

$$\langle d_\xi f, \nu \rangle = \left. \frac{d}{dt} \right|_{t=0} f(\xi + t\nu), \quad \forall \nu \in \mathfrak{g}^*.$$

Exercise 1.24. Prove that (1.17) is indeed a linear Poisson bracket on $V = \mathfrak{g}^*$.

To write the correspondence in the proposition in coordinates, let $\{e^i\}$ be a basis of \mathfrak{g} and denote by (x^i) the induced linear coordinates on $V = \mathfrak{g}^*$. Given a linear Poisson bracket, the resulting structure functions are the linear functions

$$\{x^i, x^j\} = \pi^{ij}(x) = \sum_k c_k^{ij} x^k,$$

where the c_k^{ij} are the structure constants of the Lie algebra \mathfrak{g} w.r.t. the fixed basis:

$$[e^i, e^j] = \sum_k c_k^{ij} e^k.$$

Note that a Poisson bracket on a vector space is linear if and only if its structure functions are linear relative to any linear coordinate system.

Starting with the embedding of Lie algebras from (1.16)

$$\text{ev} : (\mathfrak{g}, [\cdot, \cdot]) \hookrightarrow (C^\infty(\mathfrak{g}^*), \{\cdot, \cdot\})$$

and composing with the map $f \mapsto X_f$, one obtains an infinitesimal \mathfrak{g} -action on the manifold \mathfrak{g}^* :

$$\mathcal{a} : (\mathfrak{g}, [\cdot, \cdot]) \rightarrow (\mathfrak{X}(\mathfrak{g}^*), [\cdot, \cdot]), \quad v \mapsto X_{\text{ev}_v}.$$

This is precisely the coadjoint \mathfrak{g} -action ad^* recalled in Section A.2:

Exercise 1.25. Check that for any $v \in \mathfrak{g}$, one has

$$X_{\text{ev}_v} = \text{ad}_v^*.$$

We now explain that the orbits of the linear Poisson bracket coincide with the coadjoint orbits. These can be described using any connected Lie group G with Lie algebra \mathfrak{g} . Then the infinitesimal \mathfrak{g} -action comes from the coadjoint G -action

$$\text{Ad}^* : G \rightarrow \text{Diff}(\mathfrak{g}^*),$$

whose orbits are the coadjoint orbits. The coadjoint orbit

$$\mathcal{O}_\xi := G \cdot \xi \quad (\xi \in \mathfrak{g}^*)$$

is an immersed submanifold of \mathfrak{g}^* with

$$T_\xi \mathcal{O}_\xi = \{(\text{ad}_v^*)_\xi : v \in \mathfrak{g}\}.$$

For such general facts about smooth actions, see Section A.2. Therefore Exercise 1.25 and Proposition 1.8 imply:

Proposition 1.26. *The orbits of the linear Poisson bracket on \mathfrak{g}^* coincide with the coadjoint orbits.*

Exercise 1.27. Let $\mathfrak{g} = \mathfrak{so}(3, \mathbb{R})$ be the Lie algebra of 3×3 skew-symmetric matrices with bracket the commutator of matrices. Show that if one identifies $\mathfrak{so}(3, \mathbb{R})$ with \mathbb{R}^3 so that the Lie bracket is identified with the vector product \times , then the linear Poisson bracket on $\mathfrak{so}(3, \mathbb{R})^*$ becomes the Poisson bracket on \mathbb{R}^3 given by the triple product:

$$(1.18) \quad \{f, g\}(\mathbf{x}) = (\nabla f(\mathbf{x}) \times \nabla g(\mathbf{x})) \cdot \mathbf{x} = \begin{vmatrix} \frac{\partial f}{\partial x} & \frac{\partial f}{\partial y} & \frac{\partial f}{\partial z} \\ \frac{\partial g}{\partial x} & \frac{\partial g}{\partial y} & \frac{\partial g}{\partial z} \\ x & y & z \end{vmatrix}.$$

Moreover, show the following:

- (a) The equations for the orbits of the Hamiltonian vector field corresponding to the function $H(x, y, z) = \frac{x^2}{2I_x} + \frac{y^2}{2I_y} + \frac{z^2}{2I_z}$ are

$$(1.19) \quad \begin{cases} \dot{x} = \{H, x\} = \frac{I_y - I_z}{I_y I_z} yz, \\ \dot{y} = \{H, y\} = \frac{I_z - I_x}{I_z I_x} zx, \\ \dot{z} = \{H, z\} = \frac{I_x - I_y}{I_x I_y} yx. \end{cases}$$

These are the Euler equations describing the motion of a top in the absence of gravity, moving around its center of mass, with moments of inertia I_x , I_y , and I_z (see, e.g., [13] for such examples).

- (b) The orbits of this Poisson bracket are the spheres centered at the origin, and the origin.
- (c) The Poisson bracket is not Poisson diffeomorphic to (1.10). 

Example 1.28 (Quadratic Poisson brackets). Moving one degree higher, a **quadratic Poisson bracket** on a vector space is one for which the Poisson bracket of any two linear functions is a homogeneous polynomial of degree 2.

A relatively simple family of such brackets on \mathbb{R}^m can be constructed as follows. Fix an $m \times m$ skew-symmetric matrix $A = (a^{ij})$ and define

$$(1.20) \quad \{f, g\}_A := \sum_{i,j=1}^m a^{ij} x^i x^j \frac{\partial f}{\partial x^i} \frac{\partial g}{\partial x^j}.$$

You should convince yourself that the Jacobi identity holds.

Exercise 1.29. There are even more general quadratic Poisson brackets than the Poisson brackets (1.20). Give such examples in \mathbb{R}^2 and \mathbb{R}^3 .

Let us restrict the Poisson bracket $\{\cdot, \cdot\}_A$ to the open subset

$$\mathbb{R}_{>0}^m := \{(x^1, \dots, x^m) : x^i > 0, i = 1, \dots, m\}.$$

Fix $\lambda_1, \dots, \lambda_m \in \mathbb{R}$ and define the following function on $\mathbb{R}_{>0}^m$:

$$H := \sum_{i=1}^m (\lambda_i \log x^i - x^i).$$

The flow of the Hamiltonian vector field X_H is the solution to the system of ODEs

$$(1.21) \quad \dot{x}^i = \{H, x^i\} = \varepsilon_i x^i + \sum_{j=1}^m a^{ij} x^i x^j \quad (1 \leq i \leq m),$$

where we have introduced the constants $\varepsilon_i := \sum_{j=1}^m a^{ji} \lambda_j$. Equations (1.21) are the famous Lotka-Volterra equations which model the dynamics of the populations of n biological species interacting in an ecosystem [91]. For this reason we shall call (1.20) the **LV-type Poisson bracket** associated with the skew-symmetric matrix A .

Exercise 1.30. Find the orbits of the LV-type Poisson bracket on \mathbb{R}^3 with structure functions:

$$(1.22) \quad \{x, y\} = xy, \quad \{y, z\} = yz, \quad \{z, x\} = zx.$$

(HINT: Find a Casimir function.)

Exercise 1.31. Consider the map $\Phi: \mathbb{R}^{2m} \rightarrow \mathbb{R}^m$, $(q^i, p_i) \mapsto x^i$, defined by

$$(1.23) \quad x^i = e^{p_i - \frac{1}{2} \sum_{j=1}^m a^{ij} q^j}.$$

Show that Φ is a Poisson map when we equip \mathbb{R}^{2m} with the canonical Poisson bracket (1.12) and \mathbb{R}^m with the LV-type Poisson bracket (1.20). 

1.5. Poisson actions and quotients

There are natural ways of producing new Poisson manifolds out of known Poisson manifolds. For example, one can form products of Poisson manifolds (see Problem 1.2). Another way is by forming quotients as we now discuss.

Given a proper and free **symplectic action** of a Lie group G on a symplectic manifold (M, ω) , the quotient M/G has an induced Poisson bracket, which is uniquely determined by the property that the quotient map

$$p: M \rightarrow M/G$$

is a Poisson map. This follows because $C^\infty(M/G) = C^\infty(M)^G$ is closed under the Poisson bracket on M (see Exercise B.11). Even though we start with a symplectic manifold, the resulting Poisson bracket can have intricate geometry. Here is an explicit example.

Example 1.32. Start with the symplectic manifold:

$$M = \mathbb{C}^2 \setminus \{0\}, \quad \omega = \frac{1}{2}(dz \wedge d\bar{w} + d\bar{z} \wedge dw),$$

which admits the free and proper symplectic $G = \mathbb{S}^1$ -action given by

$$\theta \cdot (z, w) = (e^{i\theta}z, e^{i\theta}w).$$

Consider the \mathbb{S}^1 -invariant functions on M :

$$\sigma_1 = \frac{1}{2}(|z|^2 + |w|^2), \quad \sigma_2 = \frac{1}{2}(|z|^2 - |w|^2), \quad \sigma_3 = z\bar{w} + \bar{z}w.$$

The Poisson brackets of these functions are given by

$$\{\sigma_1, \sigma_2\} = \sigma_3, \quad \{\sigma_2, \sigma_3\} = -\sigma_1, \quad \{\sigma_1, \sigma_3\} = \sigma_2.$$

They induce a smooth map:

$$\sigma : M/\mathbb{S}^1 \rightarrow \mathbb{R}^3, \quad [x] \mapsto (\sigma_1(x), \sigma_2(x), \sigma_3(x)).$$

The restriction of σ to an open dense set $U \subset M/\mathbb{S}^1$ is an embedding. So (U, σ) is a chart on the quotient in which the Poisson bracket is linear. 

In general, the orbits of the Poisson manifold M/G may be hard to determine. However, in the case of Hamiltonian G -spaces the situation improves. Recall — see Section B.2 — that such a Hamiltonian G -space consists of a symplectic G -space (M, ω) together with a G -equivariant map $\mu : M \rightarrow \mathfrak{g}^*$ satisfying the moment map condition:

$$i_{\mathfrak{a}(v)}\omega = d\mu_v, \quad \forall v \in \mathfrak{g},$$

where $\mathfrak{a} : \mathfrak{g} \rightarrow \mathfrak{X}(M)$ denotes the infinitesimal \mathfrak{g} -action. We then have the following result relating the orbits and the symplectic quotients:

Proposition 1.33. *Let (M, ω) be a Hamiltonian G -space with moment map $\mu : M \rightarrow \mathfrak{g}^*$, and assume that the action is free and proper. Then the orbits of the Poisson manifold M/G are the connected components of the symplectic quotients $M//_{\mathcal{O}}G := \mu^{-1}(\mathcal{O})/G \subset M/G$, where \mathcal{O} ranges through the coadjoint orbits of \mathfrak{g}^* .*

Proof. The connected components of the symplectic quotients $M//_{\mathcal{O}}G$, when \mathcal{O} ranges through the coadjoint orbits of \mathfrak{g}^* , give a partition of M/G by connected immersed submanifolds. According to Proposition 1.8, all we have to check is that

$$T_y(M//_{\mathcal{O}}G) = \{X_{H,y} : H \in C^\infty(M/G)\}, \quad \forall y \in M//_{\mathcal{O}}G.$$

To see this we first observe that, since $p : M \rightarrow M/G$ is a Poisson map, if $H \in C^\infty(M/G)$, then the vector fields $X_H \in \mathfrak{X}(M/G)$ and $X_{H \circ p} \in \mathfrak{X}(M)$ satisfy

$$X_{H \circ p}(f \circ p) = X_H(f) \circ p, \quad \forall f \in C^\infty(M/G).$$

In other words,

$$dp(X_{H \circ p, x}) = X_{H, p(x)}, \quad \forall x \in M.$$

Note that for each $\xi \in \mathcal{O}$ the projection restricts to a submersion $p : \mu^{-1}(\xi) \rightarrow M //_{\mathcal{O}} G$, which induces the isomorphism:

$$M //_{\xi} G := \mu^{-1}(\xi) / G_{\xi} \simeq M //_{\mathcal{O}} G.$$

We claim that

$$(1.24) \quad T_x \mu^{-1}(\xi) = \{X_{H \circ p, x} : H \in C^{\infty}(M/G)\},$$

so the result will follow.

We now observe that any Hamiltonian vector field $X_{H \circ p}$ is symplectic orthogonal to the G -orbits. Indeed, since the image of the infinitesimal action $\mathfrak{a} : \mathfrak{g} \rightarrow \mathfrak{X}(M)$ at x — see Section B.2 — coincides with the tangent space to the orbit through x , it is enough to observe that

$$\omega(\mathfrak{a}(v), X_{H \circ p}) = -\mathfrak{a}(v)(H \circ p) = 0, \quad \forall v \in \mathfrak{g}.$$

Now, (1.24) will follow from the following lemma:

Lemma 1.34. *For any Hamiltonian G -space, the orbits of the action are symplectic orthogonal to the fibers of the moment map. More precisely,*

$$T(G \cdot x)^{\perp \omega} = \text{Ker } d\mu, \quad \forall x \in M.$$

Proof of the lemma. The image of \mathfrak{a} coincides with the tangent space to the orbits. The lemma follows by observing that the moment map condition

$$i_{\mathfrak{a}(v)} \omega = d\mu_v$$

implies that $\omega(\mathfrak{a}(v), w) = 0$, whenever $v \in \mathfrak{g}$ and $w \in \text{Ker } d_y \mu$, and that $T_y(G \cdot x)$ and $\text{Ker } d_y \mu$ have complementary dimension. \square

The inclusion \supset in our claim (1.24) is now obvious. For the other inclusion, we need to prove that any tangent vector $X \in T_x \mu^{-1}(\xi)$ can be written as

$$X = X_{H \circ p, x},$$

for some $H \in C^{\infty}(M/G)$. Setting $\alpha = i_X \omega$, the lemma implies that α annihilates the tangent space to the orbits and hence is the pullback of a covector in M/G . Since any covector can be realized as the differential of a function, we can write

$$\alpha = p^* d_x H,$$

for some function $H \in C^{\infty}(M/G)$. Then $X = X_{H \circ p, x}$, as required. \square

Example 1.35 (Moment maps as Poisson maps). Symplectic manifolds and linear Poisson brackets on duals of Lie algebras interact nicely within the Hamiltonian framework. We need here the infinitesimal version of this framework. A **\mathfrak{g} -Hamiltonian space** consists of a symplectic manifold (M, ω) , an infinitesimal Lie algebra action $\mathfrak{a} : \mathfrak{g} \rightarrow \mathfrak{X}(M)$, and a smooth map $\mu : M \rightarrow \mathfrak{g}^*$ satisfying the following:

- (i) ω is \mathfrak{g} -invariant.
- (ii) μ is \mathfrak{g} -equivariant.
- (iii) The moment map condition: $i_{\mathfrak{a}(v)}\omega = d\mu_v, \forall v \in \mathfrak{g}$.

Note that the moment map condition (iii) implies that the map $\mathfrak{a} : \mathfrak{g} \rightarrow \mathfrak{X}(M)$ can be recovered from μ and ω . It is remarkable that all the other conditions can be packed into one single property, namely that the map

$$\mathfrak{g} \rightarrow C^\infty(M), \quad v \mapsto \mu_v$$

is a Lie algebra homomorphism — as discussed in Section B.2 — or, equivalently, that μ is a Poisson map! In other words, given (M, ω) and \mathfrak{g} there is a 1-to-1 correspondence

$$\left\{ \begin{array}{l} \text{Poisson maps} \\ \mu : (M, \omega) \rightarrow (\mathfrak{g}^*, \pi_{\mathfrak{g}}) \end{array} \right\} \xleftrightarrow{\sim} \left\{ \begin{array}{l} \mathfrak{g}\text{-Hamiltonian} \\ \text{spaces } (M, \omega) \end{array} \right\}. \quad \img alt="fish icon" data-bbox="825 500 859 515"/>$$

Most of this discussion generalizes to Poisson manifolds. A **Poisson action** of a Lie group G on a Poisson manifold $(M, \{\cdot, \cdot\})$ is an action $\mathcal{A} : G \rightarrow \text{Diff}(M)$ with the property that the translation by any $g \in G$ is a Poisson map:

$$\mathcal{A}_g : (M, \{\cdot, \cdot\}) \rightarrow (M, \{\cdot, \cdot\}), \quad x \mapsto g \cdot x.$$

The quotient construction immediately extends to the Poisson setting:

Proposition 1.36. *Given a free and proper Poisson action of a Lie group G on a Poisson manifold $(M, \{\cdot, \cdot\})$, the orbit space M/G has a unique Poisson bracket for which the projection $p : M \rightarrow M/G$ is a Poisson map.*

Example 1.37. There are many possible concrete illustrations of this construction. For example, one can construct interesting Poisson brackets on the real projective space $\mathbb{R}P^{n-1}$ by starting with an LV-type quadratic Poisson bracket $\{\cdot, \cdot\}_A$ on $\mathbb{R}^n \setminus \{0\}$ from Example 1.28 and the \mathbb{R}^* -action $(\lambda, x) \mapsto \lambda x$. The outcome can be quite interesting:

Exercise 1.38. Consider the quotient Poisson bracket on the projective plane $\mathbb{R}P^2$ induced by the LV-type Poisson bracket on $\mathbb{R}^3 \setminus \{0\}$ from Exercise

1.30. Show that the 0-dimensional orbits are the points on the three circles:

$$Z = \{[x : y : 0]\} \cup \{[x : 0 : z]\} \cup \{[0 : y : z]\},$$

and that 2-dimensional orbits are the four components of $\mathbb{RP}^2 \setminus Z$. 

One can also generalize Hamiltonian actions to Poisson manifolds. We say that a Poisson action of a Lie group G on $(M, \{\cdot, \cdot\})$ is a **Hamiltonian action** if there is a G -equivariant map $\mu : M \rightarrow \mathfrak{g}^*$ such that the infinitesimal action $\mathfrak{a} : \mathfrak{g} \rightarrow \mathfrak{X}(M)$ satisfies the **moment map condition**:

$$(1.25) \quad \mathfrak{a}(v) = X_{\mu_v}, \quad \forall v \in \mathfrak{g}.$$

Exercise 1.39. For a connected Lie group G , show that the G -orbits of a Hamiltonian G -space $(M, \{\cdot, \cdot\}, \mu)$ are always contained in the orbits of the Poisson manifold M . Is this still true for a Poisson action? (HINT: Look at the Poisson action of Example 1.37.)

As for the analogue of Proposition 1.33, consider a proper and free Hamiltonian G -space $(M, \{\cdot, \cdot\})$ with moment map $\mu : M \rightarrow \mathfrak{g}^*$ and fix a coadjoint orbit $\mathcal{O} \subset \mathfrak{g}^*$. In this case, the statement becomes that the quotient

$$M //_{\mathcal{O}} G := \mu^{-1}(\mathcal{O})/G$$

carries a unique Poisson bracket such that the inclusion $M //_{\mathcal{O}} G \hookrightarrow M/G$ is a Poisson map. This will be discussed in detail in Section 8.1. For now we look at an example.

Example 1.40. Consider the linear Poisson bracket on $\mathfrak{so}^*(3, \mathbb{R}) \simeq \mathbb{R}^3$ as in Exercise 1.27. In coordinates (x, y, z) it is given by

$$\{x, y\} = z, \quad \{y, z\} = x, \quad \{z, x\} = y.$$

The action of \mathbb{S}^1 on \mathbb{R}^3 by rotations around the z -axis Oz is Hamiltonian with moment map

$$\mu : \mathbb{R}^3 \rightarrow \mathbb{R}, \quad \mu(x, y, z) = z.$$

The restriction of this action to the open set $M = \mathbb{R}^3 \setminus Oz$ is a proper and free Hamiltonian action. The induced Poisson bracket on the quotient M/\mathbb{S}^1 is zero: the \mathbb{S}^1 -invariant functions $u = x^2 + y^2$ and $v = z$ give global coordinates on the quotient and we have

$$\{u, v\}_{M/\mathbb{S}^1} = \{x^2 + y^2, z\} = 0.$$

Now, recalling that $\mathfrak{so}(4, \mathbb{R}) \simeq \mathfrak{so}(3, \mathbb{R}) \oplus \mathfrak{so}(3, \mathbb{R})$, the linear Poisson bracket on $\mathfrak{so}(4, \mathbb{R})^* \simeq \mathbb{R}^3 \times \mathbb{R}^3$ is given in coordinates $(x_1, y_1, z_1, x_2, y_2, z_2)$ by

$$\{x_i, y_i\} = z_i, \quad \{y_i, z_i\} = x_i, \quad \{z_i, x_i\} = y_i,$$

where the other structure functions are zero. We use the diagonal S^1 -action on $\mathbb{R}^3 \times \mathbb{R}^3$. This is still Hamiltonian with moment map:

$$\mu : \mathbb{R}^3 \times \mathbb{R}^3 \rightarrow \mathbb{R}, \quad \mu(x_1, y_1, z_1, x_2, y_2, z_2) = z_1 + z_2.$$

The action is proper and free on the open set $M = (\mathbb{R}^3 \setminus Oz) \times \mathbb{R}^3$. We leave as an exercise to determine the quotient Poisson bracket on M/S^1 (it is nonzero!).

Problems

1.1. Recall that a first integral of a vector field $V \in \mathfrak{X}(M)$ is any function $f \in C^\infty(M)$ which is constant on the integral curves of V . Given a Poisson manifold $(M, \{\cdot, \cdot\})$ and a function $H \in C^\infty(M)$, show that if f and g are first integrals of X_H , then $\{f, g\}$ is a first integral of X_H .

1.2. Let $(M_1, \{\cdot, \cdot\}_1)$ and $(M_2, \{\cdot, \cdot\}_2)$ be Poisson manifolds. Show that on the product $M_1 \times M_2$ the following formula defines a Poisson bracket:

$$\{f, g\}(x_1, x_2) := \{f(\cdot, x_2), g(\cdot, x_2)\}_1(x_1) + \{f(x_1, \cdot), g(x_1, \cdot)\}_2(x_2).$$

Show that this is the unique Poisson bracket on the product for which the projections $p_i : M_1 \times M_2 \rightarrow M_i$ are Poisson maps and

$$\{p_1^*(f), p_2^*(g)\} = 0, \quad \forall f \in C^\infty(M_1), g \in C^\infty(M_2).$$

1.3. Consider on $G = \mathbb{R}_+ \times \mathbb{R}$ the Poisson bracket of LV-type:

$$\{x, y\} = xy.$$

Consider also the group operation $m : G \times G \rightarrow G$:

$$m((x_1, y_1), (x_2, y_2)) := (x_1 x_2, y_1 + x_1 y_2).$$

Show that $m : G \times G \rightarrow G$ is a Poisson map, where we use the product Poisson structure on the domain.

NOTE: A pair $(G, \{\cdot, \cdot\}_G)$ where G is a Lie group and $\{\cdot, \cdot\}_G$ is a Poisson bracket for which multiplication $m : (G \times G, \{\cdot, \cdot\}_{G \times G}) \rightarrow (G, \{\cdot, \cdot\}_G)$ is called a **Poisson-Lie group**.

1.4. In the standard coordinates $(z_0 = x_0 + iy_0, z_1 = x_1 + iy_1, \dots, z_n = x_n + iy_n)$ on \mathbb{C}^{n+1} , consider the bracket defined by

$$(1.26) \quad \{f, g\} := i \sum_{j=0}^n z_j \bar{z}_j \left(\frac{\partial f}{\partial z_j} \frac{\partial g}{\partial \bar{z}_j} - \frac{\partial g}{\partial z_j} \frac{\partial f}{\partial \bar{z}_j} \right).$$

(a) Verify that this formula defines a (real) Poisson bracket on \mathbb{C}^{n+1} .

- (b) Show that the action of \mathbb{C}^* on $\mathbb{C}^{n+1} \setminus \{0\}$ is by Poisson diffeomorphism and hence there is a quotient Poisson bracket on $\mathbb{C}\mathbb{P}^n$.
- (c) Determine the Hamiltonian vector field X_{H_j} on $\mathbb{C}\mathbb{P}^n$ of the function

$$H_j([z_0 : \cdots : z_n]) = \frac{|z_j|^2}{|z_0|^2 + \cdots + |z_n|^2}.$$

1.5. Show that for any quadratic Poisson bracket on \mathbb{R}^n the Euler vector field

$$E = \sum_{i=1}^n x^i \frac{\partial}{\partial x^i}$$

is a Poisson vector field which is not Hamiltonian.

1.6. Show that on a 2-dimensional manifold M any skew-symmetric, bilinear bracket $\{\cdot, \cdot\}$ on $C^\infty(M)$ satisfying the Leibniz identity also satisfies the Jacobi identity.

1.7. Let $\mathcal{A} : G \times M \rightarrow M$ be an action of a Lie group G on a manifold M and denote by $\mathfrak{a} : \mathfrak{g} \rightarrow \mathfrak{X}(M)$ the corresponding infinitesimal action. If $(M, \{\cdot, \cdot\})$ is a Poisson manifold and the G -action is by Poisson diffeomorphisms, verify that $\mathfrak{a}(v)$ is a Poisson vector field, for all $v \in \mathfrak{g}$. Show that the converse holds provided G is a connected Lie group.

1.8. Let $C : M \rightarrow \mathbb{R}$ be a Casimir function of a Poisson manifold $(M, \{\cdot, \cdot\})$. If 0 is a regular value of C , show that $C^{-1}(0)$ has a unique Poisson bracket for which the inclusion $i : C^{-1}(0) \hookrightarrow M$ is a Poisson map.

1.9. Let G be a Lie group with Lie algebra \mathfrak{g} . Consider the linear Poisson bracket on \mathfrak{g}^* . Show that the coadjoint action $G \times \mathfrak{g}^* \rightarrow \mathfrak{g}^*$ is Hamiltonian with moment map $\mu = \text{Id}_{\mathfrak{g}^*} : \mathfrak{g}^* \rightarrow \mathfrak{g}^*$.

1.10. Identify the Lie algebra $\mathfrak{g} = \mathfrak{sl}(2, \mathbb{R})$ with $(\mathbb{R}^3)^*$ by identifying a traceless 2×2 real matrix

$$\begin{pmatrix} a & b - c \\ b + c & -a \end{pmatrix}$$

with the linear functional $(x, y, z) \mapsto ax + by + cz$.

- (a) Show that under this identification the Poisson bracket on $\mathfrak{sl}(2, \mathbb{R})^*$ becomes the following Poisson bracket on \mathbb{R}^3 :

$$(1.27) \quad \{f, g\}(\mathbf{x}) = \begin{vmatrix} \frac{\partial f}{\partial x} & \frac{\partial f}{\partial y} & \frac{\partial f}{\partial z} \\ \frac{\partial g}{\partial x} & \frac{\partial g}{\partial y} & \frac{\partial g}{\partial z} \\ 2x & 2y & -2z \end{vmatrix}.$$

- (b) Verify that $C(x, y, z) = x^2 + y^2 - z^2$ is a Casimir function for this Poisson bracket.

- (c) Find the orbits of this Poisson bracket.
(d) Show that this Poisson structure is Poisson diffeomorphic to (1.10).

1.11. Let G be a Lie group and consider the symplectic manifold $(T^*G, \omega_{\text{can}})$. Let G act on itself (on the left) by right translations:

$$\mathcal{A} : G \times G \rightarrow G, \quad \mathcal{A}_g(h) \mapsto hg^{-1},$$

and consider the lifted symplectic action $G \times T^*G \rightarrow T^*G$. Show that the resulting Poisson quotient T^*G/G is isomorphic to \mathfrak{g}^* with the linear Poisson bracket.

Poisson Bivectors

2.1. The point of view of bivectors

The local expression (1.2) for the Poisson bracket suggests that the Poisson bracket is encoded by an expression of the form

$$\pi = \sum_{i < j} \pi^{ij} \frac{\partial}{\partial x^i} \wedge \frac{\partial}{\partial x^j}.$$

Note that the skew-symmetry is already taken into account through the use of wedge products. Such an expression is an example of a **bivector field** on M , i.e., a section of $\bigwedge^2 TM$. The Jacobi identity amounts to some extra condition on π expressed by the Poisson equation (1.4).

We shall now discuss the calculus of **multivector fields** (also called *polyvector fields*). Recall that a differential form of degree k

$$\omega \in \Omega^k(M) := \Gamma\left(\bigwedge^k T^*M\right)$$

can be identified with a $C^\infty(M)$ -multilinear, alternating map of degree k on the space $\mathfrak{X}^1(M) := \mathfrak{X}(M)$ of vector fields on M :

$$\omega : \underbrace{\mathfrak{X}^1(M) \times \cdots \times \mathfrak{X}^1(M)}_{k\text{-times}} \rightarrow C^\infty(M).$$

Dually, a smooth **multivector field** of degree k on M

$$\vartheta \in \mathfrak{X}^k(M) := \Gamma\left(\bigwedge^k TM\right)$$

can be identified with a $C^\infty(M)$ -multilinear, alternating map of degree k on the space $\Omega^1(M)$ of 1-forms on M :

$$(2.1) \quad \vartheta : \underbrace{\Omega^1(M) \times \cdots \times \Omega^1(M)}_{k\text{-times}} \rightarrow C^\infty(M).$$

Under this identification the resulting wedge product

$$\cdot \wedge \cdot : \mathfrak{X}^k(M) \times \mathfrak{X}^l(M) \rightarrow \mathfrak{X}^{k+l}(M)$$

can be described explicitly by the usual formula

$$(\vartheta \wedge \zeta)(\alpha_1, \dots, \alpha_{k+l}) = \sum_{\sigma \in S_{k,l}} (-1)^\sigma \vartheta(\alpha_{\sigma(1)}, \dots, \alpha_{\sigma(k)}) \zeta(\alpha_{\sigma(k+1)}, \dots, \alpha_{\sigma(k+l)}),$$

where the sum is over all (k, l) -shuffles. In degree $k = 0$, we have $\mathfrak{X}^0(M) = C^\infty(M)$ and $f \wedge \vartheta = f \cdot \vartheta$. As for forms, this operation is graded commutative and associative:

$$\vartheta \wedge \zeta = (-1)^{\deg \vartheta \deg \zeta} \zeta \wedge \vartheta, \quad (\vartheta \wedge \zeta) \wedge \tau = \vartheta \wedge (\zeta \wedge \tau);$$

i.e., one obtains a graded commutative algebra structure on

$$\mathfrak{X}^\bullet(M) = \bigoplus_{k=0}^m \mathfrak{X}^k(M).$$

If (U, x^1, \dots, x^m) are local coordinates on M , then the coordinate vector fields $\{\frac{\partial}{\partial x^1}, \dots, \frac{\partial}{\partial x^m}\}$ form a basis for the $C^\infty(U)$ -module $\mathfrak{X}(U)$. Taking wedge products we obtain a basis for the $C^\infty(U)$ -module $\mathfrak{X}^k(U)$:

$$\frac{\partial}{\partial x^{i_1}} \wedge \cdots \wedge \frac{\partial}{\partial x^{i_k}}, \quad i_1 < i_2 < \cdots < i_k.$$

In particular, we find the local representation of a k -vector field $\vartheta \in \mathfrak{X}^k(M)$:

$$\vartheta|_U = \sum_{i_1 < \cdots < i_k} \vartheta^{i_1 \dots i_k}(x) \frac{\partial}{\partial x^{i_1}} \wedge \cdots \wedge \frac{\partial}{\partial x^{i_k}},$$

for uniquely determined smooth functions $\vartheta^{i_1 \dots i_k} \in C^\infty(U)$. In the case of a bivector field π we obtain

$$\pi|_U = \sum_{i < j} \pi^{ij}(x) \frac{\partial}{\partial x^i} \wedge \frac{\partial}{\partial x^j}.$$

In the same way that a vector field $X \in \mathfrak{X}(M) = \mathfrak{X}^1(M)$ can be identified with a derivation $\mathcal{L}_X : C^\infty(M) \rightarrow C^\infty(M)$ on the algebra of smooth functions, a multivector field $\vartheta \in \mathfrak{X}^k(M)$ can be identified with a similar operation

$$(2.2) \quad \begin{aligned} \mathcal{L}_\vartheta : C^\infty(M) \times \cdots \times C^\infty(M) &\rightarrow C^\infty(M), \\ \mathcal{L}_\vartheta(f_1, \dots, f_k) &:= \vartheta(df_1, \dots, df_k). \end{aligned}$$

This operation is alternating and a multiderivation, meaning that it is a derivation with respect to each argument:

$$\mathcal{L}_\vartheta(f_1, \dots, gh, \dots, f_k) = \mathcal{L}_\vartheta(f_1, \dots, g, \dots, f_k)h + g\mathcal{L}_\vartheta(f_1, \dots, h, \dots, f_k).$$

Proposition 2.1. *On any manifold M , $\vartheta \mapsto \mathcal{L}_\vartheta$ gives a 1-to-1 correspondence*

$$\left\{ \begin{array}{l} \text{multivector fields} \\ \vartheta \in \mathfrak{X}^k(M) \end{array} \right\} \xleftrightarrow{\sim} \left\{ \mathcal{L} : \underbrace{C^\infty(M) \times \dots \times C^\infty(M)}_{k\text{-times}} \rightarrow C^\infty(M) \right\}.$$

Exercise 2.2. Prove Proposition 2.1.

(HINT: The proof is entirely similar to the case of vector fields.)

For us the degree 2 case of **biderivations** plays a special role: these are maps

$$\{\cdot, \cdot\} : C^\infty(M) \times C^\infty(M) \rightarrow C^\infty(M)$$

which are \mathbb{R} -bilinear and skew-symmetric and satisfy the Leibniz identity — thus all the properties of Poisson brackets hold, except for the Jacobi identity. According to the proposition, a 2-derivation $\{\cdot, \cdot\}$ corresponds to a bivector field $\pi \in \mathfrak{X}^2(M)$ via

$$(2.3) \quad \pi(df, dg) = \{f, g\}.$$

In order to rewrite the Jacobi identity one needs to generalize the usual Lie bracket on vector fields. This can be defined by

$$\mathcal{L}_{[X, Y]} = \mathcal{L}_X \circ \mathcal{L}_Y - \mathcal{L}_Y \circ \mathcal{L}_X,$$

and for arbitrary multivector fields we introduce:

Definition 2.3. The **Schouten bracket** of the multivector fields $\vartheta \in \mathfrak{X}^{k+1}(M)$ and $\zeta \in \mathfrak{X}^{l+1}(M)$ is the unique multivector field $[\vartheta, \zeta] \in \mathfrak{X}^{k+l+1}(M)$ satisfying

$$(2.4) \quad \mathcal{L}_{[\vartheta, \zeta]} = \mathcal{L}_\vartheta \circ \mathcal{L}_\zeta - (-1)^{kl} \mathcal{L}_\zeta \circ \mathcal{L}_\vartheta,$$

where

$$\begin{aligned} &\mathcal{L}_\vartheta \circ \mathcal{L}_\zeta(f_1, \dots, f_{k+l+1}) \\ &:= \sum_{\sigma \in S_{k, l+1}} (-1)^\sigma \mathcal{L}_\vartheta(f_{\sigma(1)}, \dots, f_{\sigma(k)}, \mathcal{L}_\zeta(f_{\sigma(k+1)}, \dots, f_{\sigma(k+l+1)})), \end{aligned}$$

and the sum is over all $(k, l + 1)$ -shuffles.

Remark 2.4. By convention, for $f \in C^\infty(M)$ we set $\mathcal{L}_f = f$ and $\mathcal{L}_f \circ \mathcal{L}_\vartheta = 0$. Note that with this convention, for $\vartheta \in \mathfrak{X}^{k+1}(M)$ one has

$$\mathcal{L}_{[\vartheta, f]} = \mathcal{L}_\vartheta \circ \mathcal{L}_f = (-1)^k i_{df} \vartheta.$$

Exercise 2.5. Just as for vector fields, while $\mathcal{L}_\vartheta \circ \mathcal{L}_\zeta$ is not a multiderivation, check that the graded commutator (2.4) is (therefore, Definition 2.3 is correct).

For a biderivation $\{\cdot, \cdot\} : C^\infty(M) \times C^\infty(M) \rightarrow C^\infty(M)$ with associated bivector field $\pi \in \mathfrak{X}^2(M)$ we find that

$$(2.5) \quad \frac{1}{2} \mathcal{L}_{[\pi, \pi]}(f, g, h) = \{f, \{g, h\}\} + \{g, \{h, f\}\} + \{h, \{f, g\}\}.$$

Therefore, we obtain one of the main conclusions of this section:

Corollary 2.6. *On any manifold M , (2.3) induces a 1-to-1 correspondence*

$$\left\{ \begin{array}{l} \text{Poisson brackets} \\ \{\cdot, \cdot\} \text{ on } M \end{array} \right\} \xleftrightarrow{\sim} \left\{ \begin{array}{l} \text{bivector fields } \pi \in \mathfrak{X}^2(M) \\ \text{satisfying } [\pi, \pi] = 0 \end{array} \right\}.$$

Definition 2.7. A bivector field $\pi \in \mathfrak{X}^2(M)$ satisfying $[\pi, \pi] = 0$ is called a **Poisson structure** or a **Poisson bivector** on M . We also say that the pair (M, π) is a **Poisson manifold**.

While the previous definition of the Schouten bracket has the advantage of being explicit, it may not be so enlightening. A more conceptual approach is the following:

Theorem 2.8. *The Schouten bracket is the unique \mathbb{R} -bilinear operation*

$$[\cdot, \cdot] : \mathfrak{X}^{k+1}(M) \times \mathfrak{X}^{l+1}(M) \rightarrow \mathfrak{X}^{k+l+1}(M), \quad (k, l \geq -1)$$

satisfying the following properties:

- (i) *When $k = l = 0$ it is the usual Lie bracket of vector fields.*
- (ii) *When $k = 0$ and $l = -1$ it is the Lie derivative:*

$$[X, f] = \mathcal{L}_X f = X(f).$$

- (iii) *Graded skew-symmetry:*

$$[\vartheta, \zeta] = -(-1)^{kl}[\zeta, \vartheta],$$

for $\vartheta \in \mathfrak{X}^{k+1}(M)$ and $\zeta \in \mathfrak{X}^{l+1}(M)$.

- (iv) *Graded Leibniz identity:*

$$[\vartheta, \zeta \wedge \tau] = [\vartheta, \zeta] \wedge \tau + (-1)^{k(l+1)} \zeta \wedge [\vartheta, \tau],$$

for $\vartheta \in \mathfrak{X}^{k+1}(M)$, $\zeta \in \mathfrak{X}^{l+1}(M)$, and $\tau \in \mathfrak{X}^{m+1}(M)$.

Moreover, the graded Jacobi identity holds:

$$(-1)^{km}[\vartheta, [\zeta, \tau]] + (-1)^{lk}[\zeta, [\tau, \vartheta]] + (-1)^{lm}[\tau, [\vartheta, \zeta]] = 0,$$

for $\vartheta \in \mathfrak{X}^{k+1}(M)$, $\zeta \in \mathfrak{X}^{l+1}(M)$, and $\tau \in \mathfrak{X}^{m+1}(M)$.

Proof. We leave it as an exercise to check that the graded commutator (2.4) satisfies all properties in the proposition (see also Remark 2.4).

For uniqueness, note first that any operation $\llbracket \cdot, \cdot \rrbracket$ satisfying (i)–(iv) must be local. This can be proven similarly to Proposition 1.2. Therefore, also using \mathbb{R} -bilinearity, it suffices to calculate $\llbracket \cdot, \cdot \rrbracket$ on decomposable multivectors $\vartheta = X_0 \wedge \cdots \wedge X_k$ and $\zeta = Y_0 \wedge \cdots \wedge Y_l$, for $l, k \geq 0$. Using (i)–(iv), we obtain

$$(2.6) \quad \llbracket X_0 \wedge \cdots \wedge X_k, Y_0 \wedge \cdots \wedge Y_l \rrbracket \\ = \sum_{i=0}^k \sum_{j=0}^l (-1)^{i+j} [X_i, Y_j] \wedge X_0 \cdots \widehat{X}_i \cdots X_k \wedge Y_0 \cdots \widehat{Y}_j \cdots Y_l,$$

which shows that these properties determine the operation $\llbracket \cdot, \cdot \rrbracket$, which therefore must coincide with the Schouten bracket. \square

Similarly to vector fields, multivector fields can be pushed forward via diffeomorphisms. This allows one to define the **Lie derivative** of a k -vector field $\vartheta \in \mathfrak{X}^k(M)$ along a vector field $X \in \mathfrak{X}(M)$ as usual by

$$\mathcal{L}_X \vartheta = \left. \frac{d}{dt} \right|_{t=0} (\phi_X^t)^* \vartheta.$$

This definition coincides with the usual Lie derivative along vector fields of functions $f \in C^\infty(M) = \mathfrak{X}^0(M)$ and of vector fields $Y \in \mathfrak{X}(M) = \mathfrak{X}^1(M)$. One can check directly that \mathcal{L}_X is a derivation with respect to the wedge product; i.e., it is \mathbb{R} -linear and satisfies the Leibniz identity:

$$\mathcal{L}_X(\vartheta \wedge \zeta) = \mathcal{L}_X \vartheta \wedge \zeta + \vartheta \wedge \mathcal{L}_X \zeta.$$

Thus, it has the same properties as the operator $[X, -] : \mathfrak{X}^k(M) \rightarrow \mathfrak{X}^k(M)$.

Exercise 2.9. Show that, for any $X \in \mathfrak{X}(M)$ and $\vartheta \in \mathfrak{X}^k(M)$,

$$[X, \vartheta] = \mathcal{L}_X \vartheta.$$

Using the explicit formula for the Schouten bracket we obtain for any bivector field $\pi \in \mathfrak{X}^2(M)$

$$(2.7) \quad (\mathcal{L}_X \pi)(df, dg) = X(\{f, g\}) - \{X(f), g\} - \{f, X(g)\}.$$

In particular, we deduce:

Corollary 2.10. *Given a vector field $X \in \mathfrak{X}(M)$ on a Poisson manifold (M, π) the following statements are equivalent:*

- (i) X is a Poisson vector field.
- (ii) π is invariant under the flow of X or, equivalently, $\mathcal{L}_X \pi = 0$.
- (iii) $[X, \pi] = 0$.

2.2. A slight twist: π^\sharp

There is yet another, slightly different, but useful way to look at Poisson structures. Namely, a bivector field $\pi \in \mathfrak{X}^2(M)$ induces a vector bundle map

$$(2.8) \quad \pi^\sharp : T^*M \rightarrow TM, \quad \alpha \mapsto i_\alpha \pi.$$

By this formula, bivector fields $\pi \in \mathfrak{X}^2(M)$ are in 1-to-1 correspondence with vector bundle maps $\pi^\sharp : T^*M \rightarrow TM$ which are skew-symmetric:

$$(\pi^\sharp)^* = -\pi^\sharp.$$

The map induced between sections will be denoted by the same symbol:

$$\pi^\sharp : \Omega^1(M) \rightarrow \mathfrak{X}^1(M).$$

We can express the condition $[\pi, \pi] = 0$ in terms of the bundle map π^\sharp using the following operation on the space of 1-forms:

$$(2.9) \quad [\alpha, \beta]_\pi := \mathcal{L}_{\pi^\sharp \alpha}(\beta) - \mathcal{L}_{\pi^\sharp \beta}(\alpha) - d(\pi(\alpha, \beta)).$$

The following result details some of its properties.

Proposition 2.11. *Let $\pi \in \mathfrak{X}^2(M)$ be a bivector field with associated biderivation $\{f, g\} = \pi(df, dg)$. The bracket (2.9) is the unique bilinear, skew-symmetric operation on $\Omega^1(M)$ such that the following hold:*

(i) *On exact 1-forms, it is given by*

$$[df, dg]_\pi = d\{f, g\}, \quad \forall f, g \in C^\infty(M).$$

(ii) *It satisfies the Leibniz identity with respect to π^\sharp :*

$$[\alpha, f\beta]_\pi = f[\alpha, \beta]_\pi + \mathcal{L}_{\pi^\sharp(\alpha)}(f)\beta, \quad \forall f \in C^\infty(M), \alpha, \beta \in \Omega^1(M).$$

Moreover, the following are equivalent:

(a) $[\pi, \pi] = 0$.

(b) $\pi^\sharp : (\Omega^1(M), [\cdot, \cdot]_\pi) \rightarrow (\mathfrak{X}^1(M), [\cdot, \cdot])$ preserves the brackets.

(c) $[\cdot, \cdot]_\pi$ satisfies the Jacobi identity.

Remark 2.12. The bracket $[\cdot, \cdot]_\pi$ will play a central role. The properties (ii) and (c) for the triple $(T^*M, [\cdot, \cdot]_\pi, \pi^\sharp)$ are precisely the axioms of a geometric structure called a *Lie algebroid*. This notion will also play an important role later in the book.

Proof. It is straightforward to verify using (2.9) that $[\cdot, \cdot]_\pi$ satisfies (i) and (ii). On the other hand, any \mathbb{R} -bilinear, skew-symmetric operation on 1-forms which satisfies the Leibniz rule (ii) is determined by its values on exact forms; thus if it also satisfies (i), then it must coincide with $[\cdot, \cdot]_\pi$.

For the second part note that by the Leibniz identity (ii) the map

$$U_\pi : \Omega^1(M) \times \Omega^1(M) \rightarrow \mathfrak{X}^1(M), \quad U_\pi(\alpha, \beta) := [\pi^\sharp(\alpha), \pi^\sharp(\beta)] - \pi^\sharp([\alpha, \beta]_\pi)$$

is $C^\infty(M)$ -bilinear. We claim that the following equality holds:

$$\langle \gamma \mid U_\pi(\alpha, \beta) \rangle = \frac{1}{2}[\pi, \pi](\alpha, \beta, \gamma).$$

Since both sides are $C^\infty(M)$ -multilinear, it suffices to check the equality on exact 1-forms: $\alpha = df$, $\beta = dg$, $\gamma = dh$. In this case, by (i) and (2.5), both sides give

$$J_{\{\cdot, \cdot\}}(f, g, h) := \{f, \{g, h\}\} + \{g, \{h, f\}\} + \{h, \{f, g\}\}.$$

This shows that (a) is equivalent to (b).

Next, denote the Jacobiator of the bracket $[\cdot, \cdot]_\pi$ of three 1-forms by

$$J_{[\cdot, \cdot]_\pi}(\alpha, \beta, \gamma) = [\alpha, [\beta, \gamma]_\pi]_\pi + [\beta, [\gamma, \alpha]_\pi]_\pi + [\gamma, [\alpha, \beta]_\pi]_\pi.$$

Using the Leibniz rule repeatedly, one obtains the following equality:

$$J_{[\cdot, \cdot]_\pi}(\alpha, \beta, f\gamma) = f J_{[\cdot, \cdot]_\pi}(\alpha, \beta, \gamma) + \mathcal{L}_{U_\pi(\alpha, \beta)}(f) \gamma.$$

This shows that (c) implies (b). Conversely, if (b) holds, then $J_{[\cdot, \cdot]_\pi}$ is $C^\infty(M)$ -multilinear by the above. On the other hand, using (i) and (a) we find

$$J_{[\cdot, \cdot]_\pi}(df, dg, dh) = dJ_{\{\cdot, \cdot\}}(f, g, h) = 0.$$

We conclude that $J_{[\cdot, \cdot]_\pi} = 0$. Hence, (c) holds. \square

The map π^\sharp allows us to write Hamiltonian vector fields as “ π -gradients”:

$$X_H = \pi^\sharp(dH), \quad H \in C^\infty(M).$$

In particular, the Hamiltonian directions (1.6) are described by the image of π^\sharp :

$$(2.10) \quad \text{Im } \pi_x^\sharp = \{X_{H,x} : H \in C^\infty(M)\} \subset T_x M.$$

Note that $\text{Im } \pi^\sharp$ is a vector subbundle of TM only when π^\sharp has constant rank. In general one should think of it as a *singular* distribution. The proposition shows that the Poisson condition $[\pi, \pi] = 0$ implies the involutivity of this distribution

$$[\pi^\sharp(\alpha), \pi^\sharp(\beta)] \in \text{Im } \pi^\sharp, \quad \forall \alpha, \beta \in \Omega^1(M).$$

We will discuss in Chapter 4 that this singular distribution is integrable and that its associated “singular foliation” has leaves the orbits of (M, π) (for regular and singular foliations see Appendix C).

2.3. Poisson maps and bivector fields

Recall that, given a smooth map $\Phi : M \rightarrow N$, a vector field $X \in \mathfrak{X}(M)$ is said to be **Φ -related** to a vector field $Y \in \mathfrak{X}(N)$ if

$$Y_{\Phi(x)} = (d_x \Phi) X_x, \quad \forall x \in M.$$

In this case Φ maps integral curves of X to integral curves of Y . The vector field Y is not completely determined by the vector field X unless the map Φ is surjective. If X and Y are Φ -related and Φ is surjective, we will write $Y = (\Phi)_* X$ and call Y the **pushforward** of the vector field X .

This generalizes to multivector fields as follows.

Definition 2.13. Let $\Phi : M \rightarrow N$ be a smooth map. A k -vector field $\vartheta \in \mathfrak{X}^k(M)$ is said to be **Φ -related** to a k -vector field $\zeta \in \mathfrak{X}^k(N)$ if

$$\zeta_{\Phi(x)} = (d_x \Phi)_* \vartheta_x, \quad \forall x \in M,$$

where $(d_x \Phi)_* : \bigwedge^k T_x M \rightarrow \bigwedge^k T_{\Phi(x)} N$ is the map induced by the differential of Φ . When Φ is surjective ζ is determined by ϑ , so we write $\zeta = \Phi_* \vartheta$ and we call ζ the **pushforward** of ϑ by the map Φ .

In terms of multiderivations the relation of being Φ -related becomes:

Lemma 2.14. $\vartheta \in \mathfrak{X}^k(M)$ is Φ -related to $\zeta \in \mathfrak{X}^k(N)$ if and only if

$$\mathcal{L}_\vartheta(f_1 \circ \Phi, \dots, f_k \circ \Phi) = \mathcal{L}_\zeta(f_1, \dots, f_k) \circ \Phi, \quad \forall f_1, \dots, f_k \in C^\infty(N).$$

The relation of being Φ -related is compatible with the algebraic operations on multivector fields:

Proposition 2.15. If $\vartheta_i \in \mathfrak{X}^{k_i}(M)$ is Φ -related to $\zeta_i \in \mathfrak{X}^{k_i}(N)$, $i = 1, 2$, then the following hold:

- (i) $a\vartheta_1 + b\vartheta_2$ is Φ -related to $a\zeta_1 + b\zeta_2$, for $a, b \in \mathbb{R}$.
- (ii) $\vartheta_1 \wedge \vartheta_2$ is Φ -related to $\zeta_1 \wedge \zeta_2$.
- (iii) $[\vartheta_1, \vartheta_2]$ is Φ -related to $[\zeta_1, \zeta_2]$.

Proof. Items (i) and (ii) follow immediately from the definition and (iii) follows from the previous lemma. \square

We can now give several characterizations for a map to be Poisson:

Proposition 2.16. Let (M, π_M) and (N, π_N) be Poisson manifolds. Given a smooth map $\Phi : M \rightarrow N$, the following statements are equivalent:

- (i) Φ is a Poisson map.
- (ii) π_M is Φ -related to π_N .

- (iii) For every $f \in C^\infty(N)$, the Hamiltonian vector field $X_{f \circ \Phi}$ is Φ -related to the Hamiltonian vector field X_f .
- (iv) The following diagram commutes for all $x \in M$:

$$\begin{array}{ccc}
 T_x M & \xrightarrow{d_x \Phi} & T_{\Phi(x)} N \\
 \pi_M^\# \uparrow & & \uparrow \pi_N^\# \\
 T_x^* M & \xleftarrow{(d_x \Phi)^*} & T_{\Phi(x)}^* N
 \end{array}$$

Proof. Lemma 2.14 implies immediately the equivalence between (i) and (ii) and between (i) and (iii). On the other hand, (ii) can be written as

$$\begin{aligned}
 & ((d\Phi)_* \pi_M)(\alpha, \beta) = \pi_N(\alpha, \beta) \\
 \iff & ((d\Phi)^* \beta)(\pi_M^\#((d\Phi)^* \alpha)) = \beta(\pi_N^\#(\alpha)) \\
 \iff & \beta(d\Phi(\pi_M^\#((d\Phi)^* \alpha))) = \beta(\pi_N^\#(\alpha)),
 \end{aligned}$$

for all $\alpha, \beta \in T_{\Phi(x)}^* N$. So (ii) is equivalent to (iv). □

Exercise 2.17. Show that a map $\Phi : (M, \pi_M) \rightarrow (N, \pi_N)$ is a Poisson map if and only if

$$\Phi^*[\alpha, \beta]_{\pi_N} = [\Phi^* \alpha, \Phi^* \beta]_{\pi_M}, \quad \forall \alpha, \beta \in \Omega^1(N).$$

2.4. Examples

We consider now many examples of Poisson structures that will be recurrent in later chapters. This includes revisiting the examples in Chapter 1 from the point of view of bivectors, which will provide new insights.

2.4.1. Rank 2 Poisson structures. For a 2-dimensional manifold M the Jacobi identity holds automatically. In the language of bivector fields, we have $\mathfrak{X}^3(M) = 0$, so:

- If $\dim M = 2$, any bivector field $\pi \in \mathfrak{X}^2(M)$ is Poisson: $[\pi, \pi] = 0$.

In the same spirit, on a manifold M of arbitrary dimension one can consider **decomposable bivector fields**:

$$\pi = X \wedge Y,$$

where $X, Y \in \mathfrak{X}(M)$. One finds that

$$[\pi, \pi] = 2[X, Y] \wedge X \wedge Y.$$

In particular, if X and Y commute, then π is a Poisson bivector field. In general, π is a Poisson bivector field if and only if the three vector fields X , Y , and $[X, Y]$ are linearly dependent at every point. If X and Y are

linearly independent everywhere, this condition is equivalent to the distribution spanned by X and Y being involutive (see Section C.1):

$$[X, Y] \in \text{Span}\{X, Y\}.$$

This distribution consists of the Hamiltonian directions (2.10):

$$\text{Span}\{X, Y\} = \pi^\sharp(T^*M) \subset TM.$$

Therefore, by Proposition 1.8, the orbits of π are the leaves of the foliation integrating $\text{Span}\langle X, Y \rangle$. 

2.4.2. Symplectic structures. The canonical Poisson bracket (1.12) on \mathbb{R}^{2s} corresponds to the bivector field

$$\pi_{\text{can}} = \sum_{i=1}^s \frac{\partial}{\partial p_i} \wedge \frac{\partial}{\partial q^i}.$$

This bivector should be seen as the *dual* of the canonical symplectic form (B.4) in Appendix B. Let us explain precisely what this means.

Just as a bivector π induces a bundle map π^\sharp , a 2-form $\omega \in \Omega^2(M)$ determines a vector bundle map

$$\omega^\flat : TM \rightarrow T^*M, \quad v \mapsto i_v \omega.$$

The nondegeneracy of ω is equivalent to ω^\flat being an isomorphism. In this case the inverse is a skew-symmetric map and so it takes the form

$$(2.11) \quad (\omega^\flat)^{-1} = \pi^\sharp : T^*M \rightarrow TM,$$

for some bivector field $\pi \in \mathfrak{X}^2(M)$. Conversely, if π is a **nondegenerate bivector field**, i.e., if $\pi^\sharp : T^*M \rightarrow TM$ is an isomorphism, then it determines a nondegenerate 2-form ω . Note that (2.11) can be rewritten as

$$(2.12) \quad \omega(\pi^\sharp(\alpha), \pi^\sharp(\beta)) = -\pi(\alpha, \beta), \quad \forall \alpha, \beta \in T^*M.$$

In fact, we have:

Proposition 2.18. *The inversion relation (2.11) induces a 1-to-1 correspondence*

$$\left\{ \begin{array}{l} \text{nondegenerate} \\ \text{bivectors } \pi \in \mathfrak{X}^2(M) \end{array} \right\} \xleftrightarrow{\sim} \left\{ \begin{array}{l} \text{nondegenerate} \\ \text{2-forms } \omega \in \Omega^2(M) \end{array} \right\}.$$

Moreover, under this correspondence,

$$(2.13) \quad [\pi, \pi](\alpha, \beta, \gamma) = -d\omega(\pi^\sharp(\alpha), \pi^\sharp(\beta), \pi^\sharp(\gamma)), \quad \forall \alpha, \beta, \gamma \in T^*M.$$

In particular, one obtains a 1-to-1 correspondence

$$\left\{ \begin{array}{l} \text{nondegenerate Poisson} \\ \text{bivectors } \pi \in \mathfrak{X}^2(M) \end{array} \right\} \xleftrightarrow{\sim} \left\{ \begin{array}{l} \text{symplectic} \\ \text{forms } \omega \in \Omega^2(M) \end{array} \right\}.$$

Proof. The first part is clear. It is enough to check (2.13) on exact 1-forms $\alpha = df$, $\beta = dg$, and $\gamma = dh$. Using (2.5) we find that

$$\frac{1}{2}[\pi, \pi](df, dg, dh) = \{f, \{g, h\}\} + \{g, \{h, f\}\} + \{h, \{f, g\}\}.$$

On the other hand, recall the Koszul-type formula for the exterior derivative:

$$\begin{aligned} d\omega(X, Y, Z) &= X(\omega(Y, Z)) + Y(\omega(Z, X)) + Z(\omega(X, Y)) \\ &\quad - (\omega([X, Y], Z) + \omega([Y, Z], X) + \omega([Z, X], Y)). \end{aligned}$$

If we let $X = \pi^\sharp(df)$, $Y = \pi^\sharp(dg)$, and $Z = \pi^\sharp(dh)$, we find

$$d\omega(\pi^\sharp(df), \pi^\sharp(dg), \pi^\sharp(dh)) = -2(\{f, \{g, h\}\} + \{g, \{h, f\}\} + \{h, \{f, g\}\}),$$

so the result follows. \square

2.4.3. Symplectic foliations. Let $\{\omega_t\}_{t \in \mathbb{R}}$ be a smooth 1-parameter family of symplectic forms on a manifold S . These can be arranged into a Poisson bracket $\{\cdot, \cdot\}$ on $M = S \times \mathbb{R}$ by setting

$$\{f, g\}(x, t) = \{f(\cdot, t), g(\cdot, t)\}_t(x),$$

where $\{\cdot, \cdot\}_t$ denotes the Poisson bracket on S induced by ω_t .

Exercise 2.19. Find the orbits of the resulting Poisson manifold $M = S \times \mathbb{R}$.

More generally, whenever we have

- (i) a partition \mathcal{F} of M by submanifolds $S \subset M$ which fit “smoothly” together and
- (ii) a smooth family of symplectic forms ω_S , one for each submanifold $S \in \mathcal{F}$,

we can define a Poisson structure using the similar formula

$$\{f, g\}|_S = \{f|_S, g|_S\}_S, \quad f, g \in C^\infty(M),$$

for any $S \in \mathcal{F}$. Here, $\{\cdot, \cdot\}_S$ denotes the Poisson bracket on S induced by the symplectic form ω_S .

More precisely, the smoothness in (i) means that \mathcal{F} is a regular foliation — see Section C.1. As for the smoothness in (ii), note that the symplectic forms

$$\omega_S \in \Omega^2(S) = \Gamma\left(\bigwedge^2 T^*\mathcal{F}|_S\right) \quad (S \in \mathcal{F})$$

can be put together into a section $\omega_{\mathcal{F}}$ of $\bigwedge^2 T^*\mathcal{F}$. The smoothness of the family amounts to the smoothness of $\omega_{\mathcal{F}}$. In other words, one deals with a regular symplectic foliation $(\mathcal{F}, \omega_{\mathcal{F}})$ — a notion that is explained in more detail in Section C.2.

The bivector field corresponding to $\{\cdot, \cdot\}$ is a bivector along $T\mathcal{F}$,

$$\pi \in \Gamma\left(\bigwedge^2 T\mathcal{F}\right) \subset \Gamma\left(\bigwedge^2 TM\right).$$

The restriction $\pi|_S \in \Gamma(\bigwedge^2 TS)$ to each leaf S becomes precisely the inverse of the symplectic form ω_S as in (2.11). In other words, we have

$$\pi(\alpha, \beta) = -\omega_{\mathcal{F}}(\pi^{\sharp}(\alpha), \pi^{\sharp}(\beta)), \quad \forall \alpha, \beta \in T^*M.$$

As a simple generalization of the previous exercise, the reader can now show that the corresponding orbits are precisely the leaves of the original foliation \mathcal{F} . 

2.4.4. Completely integrable 1-forms. General Poisson structures cannot be described with differential forms, as in the symplectic case. However, in dimension 3 there is still a relationship with 1-forms.

For example, given a Poisson bracket $\{\cdot, \cdot\}$ on \mathbb{R}^3 with structure functions

$$a = \{y, z\}, \quad b = \{z, x\}, \quad c = \{x, y\},$$

consider the 1-form

$$\theta = a dx + b dy + c dz.$$

By a direct computation, the Jacobi identity for $\{\cdot, \cdot\}$ is equivalent to θ being a **completely integrable 1-form**, meaning that

$$\theta \wedge d\theta = 0.$$

Then one obtains a 1-to-1 correspondence

$$\left\{ \begin{array}{c} \text{Poisson} \\ \text{brackets on } \mathbb{R}^3 \end{array} \right\} \xleftrightarrow{\sim} \left\{ \begin{array}{c} \text{completely integrable} \\ \text{1-forms on } \mathbb{R}^3 \end{array} \right\}.$$

In terms of bivector fields this correspondence is given by

$$\pi = a \frac{\partial}{\partial y} \wedge \frac{\partial}{\partial z} + b \frac{\partial}{\partial z} \wedge \frac{\partial}{\partial x} + c \frac{\partial}{\partial x} \wedge \frac{\partial}{\partial y} \quad \longleftrightarrow \quad \theta = a dx + b dy + c dz.$$

For example, any smooth function $C \in C^\infty(\mathbb{R}^3)$ gives rise to an exact completely integrable 1-form: $\theta = dC$. The corresponding Poisson bracket $\{\cdot, \cdot\}_C$ on \mathbb{R}^3 is given by the triple product:

$$(2.14) \quad \{f, g\}_C = (\nabla f \times \nabla g) \cdot \nabla C = \begin{vmatrix} \frac{\partial f}{\partial x} & \frac{\partial f}{\partial y} & \frac{\partial f}{\partial z} \\ \frac{\partial g}{\partial x} & \frac{\partial g}{\partial y} & \frac{\partial g}{\partial z} \\ \frac{\partial C}{\partial x} & \frac{\partial C}{\partial y} & \frac{\partial C}{\partial z} \end{vmatrix}.$$

The linear Poisson bracket (1.18) on $\mathfrak{so}(3, \mathbb{R})^*$ and the quadratic Poisson structure (1.22) on \mathbb{R}^3 are both of this form.

Exercise 2.20. What are the orbits of the Poisson bracket $\{\cdot, \cdot\}_C$?

As explained in Example C.6 of Appendix C, completely integrable 1-forms that are nowhere zero encode codimension-1 foliations. Thus, if

$$\theta_x \neq 0, \quad \forall x \in \mathbb{R}^3,$$

then $\text{Ker } \theta = T\mathcal{F}$ for a 2-dimensional foliation \mathcal{F} on \mathbb{R}^3 . One can show that this case fits into the setting of symplectic foliations as in Subsection 2.4.3 — see Problem 2.5. In particular, the orbits are the leaves of \mathcal{F} .

In general, the orbits for the corresponding Poisson bracket are described in Problem 2.8: they are the zeros of θ and the 2-dimensional leaves lying in the open set where θ is nonvanishing.

Moving now to a general 3-dimensional orientable manifold M , we use the language of bivector fields. Any volume form $\mu \in \Omega^3(M)$ induces an isomorphism

$$\mu^\flat : \bigwedge^2 TM \rightarrow T^*M, \quad X \wedge Y \mapsto \mu(X, Y, \cdot).$$

Hence, any 1-form $\theta \in \Omega^1(M)$ can be “inverted” with respect to μ to a bivector field $\pi \in \mathfrak{X}^2(M)$, giving a 1-to-1 correspondence:

$$\mathfrak{X}^2(M) \xleftarrow{\mu} \Omega^1(M).$$

For $M = \mathbb{R}^3$ with the standard volume form $\mu = dx \wedge dy \wedge dz$ we recover the previous 1-to-1 correspondence.

We leave it as an exercise to check that if π corresponds to θ , then

$$-2\theta \wedge d\theta = (i_\mu[\pi, \pi])\mu.$$

Therefore we deduce:

Proposition 2.21. *A volume form on a 3-dimensional manifold M gives rise to a 1-to-1 correspondence*

$$\left\{ \begin{array}{c} \text{Poisson} \\ \text{structures on } M \end{array} \right\} \xleftrightarrow{\sim} \left\{ \begin{array}{c} \text{completely integrable} \\ \text{1-forms on } M \end{array} \right\}.$$

It follows that the orbits of any orientable 3-dimensional Poisson manifold (M, π) can be determined by choosing a volume form μ , inverting π to a 1-form θ , and then determining the zeros and the 2-dimensional integral submanifolds of θ . For more details, see Problem 2.8.

Exercise 2.22. Use this method to find the orbits of the linear Poisson structure on $\mathfrak{sl}(2, \mathbb{R})^*$ (the dual of the Lie algebra of traceless 2×2 real matrices).

Exercise 2.23. Given an orientable 3-dimensional manifold M , let $f \in C^\infty(M)$ be a Morse function. Show that there exists a Poisson structure on M whose zeros are precisely the critical points of f . 

2.4.5. Constant Poisson structures. Constant Poisson brackets on a vector space V , as in Example 1.21, correspond simply to bivectors

$$\pi \in \bigwedge^2 V$$

interpreted as constant bivector fields. Here we identify a vector $v \in V$ with the constant vector field $x \mapsto \frac{d}{dt}|_{t=0}(x + tv)$. If we fix a basis $\{e_i\}$ of V , then $e_i = \frac{\partial}{\partial x^i}$ where the (x^i) are the corresponding linear coordinates in V . In the corresponding basis of $\bigwedge^2 V$, π has constant coefficients:

$$\pi = \sum_{i < j} c^{ij} \frac{\partial}{\partial x^i} \wedge \frac{\partial}{\partial x^j}, \quad c^{ij} \in \mathbb{R}.$$

The corresponding Poisson bracket is precisely (1.14). The orbits of π discussed in Example 1.21 can now be described in a coordinate-free manner. Namely, the subspace $W \subset V$ spanned by the vectors (1.15) is precisely the image of $\pi^\sharp : V^* \rightarrow V$ and the orbits are simply the translates of W .

This leads to the the following point of view on constant bivectors, which also reveals the symplectic nature of the orbits.

Proposition 2.24. *For any vector space V one has a 1-to-1 correspondence*

$$\left\{ \begin{array}{l} \text{bivectors} \\ \pi \in \bigwedge^2 V \end{array} \right\} \xleftrightarrow{\sim} \left\{ \begin{array}{l} \text{pairs } (W, \omega) \text{ formed by} \\ \text{a subspace } W \subset V \text{ together with} \\ \text{a nondegenerate 2-form } \omega \in \bigwedge^2 W^* \end{array} \right\},$$

which associates to the bivector π the pair

$$W := \text{Im } \pi^\sharp, \quad \omega(\pi^\sharp \alpha, \pi^\sharp \beta) := -\pi(\alpha, \beta),$$

and to the pair (W, ω) there corresponds the bivector

$$(2.15) \quad \pi(\alpha, \beta) := -\omega\left((\omega^\flat)^{-1}(\alpha|_W), (\omega^\flat)^{-1}(\beta|_W)\right).$$

Remark 2.25. The minus signs in the formulas above are introduced so that when the bivector $\pi \in \bigwedge^2 V$ is nondegenerate, we have $W = V$ and $\pi^\sharp = (\omega^\flat)^{-1}$.

Exercise 2.26. Show that a constant Poisson structure is induced by a symplectic foliation. 

2.4.6. Linear Poisson structures. A Poisson structure corresponding to a linear Poisson bracket will be called a **linear Poisson structure**. As discussed in Proposition 1.23, such a Poisson structure corresponds to a Lie algebra $(\mathfrak{g}, [\cdot, \cdot])$. The corresponding bivector field is denoted by

$$\pi_{\mathfrak{g}} \in \mathfrak{X}^2(\mathfrak{g}^*).$$

This linear bivector can be described directly. Namely, the dual of the Lie bracket $[\cdot, \cdot] : \wedge^2 \mathfrak{g} \rightarrow \mathfrak{g}$ is a map $\mathfrak{g}^* \rightarrow \wedge^2 \mathfrak{g}^*$ and can be regarded as a bivector field on \mathfrak{g}^* :

$$\pi_{\mathfrak{g}}|_{\xi} := \xi([\cdot, \cdot]) \in \wedge^2 \mathfrak{g}^* \simeq \wedge^2 T_{\xi} \mathfrak{g}^*, \quad \xi \in \mathfrak{g}^*.$$

Propositions 1.23 and 1.26 can be restated as:

Proposition 2.27. *There is a canonical 1-to-1 correspondence*

$$\left\{ \begin{array}{l} \text{linear Poisson structures} \\ \text{on a vector space } V = \mathfrak{g}^* \end{array} \right\} \xleftrightarrow{\sim} \left\{ \begin{array}{l} \text{Lie algebra structures } [\cdot, \cdot] \\ \text{on the dual vector space } \mathfrak{g} = V^* \end{array} \right\}.$$

Furthermore, the orbits of the linear Poisson structure $(\mathfrak{g}^*, \pi_{\mathfrak{g}})$ coincide with the coadjoint orbits.

If $\{e^i\}$ is a basis of \mathfrak{g} inducing coordinates (x^i) on \mathfrak{g}^* , the linear bivector field has linear coefficients:

$$\pi_{\mathfrak{g}} = \frac{1}{2} \sum_{i,j,k} c_k^{ij} x^k \frac{\partial}{\partial x^i} \wedge \frac{\partial}{\partial x^j},$$

where the c_k^{ij} are the structure constants of \mathfrak{g} for the basis $\{e^i\}$.

Exercise 2.28. Given two Lie algebras $(\mathfrak{g}, [\cdot, \cdot])$ and $(\mathfrak{h}, [\cdot, \cdot])$, check that a linear map $\Psi : \mathfrak{g} \rightarrow \mathfrak{h}$ is a Lie algebra homomorphism if and only if the dual map is a Poisson map $\Psi^* : (\mathfrak{h}^*, \pi_{\mathfrak{h}}) \rightarrow (\mathfrak{g}^*, \pi_{\mathfrak{g}})$. 

2.4.7. Affine Poisson structures. Similarly to linear Poisson structures, one defines an affine Poisson structure on a vector space V as one for which the Poisson bracket of two affine functions is again affine. Fixing linear coordinates (x^i) on V , this condition means that the structure functions must be affine:

$$(2.16) \quad \pi^{ij}(x) = \lambda^{ij} + \sum_k c_k^{ij} x^k.$$

The Poisson condition $[\pi, \pi] = 0$ amounts to two types of equations:

$$\sum_{l=1}^m \left(c_r^{il} c_l^{jk} + c_r^{jl} c_l^{ki} + c_r^{kl} c_l^{ij} \right) = 0 \quad (i, j, k, r = 1, \dots, m);$$

$$\sum_{l=1}^m \left(\lambda^{il} c_l^{jk} + \lambda^{jl} c_l^{ki} + \lambda^{kl} c_l^{ij} \right) = 0 \quad (i, j, k = 1, \dots, m).$$

The first condition means that the c_k^{ij} are the structure constants of a Lie bracket on $\mathfrak{g} = V^*$:

$$[\cdot, \cdot] : \mathfrak{g} \times \mathfrak{g} \rightarrow \mathfrak{g}, \quad [e^i, e^j] := \sum_k c_k^{ij} e^k,$$

where $\{e^i\}$ is the basis of \mathfrak{g} corresponding to the coordinates (x^i) . The first condition is then the Jacobi identity for this bracket:

$$[u, [v, w]] + [v, [w, u]] + [w, [u, v]] = 0, \quad \forall u, v, w \in \mathfrak{g}.$$

To rewrite the second condition, consider the skew-symmetric bilinear map:

$$\lambda : \mathfrak{g} \times \mathfrak{g} \rightarrow \mathbb{R}, \quad \lambda(e^i, e^j) := \lambda^{ij}.$$

Then the second condition is expressed intrinsically in terms of λ as follows:

$$\lambda(u, [v, w]) + \lambda(v, [w, u]) + \lambda(w, [u, v]) = 0, \quad \forall u, v, w \in \mathfrak{g}.$$

This means that λ is a **Lie algebra 2-cocycle** on \mathfrak{g} — a notion recalled in Section A.1.

In conclusion, one obtains:

Proposition 2.29. *There is a 1-to-1 correspondence*

$$\left\{ \begin{array}{l} \text{affine Poisson} \\ \text{structures on } V = \mathfrak{g}^* \end{array} \right\} \xleftrightarrow{\sim} \left\{ \begin{array}{l} \text{Lie algebra structures on } \mathfrak{g} \\ \text{plus a 2-cocycle } \lambda \text{ on } \mathfrak{g} \end{array} \right\}.$$

Given \mathfrak{g} and λ , the corresponding Poisson bivector field will be denoted

$$\pi_{\mathfrak{g}, \lambda} \in \mathfrak{X}^2(\mathfrak{g}^*)$$

and will be called the **affine Poisson structure** associated to (\mathfrak{g}, λ) . The orbits are worked out in Problem 2.10.

Exercise 2.30. Give a coordinate-free interpretation of the correspondence in Proposition 2.29.

The previous discussion does not depend so much on V being a vector space, but rather on being an affine space. While the difference between the two is just the choice of origin, one should still keep in mind that the relevant type of isomorphisms are the affine ones. Using such isomorphisms, one may be able to transform an affine Poisson structure into a linear one. For example, on \mathbb{R}^2 the change of coordinates $u = x + 1, v = y$ transforms the affine Poisson structure defined by $\{x, y\} = x + 1$ into the linear Poisson structure with $\{u, v\} = v$. The following result clarifies when this is possible:

Proposition 2.31. *For any affine Poisson structure $(\mathfrak{g}^*, \pi_{\mathfrak{g}, \lambda})$, the following are equivalent:*

- (i) *There is an affine Poisson diffeomorphism $\Psi : (\mathfrak{g}^*, \pi_{\mathfrak{g}}) \rightarrow (\mathfrak{g}^*, \pi_{\mathfrak{g}, \lambda})$.*
- (ii) *There is a Poisson diffeomorphism $\Phi : (\mathfrak{g}^*, \pi_{\mathfrak{g}}) \rightarrow (\mathfrak{g}^*, \pi_{\mathfrak{g}, \lambda})$.*
- (iii) *The Poisson bivector $\pi_{\mathfrak{g}, \lambda}$ vanishes at least at one point.*

(iv) The Lie algebra 2-cocycle $\lambda : \bigwedge^2 \mathfrak{g} \rightarrow \mathbb{R}$ is exact:

$$\lambda(u, v) = \xi([u, v]),$$

for some linear map $\xi : \mathfrak{g} \rightarrow \mathbb{R}$.

Proof. Clearly, (i) \Rightarrow (ii) \Rightarrow (iii). Fixing a basis as above, by (2.16) the condition that $\pi_{\mathfrak{g}, \lambda}$ vanishes at the point $-\xi \in \mathfrak{g}^*$ can be written as

$$\lambda^{ij} = \sum_k c_k^{ij} \xi^k, \quad \text{where } \xi = (\xi^1, \dots, \xi^m).$$

This is precisely the condition for the cocycle λ to be exact, so (iii) \Rightarrow (iv). Finally, for (iv) \Rightarrow (i), observe that the last formula the translation $\Psi(x) = x + \xi$ gives an affine isomorphism between $\pi_{\mathfrak{g}, \lambda}$ and $\pi_{\mathfrak{g}}$. \square

Exercise 2.32. Find affine Poisson structures that are symplectic.

Constant Poisson structures can be viewed as the affine Poisson structures whose underlying Lie algebra is abelian. However, the only constant Poisson structure that satisfies the conditions of the proposition is the zero Poisson structure.

For interesting classes of Lie algebras the *second Lie algebra cohomology* vanishes; i.e., condition (iv) always holds. This includes the semisimple Lie algebras — see Theorem A.1 — and also other examples such as the following:

Exercise 2.33. Prove that for the nonabelian 2-dimensional Lie algebra

$$\mathfrak{g} = \mathbb{R}^2, \quad [e_1, e_2] = e_1,$$

any 2-cocycle λ is exact. 

2.4.8. Families of Poisson structures. Generalizing families of symplectic structures, any smooth family of Poisson bivectors $\{\pi_t\}_{t \in \mathbb{R}}$ on a manifold M gives a Poisson structure on $M \times \mathbb{R}$ with bivector field

$$\tilde{\pi}(x, t) = \pi_t(x) \quad (\text{no } \frac{\partial}{\partial t} \text{ component}).$$

For an interesting example, let \mathfrak{g} be a Lie algebra endowed with a 2-cocycle λ . Since $t\lambda$ is a 2-cocycle for each $t \in \mathbb{R}$, we obtain a family of affine Poisson structures on \mathfrak{g}^* : $\{\pi_{\mathfrak{g}, t\lambda}\}_{t \in \mathbb{R}}$. The resulting Poisson structure $\tilde{\pi}$ on $\mathfrak{g}^* \times \mathbb{R}$ is given in linear coordinates by

$$\{x^i, x^j\} = t \lambda^{ij} + \sum_k c_k^{ij} x^k, \quad \{t, x^i\} = 0.$$

In particular, it is a linear Poisson structure on $\mathfrak{g}^* \times \mathbb{R} = (\mathfrak{g} \oplus \mathbb{R})^*$. Hence, we have recovered a well-known fact: a 2-cocycle λ on \mathfrak{g} defines a **central**

extension Lie algebra $\widetilde{\mathfrak{g}}_\lambda = \mathfrak{g} \oplus \mathbb{R}$ of \mathfrak{g} with Lie bracket:

$$[(u, r), (v, s)]_{\widetilde{\mathfrak{g}}_\lambda} := ([u, v]_{\mathfrak{g}}, \lambda(u, v)).$$

Of course, one can also check directly that the Jacobi identity for $\widetilde{\mathfrak{g}}_\lambda$ is equivalent to the Jacobi identity for \mathfrak{g} , together with the 2-cocycle condition for λ .

Problems

2.1. Find the Schouten bracket $[\pi, \pi]$ for the following bivector fields:

- (a) $\pi = \frac{\partial}{\partial x^1} \wedge \frac{\partial}{\partial x^2} + \cdots + \frac{\partial}{\partial x^{2n-1}} \wedge \frac{\partial}{\partial x^{2n}} \in \mathfrak{X}^2(\mathbb{R}^{2n})$.
- (b) $\pi = f(\theta^1) \frac{\partial}{\partial \theta^1} \wedge \frac{\partial}{\partial \theta^2} + \frac{\partial}{\partial \theta^3} \wedge \frac{\partial}{\partial \theta^4} + \cdots + \frac{\partial}{\partial \theta^{2n-1}} \wedge \frac{\partial}{\partial \theta^{2n}} \in \mathfrak{X}^2(\mathbb{T}^{2n})$.
- (c) $\pi = f(x) \frac{\partial}{\partial y} \wedge \frac{\partial}{\partial z} + g(y) \frac{\partial}{\partial z} \wedge \frac{\partial}{\partial x} + h(z) \frac{\partial}{\partial x} \wedge \frac{\partial}{\partial y} \in \mathfrak{X}^2(\mathbb{R}^3)$.

2.2. Let (M, π) be a Poisson manifold. If $X, Y \in \mathfrak{X}(M)$ are commuting Poisson vector fields, show that $\pi + X \wedge Y \in \mathfrak{X}^2(M)$ is a Poisson bivector field.

2.3. Let (M, π) be a Poisson manifold.

- (a) If $X \in \mathfrak{X}(M)$ is a vector field, show that the bivector field on $M \times \mathbb{R}$

$$\tilde{\pi}_X := \pi + X \wedge \frac{\partial}{\partial t} \in \mathfrak{X}^2(M \times \mathbb{R})$$

is a Poisson bivector if and only if X is a Poisson vector field for (M, π) .

- (b) Similarly, but one dimension higher, if $X, Y \in \mathfrak{X}(M)$ are commuting vector fields, show that the bivector field on $M \times \mathbb{R}^2$

$$\tilde{\pi}_{X,Y,\lambda} := \pi + X \wedge \frac{\partial}{\partial t} + Y \wedge \frac{\partial}{\partial s} + \lambda \frac{\partial}{\partial t} \wedge \frac{\partial}{\partial s}$$

is a Poisson bivector for any constant $\lambda \in \mathbb{R}$ if and only if X and Y are Poisson vector fields for (M, π) .

- (c) Extend (a) and (b) for any finite number of commuting vector fields.

2.4. Let E be the Euler vector field from Problem 1.5, and let $d \in \mathbb{Z}$ be an integer. A Poisson bivector π on \mathbb{R}^n is said to be *homogenous of degree d* if

$$\mathcal{L}_E \pi = d \pi.$$

Show the following:

- (a) For $d = 0, 1, 2$ one recovers precisely the notions of constant, linear, and quadratic Poisson bivectors, respectively.

- (b) If $m_t : \mathbb{R}^n \rightarrow \mathbb{R}^n$ denotes scalar multiplication by $t \in \mathbb{R}$, then π is homogeneous of degree d if and only if

$$(m_t)_*\pi = t^{2-d}\pi, \quad \forall t > 0.$$

2.5. Assume that θ is a nowhere vanishing completely integrable 1-form on \mathbb{R}^3 , so that $\text{Ker } \theta$ defines a foliation \mathcal{F} on \mathbb{R}^3 . Show the following:

- (a) There exists a 2-form on \mathbb{R}^3 such that $\theta \wedge \omega$ is the standard volume form $dx \wedge dy \wedge dz$.
- (b) Restricting ω to $T\mathcal{F}$, the resulting foliated 2-form $\omega_{\mathcal{F}}$ does not depend on the choice of ω .
- (c) $(\mathcal{F}, \omega_{\mathcal{F}})$ is a symplectic foliation.
- (d) The Poisson structures associated with θ , as in Subsection 2.4.4, and with $(\mathcal{F}, \omega_{\mathcal{F}})$, as in Subsection 2.4.3, coincide.
- (e) If S is a nonorientable surface in \mathbb{R}^3 (e.g., the Möbius band), then there is no Poisson bracket on \mathbb{R}^3 admitting S as an orbit.

2.6. Let μ be a volume form on a 3-dimensional manifold M . Prove the claim from Subsection 2.4.4: if $\pi \in \mathfrak{X}^2(M)$ is the inverse of $\theta \in \Omega^1(M)$ relative to μ , then

$$-2\theta \wedge d\theta = (i_{\mu}[\pi, \pi])\mu.$$

2.7. Show that if $\pi \in \mathfrak{X}^2(M)$ is a Poisson structure on a 3-dimensional manifold, then $f\pi$ is also a Poisson structure, for any $f \in C^\infty(M)$. What about in dimension 4?

2.8. Let π be a Poisson structure on an oriented 3-manifold M with volume form μ and corresponding completely integrable 1-form $\theta \in \Omega^1(M)$ (see Subsection 2.4.4). Denote by $U \subset M$ the open set where $\theta_x \neq 0$.

- (a) Prove that $\theta(X_f) = 0$ for any Hamiltonian vector field X_f .
- (b) Show that the orbits of π consist of points in $M \setminus U$ and leaves of the foliation integrating the distribution $\text{Ker } \theta|_U$.

2.9. Show that for any finite-dimensional vector space V , the assignment $\pi \mapsto \pi^\sharp$, defined as in (2.8), gives a linear 1-to-1 correspondence

$$\left\{ \begin{array}{l} \text{constant bivectors} \\ \pi \in \wedge^2 V \end{array} \right\} \xleftrightarrow{\sim} \left\{ \begin{array}{l} \text{linear maps } A : V^* \rightarrow V \\ \text{that are anti-self-dual; i.e., } A^* = -A \end{array} \right\}.$$

2.10. Let $\lambda : \wedge^2 \mathfrak{g} \rightarrow \mathbb{R}$ be a Lie algebra 2-cocycle as in Subsection 2.4.7. Using the fact that the orbits of a linear Poisson structure are the coadjoint orbits, show that the orbits of the affine Poisson manifold $(\mathfrak{g}^*, \pi_{\mathfrak{g}, \lambda})$ coincide

with the orbits of an action

$$\tilde{G}_\lambda \times \mathfrak{g}^* \rightarrow \mathfrak{g}^*,$$

where \tilde{G}_λ is a connected Lie group integrating the central extension Lie algebra $\tilde{\mathfrak{g}}_\lambda = \mathfrak{g} \oplus \mathbb{R}$.

2.11. An action $\mathcal{a} : \mathfrak{g} \rightarrow \mathfrak{X}(M)$ can be interpreted as a bivector field $\mathcal{a} \in \mathfrak{X}^2(M \times \mathfrak{g}^*)$, where for $(x, \xi) \in M \times \mathfrak{g}^*$ one views $\mathcal{a}_x : \mathfrak{g} \rightarrow T_x M$ as an element

$$\mathcal{a}_{x, \xi} \in \mathfrak{g}^* \otimes T_x M \cong T_\xi \mathfrak{g}^* \otimes T_x M.$$

For a bivector field $\pi \in \mathfrak{X}^2(M)$, define the bivector field on $M \times \mathfrak{g}^*$:

$$\Pi_{\mathfrak{g}, \mathcal{a}} := \pi + \mathcal{a} + \pi_{\mathfrak{g}} \in \mathfrak{X}^2(M \times \mathfrak{g}^*).$$

Show the following:

- (a) $\Pi_{\mathfrak{g}, \mathcal{a}}$ is Poisson if and only if π is Poisson and \mathcal{a} is a Poisson action.
- (b) Assuming (a) and that $\mathcal{a} : \mathfrak{g} \rightarrow \mathfrak{X}(M)$ integrates to a Poisson action $G \times M \rightarrow M$, show that the diagonal action of G on $M \times \mathfrak{g}^*$, where G acts via the coadjoint action in the second factor, is Hamiltonian with moment map the projection $\mu : M \times \mathfrak{g}^* \rightarrow \mathfrak{g}^*$.

2.12. For a Poisson manifold (M, π) define the linear map

$$d_\pi : \mathfrak{X}^k(M) \rightarrow \mathfrak{X}^{k+1}(M), \quad d_\pi \vartheta := [\pi, \vartheta].$$

- (a) Show that d_π is a differential: $d_\pi^2 = 0$.
- (b) What is the meaning of the *first Poisson cohomology group*

$$H_\pi^1(M) := \frac{\text{Ker}(d_\pi : \mathfrak{X}^1(M) \rightarrow \mathfrak{X}^2(M))}{\text{Im}(d_\pi : \mathfrak{X}^0(M) \rightarrow \mathfrak{X}^1(M))} ?$$

2.13. For any 1-form $\alpha \in \Omega^1(M)$, define the interior product with α by

$$i_\alpha : \mathfrak{X}^k(M) \rightarrow \mathfrak{X}^{k-1}(M), \quad i_\alpha \vartheta(\alpha_1, \dots, \alpha_{k-1}) = \vartheta(\alpha, \alpha_1, \dots, \alpha_{k-1}),$$

and the operator $\mathcal{L}_\alpha : \mathfrak{X}^k(M) \rightarrow \mathfrak{X}^k(M)$ by (see the previous exercise)

$$\mathcal{L}_\alpha := d_\pi i_\alpha + i_\alpha d_\pi.$$

Show that \mathcal{L}_α is a derivation of the algebra $(\mathfrak{X}^\bullet(M), \wedge)$ which satisfies

- (a) $\mathcal{L}_\alpha d_\pi = d_\pi \mathcal{L}_\alpha$,
- (b) $i_{[\alpha, \beta]_\pi} = [\mathcal{L}_\alpha, i_\beta] = [i_\alpha, \mathcal{L}_\beta]$,
- (c) $\mathcal{L}_{[\alpha, \beta]_\pi} = [\mathcal{L}_\alpha, \mathcal{L}_\beta]$,

where the bracket in right-hand side of (b) and (c) is the usual commutator: $[A, B] = A \circ B - B \circ A$.

Local Structure of Poisson Manifolds

Poisson structures can exhibit a very rich and interesting geometry, even locally. In this chapter we will discuss some classical aspects of the local structure of Poisson manifolds. The main result of the chapter, the Weinstein Splitting Theorem, states that a Poisson manifold is locally the product of a symplectic manifold and of a Poisson manifold with a zero. This yields a very simple local structure for regular Poisson manifolds. It follows that, to understand a general Poisson manifold locally, it suffices to look around zeros. At such a point there is a canonical first-order approximation of the Poisson bivector — the linear Poisson structure corresponding to the *isotropy Lie algebra*. The linearization problem asks whether a Poisson structure is locally isomorphic around a zero to its first-order approximation. In the end of this chapter we will discuss Conn's Linearization Theorem, a deep, difficult, and beautiful result in Poisson geometry.

3.1. The Weinstein Splitting Theorem

Definition 3.1. For a bivector field $\pi \in \mathfrak{X}^2(M)$ the dimension of the image of $\pi_x^\sharp : T_x^*M \rightarrow T_xM$ is called the **rank** of π at $x \in M$.

For a Poisson bivector the rank is the dimension of the Hamiltonian directions (2.10). By skew-symmetry, it is an even integer. Moreover, the rank cannot drop locally: every $x \in M$ has a neighborhood U such that

$$\text{rank } \pi_x \leq \text{rank } \pi_y, \quad \forall y \in U.$$

Recall that π is called a nondegenerate bivector field if $\pi^\sharp : T^*M \rightarrow TM$ is a vector bundle isomorphism or, equivalently, if $\text{rank } \pi_x = \dim M$, for all $x \in M$. As discussed in the previous chapter, in this case $\omega = \pi^{-1}$ is a symplectic structure. So by Darboux's Theorem, Theorem B.7, π can be put locally in the canonical form

$$\pi = \sum_{i=1}^s \frac{\partial}{\partial p_i} \wedge \frac{\partial}{\partial q^i} \quad (2s = \dim M).$$

The following important result generalizes Darboux's Theorem and is the Poisson geometric analogue of Frobenius's Theorem:

Theorem 3.2 (Weinstein Splitting Theorem). *Let (M, π) be a Poisson manifold, and let $x \in M$. There exist coordinates $(U, p_1, \dots, p_s, q^1, \dots, q^s, y^1, \dots, y^q)$ centered at x such that*

$$\pi|_U = \sum_{i=1}^s \frac{\partial}{\partial p_i} \wedge \frac{\partial}{\partial q^i} + \sum_{1 \leq a < b \leq q} \theta^{ab}(y) \frac{\partial}{\partial y^a} \wedge \frac{\partial}{\partial y^b} \quad (2s = \text{rank } \pi_x),$$

where the $\theta^{ab}(y)$ are smooth functions of (y^1, \dots, y^q) such that $\theta^{ab}(0) = 0$.

Note that, by shrinking U , the chart $\chi = (p_1, \dots, p_s, q^1, \dots, q^s, y^1, \dots, y^q)$ can be chosen such that $\chi(U) = V \times W$, where $V \subset \mathbb{R}^{2s}$ and $W \subset \mathbb{R}^q$ are open neighborhoods of 0. These **Weinstein splitting charts** give local Poisson isomorphisms with a product

$$(3.1) \quad \chi : (U, \pi|_U) \xrightarrow{\sim} (V, \pi_{\text{can}}) \times (W, \theta),$$

where π_{can} is the canonical Poisson structure on \mathbb{R}^{2s} and

$$\theta = \sum_{a < b} \theta^{ab}(y) \frac{\partial}{\partial y^a} \wedge \frac{\partial}{\partial y^b} \in \mathfrak{X}^2(W)$$

is a Poisson structure that vanishes at the point $y = 0$. Such charts should be seen as the Poisson analogue of the

- *Darboux charts* for symplectic structures,
- charts resulting from the Frobenius Theorem, which we call *foliated charts*.

See the discussion concerning Theorems B.7 and C.3. Accordingly, the Weinstein Splitting Theorem is the Poisson analogue of the theorems of Darboux and Frobenius.

In the next chapter we will use the splitting charts to define the smooth structure on the orbits of a Poisson manifold, in a similar way as one uses Frobenius's Theorem to describe the leaves of regular foliations. Namely, note that, for a splitting chart (3.1), the submanifold

$$V_0 := \chi^{-1}(V \times \{0\}) = \{y^1 = 0, \dots, y^q = 0\}$$

plays the role of the *plaque* through $x \in M$ for $\text{Im } \pi^\sharp$. In other words, since $\theta(0) = 0$, the Hamiltonian directions are given by

$$\text{Im } \pi^\sharp|_{V_0} = \text{Span} \left\{ \frac{\partial}{\partial p_1}, \dots, \frac{\partial}{\partial p_s}, \frac{\partial}{\partial q^1}, \dots, \frac{\partial}{\partial q^s} \right\}.$$

In general, for $y \neq 0$, the submanifold $V_y := \chi^{-1}(V \times \{y\})$ is not necessarily a plaque of $\text{Im } \pi^\sharp$, as only one inclusion holds:

$$\text{Im } \pi^\sharp|_{V_y} \supset \text{Span} \left\{ \frac{\partial}{\partial p_1}, \dots, \frac{\partial}{\partial p_s}, \frac{\partial}{\partial q^1}, \dots, \frac{\partial}{\partial q^s} \right\}.$$

For the proof of the Weinstein Splitting Theorem, we need the following standard lemma, which is a consequence of the flow box theorem (the case $k = 1$) and the fact that flows of commuting vector fields also commute for small times.

Lemma 3.3. *Let V_1, \dots, V_k be vector fields defined on a neighborhood of $x \in M$, which are linearly independent at x and pairwise commute:*

$$[V_i, V_j] = 0, \quad 1 \leq i, j \leq k.$$

Then there exists a chart centered at x , (U, x^1, \dots, x^m) , such that

$$(3.2) \quad V_i|_U = \frac{\partial}{\partial x^i}, \quad 1 \leq i \leq k.$$

Proof of Theorem 3.2. We will prove the statement by induction on the rank π_x . If $\text{rank } \pi_x = 0$, there is nothing to prove. Assume that $\text{rank } \pi_x > 0$ and that the result holds for any Poisson structure with rank smaller than $\text{rank } \pi_x$.

Since $\pi_x \neq 0$ there exists a function p defined around x such that $p(x) = 0$ and $X_p|_x = \pi_x^\sharp(\text{d}_x p) \neq 0$. By Lemma 3.3 we can find a coordinate chart (U, x^1, \dots, x^m) centered at x in which $X_p|_U = \frac{\partial}{\partial x^1}$. Set $q := x^1$. Observe that the relations

$$X_p(p) = 0, \quad X_q(q) = 0, \quad X_p(q) = \{p, q\} = 1, \quad X_q(p) = \{q, p\} = -1$$

imply that X_p and X_q are linearly independent. These vector fields commute:

$$[X_p, X_q] = X_{\{p, q\}} = X_1 = 0.$$

Lemma 3.3 gives a new chart centered at x , still denoted (U, x^1, \dots, x^m) , such that

$$(3.3) \quad X_q|_U = \frac{\partial}{\partial x^1}, \quad X_p|_U = \frac{\partial}{\partial x^2}.$$

After possibly shrinking U , $(U, q, p, x^3, \dots, x^m)$ is also a coordinate system centered at x . This follows because the differentials of these functions are independent:

$$\begin{aligned} dq \wedge dp \wedge dx^3 \wedge \dots \wedge dx^m &= \left(\frac{\partial q}{\partial x^1} \frac{\partial p}{\partial x^2} - \frac{\partial q}{\partial x^2} \frac{\partial p}{\partial x^1} \right) dx^1 \wedge \dots \wedge dx^m \\ &= dx^1 \wedge \dots \wedge dx^m, \end{aligned}$$

where in the last equality we have used the relations

$$\begin{aligned} \frac{\partial p}{\partial x^1} &= X_q(p) = -1, & \frac{\partial p}{\partial x^2} &= X_p(p) = 0, \\ \frac{\partial q}{\partial x^1} &= X_q(q) = 0, & \frac{\partial q}{\partial x^2} &= X_p(q) = 1. \end{aligned}$$

By (3.3), the new coordinates $(U, q, p, x^3, \dots, x^m)$ satisfy

$$\{p, q\} = 1, \quad \{p, x^i\} = 0, \quad \{q, x^i\} = 0 \quad (3 \leq i \leq m).$$

Therefore, π takes the form

$$\pi|_U = \frac{\partial}{\partial p} \wedge \frac{\partial}{\partial q} + \sum_{3 \leq a < b \leq m} \theta^{ab}(q, p, x^3, \dots, x^m) \frac{\partial}{\partial x^a} \wedge \frac{\partial}{\partial x^b}.$$

Hence, in these coordinates $X_p|_U = \frac{\partial}{\partial q}$ and $X_q|_U = -\frac{\partial}{\partial p}$. On the other hand, the Jacobi identity gives

$$\frac{\partial}{\partial q}(\theta^{ab}) = X_p(\theta^{ab}) = \{p, \{x^a, x^b\}\} = \{\{p, x^a\}, x^b\} + \{x^a, \{p, x^b\}\} = 0,$$

and similarly $\frac{\partial}{\partial p}(\theta^{ab}) = 0$. So, after possibly shrinking U again, we may assume that the functions θ^{ab} do not depend on the variables p and q . The Jacobi identity for the variables x^3, \dots, x^m shows that

$$\theta = \sum_{3 \leq a < b \leq m} \theta^{ab}(x^3, \dots, x^m) \frac{\partial}{\partial x^a} \wedge \frac{\partial}{\partial x^b}$$

is a Poisson structure defined around 0 in \mathbb{R}^{m-2} . Note that

$$\text{rank } \theta_0 = \text{rank } \pi_x - 2.$$

So the theorem follows by applying the induction hypothesis to θ . \square

3.2. Regular points

Definition 3.4. Let (M, π) be a Poisson manifold. One calls $x \in M$ a **regular point** if the rank of π is constant in a neighborhood of x . Otherwise, x is called a **singular point**.

The properties of the rank imply that the set of regular points of a Poisson manifold is open and dense.

It is instructive to illustrate the Weinstein Splitting Theorem around a regular point. Then, in a splitting chart $(U, p_1, \dots, p_s, q^1, \dots, q^s, y^1, \dots, y^q)$ the Poisson structure becomes constant,

$$\pi|_U = \sum_{i=1}^s \frac{\partial}{\partial p_i} \wedge \frac{\partial}{\partial q^i},$$

and the Hamiltonian directions are given by

$$\text{Im } \pi^\sharp|_U = \text{Span} \left\{ \frac{\partial}{\partial p_1}, \dots, \frac{\partial}{\partial p_s}, \frac{\partial}{\partial q^1}, \dots, \frac{\partial}{\partial q^s} \right\}.$$

Hence, around a regular point, $\text{Im } \pi^\sharp$ becomes a regular involutive distribution. For the associated regular foliation the Weinstein splitting charts are a special kind of foliation charts. We see that π is associated with a symplectic foliation as in Subsection 2.4.3, with leaves given by $\{y = y_0\}$, with $y_0 \in \mathbb{R}^q$, and leafwise symplectic forms

$$\omega_{y_0} = \sum_{i=1}^s dq^i \wedge dp_i.$$

In this case, Weinstein's Splitting Theorem becomes the foliated Darboux Theorem stated as Theorem C.15. We will treat this class of examples in full detail and from a global perspective in the next chapter.

3.3. Singular points

As we have seen, Poisson structures admit a simple local form around regular points. In contrast, they can have a very complicated behavior around singular points.

Let us look on \mathbb{R}^2 where any bivector field is Poisson:

$$(3.4) \quad \pi = f(x, y) \frac{\partial}{\partial x} \wedge \frac{\partial}{\partial y}.$$

At a singular point (x_0, y_0) , we have $f(x_0, y_0) = 0$ and f does not vanish identically on a neighborhood of (x_0, y_0) . However, because f can be any smooth function with these properties, the general local classification of such bivectors is beyond our current understanding — for the known results, see [12, 124] or [105, Section 9.1].

The case of a generic singular point is covered by the following result:

Proposition 3.5. *Consider a Poisson structure on \mathbb{R}^2 that vanishes transversely at the origin:*

$$\pi = f(x, y) \frac{\partial}{\partial x} \wedge \frac{\partial}{\partial y}, \quad f(0) = 0, \quad d_0 f \neq 0.$$

There is a chart $(U, (u, v))$ centered at 0, such that

$$\pi|_U = u \frac{\partial}{\partial u} \wedge \frac{\partial}{\partial v}.$$

Proof. By assumption, we may apply Lemma 3.3 to the vector field:

$$V = \frac{\partial f}{\partial y} \frac{\partial}{\partial x} - \frac{\partial f}{\partial x} \frac{\partial}{\partial y}.$$

Hence, there is a smooth function g , which vanishes at the origin, such that

$$\mathcal{L}_V g = -1 \iff \frac{\partial f}{\partial y} \frac{\partial g}{\partial x} - \frac{\partial f}{\partial x} \frac{\partial g}{\partial y} = -1.$$

Thus, we can use f and g as new coordinates around the origin:

$$u = f(x, y), \quad v = g(x, y).$$

In these new coordinates we find that

$$\{u, v\} = \{f, g\} = f \left(\frac{\partial f}{\partial x} \frac{\partial g}{\partial y} - \frac{\partial f}{\partial y} \frac{\partial g}{\partial x} \right) = f = u.$$

Equivalently, $\pi = u \frac{\partial}{\partial u} \wedge \frac{\partial}{\partial v}$. □

In general, as the order of the singularity grows, there are more and more possible canonical forms for the Poisson structure, which may depend on several parameters. For example, for a Poisson structure (3.4) with

$$f(0) = 0, \quad d_0 f = 0, \quad \det(\text{Hess}_0 f) \neq 0,$$

one can show that there is a chart $(U, (u, v))$ centered at 0, such that

$$\pi|_U = a(u^2 + v^2) \frac{\partial}{\partial u} \wedge \frac{\partial}{\partial v} \quad \text{or} \quad \pi|_U = a(u^2 - v^2) \frac{\partial}{\partial u} \wedge \frac{\partial}{\partial v},$$

for some real number $a > 0$ — see [12] or [124]. We leave it as an exercise to check that these Poisson structures are not isomorphic for different values of a .

If one considers instead a bivector field (3.4) that is flat at 0, i.e., one for which the derivatives of f of any order vanish at 0, then there is no polynomial canonical form.

In higher dimensions, a general bivector field can have singularities where the rank is nonzero. However, for *Poisson* bivector fields, the Weinstein Splitting Theorem allows one to consider only singularities with zero rank. The Jacobi identity can be even further exploited to obtain canonical forms that do not hold for arbitrary bivector fields.

We illustrate this phenomenon by giving the local canonical form for an important class of examples, generalizing Proposition 3.5.

Example 3.6 (Log-symplectic Poisson structures). Let M be an even-dimensional manifold; say $\dim M = 2n$. Then $\bigwedge^{2n} TM$ is a line bundle and any bivector field $\pi \in \mathfrak{X}^2(M)$ yields a section:

$$\bigwedge^n \pi \in \Gamma\left(\bigwedge^{2n} TM\right).$$

This section vanishes precisely at the points x where $\text{rank } \pi_x < \dim M$.

A Poisson manifold (M^{2n}, π) is called **log-symplectic** if the section $\bigwedge^n \pi$ is transverse to the zero section of $\bigwedge^{2n} TM$. This can be rephrased as follows. In a local chart (U, x^1, \dots, x^{2n}) , we have

$$\bigwedge^n \pi|_U = f \frac{\partial}{\partial x^1} \wedge \cdots \wedge \frac{\partial}{\partial x^{2n}},$$

for some function $f \in C^\infty(U)$. Then the transversality condition means that $d_x f \neq 0$ at any zero of f . Note that the structure from Proposition 3.5 is of this type.

Transversality implies that the zero set of $\bigwedge^n \pi$,

$$Z := \left(\bigwedge^n \pi\right)^{-1}(0),$$

is a codimension-1 submanifold of M . Since Z is the set where $\text{rank } \pi$ is not locally constant, we call Z the **singular locus** of (M, π) .

The restriction of π to the complement of Z is nondegenerate, and so $M \setminus Z$ can be covered by Darboux charts putting π in canonical form. By applying the Weinstein Splitting Theorem and Proposition 3.5, one obtains a simple local form for π also around points on the singular locus Z :

Proposition 3.7. *Let (M^{2n}, π) be a log-symplectic manifold with singular locus Z . For any $x \in Z$ one can choose local coordinates (U, u, v, p_i, q^i) , $1 \leq i \leq n-1$, centered at x , such that $U \cap Z = \{u = 0\}$ and*

$$\pi|_U = u \frac{\partial}{\partial u} \wedge \frac{\partial}{\partial v} + \sum_{i=1}^{n-1} \frac{\partial}{\partial p_i} \wedge \frac{\partial}{\partial q^i}.$$

Remark 3.8. If we invert $\pi|_U$, we obtain the “singular” 2-form:

$$(\pi|_U)^{-1} = \frac{1}{u} dv \wedge du + \sum_{i=1}^{n-1} dq^i \wedge dp_i = dv \wedge d \log |u| + \sum_{i=1}^{n-1} dq^i \wedge dp_i.$$

So we have a symplectic form that blows up with a logarithmic singularity along Z . This is the reason for the term “log-symplectic”.

Proof of Proposition 3.7. Let $(U, p_1, \dots, p_s, q^1, \dots, q^s, y^1, \dots, y^{2k})$ be Weinstein splitting coordinates centered at $x \in Z$ (where $n = s + k$):

$$\pi|_U = \theta + \pi_{\text{can}} = \sum_{1 \leq a < b \leq 2k} \theta^{ab}(y) \frac{\partial}{\partial y^a} \wedge \frac{\partial}{\partial y^b} + \sum_{i=1}^s \frac{\partial}{\partial p_i} \wedge \frac{\partial}{\partial q^i}.$$

Then

$$\bigwedge^{k+s} \pi|_U = \frac{(k+s)!}{k!} \bigwedge^k \theta \wedge \frac{\partial}{\partial p_1} \wedge \frac{\partial}{\partial q^1} \wedge \dots \wedge \frac{\partial}{\partial p_s} \wedge \frac{\partial}{\partial q^s}.$$

If $k > 1$, then $\bigwedge^k \theta$ vanishes at 0 to order greater than 1, contradicting that $\bigwedge^{k+s} \pi$ is transverse to the zero section. Hence, we must have $k = 1$, and so

$$\pi|_U = \theta^{12}(y^1, y^2) \frac{\partial}{\partial y^1} \wedge \frac{\partial}{\partial y^2} + \sum_{i=1}^{n-1} \frac{\partial}{\partial p_i} \wedge \frac{\partial}{\partial q^i},$$

with $\theta^{12}(0, 0) = 0$. Transversality of $\bigwedge^n \pi$ implies that $d_{(0,0)} \theta^{12} \neq 0$, so the result now follows from Proposition 3.5. \square

Exercise 3.9. Show that any compact surface (oriented or not) admits a log-symplectic structure. 

The study of singularities of Poisson structures is an intricate subject and there are relatively few general results. The related problem of linearizing Poisson structures will be discussed in Section 3.5.

3.4. The isotropy Lie algebra

Let (M, π) be a Poisson manifold and fix $x \in M$. Recall that, by Proposition 2.11, the space of 1-forms $\Omega^1(M)$ has a Lie bracket $[\cdot, \cdot]_\pi$. This bracket induces a Lie bracket on the subspace

$$\text{Ker } \pi_x^\sharp \subset T_x^* M.$$

This is shown in the following:

Lemma 3.10. *If $\alpha, \alpha', \beta', \beta \in \Omega^1(M)$ are any 1-forms such that their values at $x \in M$ satisfy $\alpha|_x = \alpha'|_x \in \text{Ker } \pi_x^\sharp$ and $\beta|_x = \beta'|_x \in \text{Ker } \pi_x^\sharp$, then*

$$[\alpha, \beta]_\pi|_x = [\alpha', \beta']_\pi|_x.$$

The proof uses the Leibniz identity for the bracket $[\cdot, \cdot]_\pi$ (see Proposition 2.11) and is left as an exercise.

Definition 3.11. The **isotropy Lie algebra** at x of a Poisson manifold (M, π) is the vector space $\text{Ker } \pi_x^\sharp$ equipped with the Lie bracket induced from $[\cdot, \cdot]_\pi$.

Next, we show that the isotropy Lie algebra depends only on the orbit.

Proposition 3.12. *The isotropy Lie algebras at different points on the same orbit of a Poisson manifold are isomorphic.*

Proof. If x and y belong to the same orbit of (M, π) , there is a Hamiltonian diffeomorphism ϕ that sends x to y . Since ϕ is a Poisson diffeomorphism, we have that $\phi_*\pi = \pi$ and

$$\phi^*[\alpha, \beta]_\pi = [\phi^*\alpha, \phi^*\beta]_\pi, \quad \forall \alpha, \beta \in \Omega^1(M).$$

It follows that $(d_x\phi)^*$ is a Lie algebra isomorphism from $\text{Ker } \pi_y^\sharp$ to $\text{Ker } \pi_x^\sharp$. \square

Exercise 3.13. Let x be a regular point of (M, π) . Show that the isotropy Lie algebra at x is abelian.

Hence, the isotropy Lie algebra is interesting only at singular points. We consider first one extreme case:

Example 3.14 (Zeros of Poisson structures). Let x be a point in a Poisson manifold (M, π) where π vanishes. In this case the isotropy Lie algebra has underlying vector space $\text{Ker } \pi_x^\sharp = T_x^*M$. Therefore, the dual space T_x^*M has a linear Poisson structure — see Subsection 2.4.6. This will be called the **linear approximation** to π at the zero x and will be denoted by π_x^{lin} .

Let us give the explicit local form of π_x^{lin} . In a chart (U, x^1, \dots, x^m) centered at x , we have

$$\pi|_U = \sum_{i < j} \pi^{ij} \frac{\partial}{\partial x^i} \wedge \frac{\partial}{\partial x^j}, \quad \text{with } \pi^{ij}(0) = 0.$$

The bracket on 1-forms is given by

$$[dx^i, dx^j]_\pi = d\{x^i, x^j\} = d\pi^{ij} = \sum_k \frac{\partial \pi^{ij}}{\partial x^k} dx^k.$$

Therefore, the structure constants for the Lie algebra structure of T_x^*M in the basis $\{dx^1, \dots, dx^m\}$ are given by the first-order partial derivatives of the bivector:

$$c_k^{ij} = \frac{\partial \pi^{ij}}{\partial x^k}(0).$$

The linear Poisson structure π_x^{lin} is then given in the corresponding linear coordinates on T_x^*M by

$$\pi_x^{\text{lin}} = \sum_{i < j} \left(\sum_k \frac{\partial \pi^{ij}}{\partial x^k}(0) x^k \right) \frac{\partial}{\partial x^i} \wedge \frac{\partial}{\partial x^j}.$$

Using Taylor's Theorem, the original Poisson structure takes the form

$$\pi|_U = \sum_{i < j} \left(\sum_k \frac{\partial \pi^{ij}}{\partial x^k}(0) x^k + O^{ij}(2) \right) \frac{\partial}{\partial x^i} \wedge \frac{\partial}{\partial x^j};$$

hence π_x^{lin} is indeed the *linear approximation* of π at x . 

At a point x where the rank is nonzero, the isotropy Lie algebra $\text{Ker } \pi_x^\sharp$ encodes the first-order approximation of π in the direction transverse to the orbit S through x . As we will see in the next chapter, S is an immersed submanifold of M satisfying $T_x S = \text{Im } \pi_x^\sharp$. Consider the **normal space** to S at x :

$$\nu_x(S) := T_x M / T_x S.$$

Note that if $\alpha \in \text{Ker } \pi_x^\sharp$, then by skew-symmetry

$$0 = \langle \pi_x^\sharp(\alpha), \beta \rangle = -\langle \alpha, \pi_x^\sharp(\beta) \rangle, \quad \forall \beta \in T_x^* M.$$

Therefore, $\text{Ker } \pi_x^\sharp$ consists of the covectors that annihilate $\text{Im } \pi_x^\sharp$:

$$\text{Ker } \pi_x^\sharp = \{ \alpha \in T_x^* M : \alpha|_{\text{Im } \pi_x^\sharp} = 0 \} = (\text{Im } \pi_x^\sharp)^\circ.$$

In other words, the isotropy Lie algebra at x can be identified with the **conormal space** to the orbit S at x , i.e., the dual of $\nu_x(S)$:

$$\text{Ker } \pi_x^\sharp = (\text{Im } \pi_x^\sharp)^\circ = (T_x S)^\circ = \nu_x^*(S).$$

The corresponding linear Poisson structure on the normal space $\nu_x(S)$ is called the **transverse linear approximation** of π at x and is denoted by $\pi_x^{\perp, \text{lin}}$. It can be identified with the linear approximation of the transverse component of π with respect to a Weinstein splitting chart. Namely, write

$$\pi|_U = \sum_{i=1}^s \frac{\partial}{\partial p_i} \wedge \frac{\partial}{\partial q^i} + \sum_{1 \leq a < b \leq q} \theta^{ab}(y) \frac{\partial}{\partial y^a} \wedge \frac{\partial}{\partial y^b},$$

with $\theta^{ab}(0) = 0$. The isotropy Lie algebra is the vector space

$$\text{Ker } \pi_x^\sharp = \langle d_x y^1, \dots, d_x y^q \rangle$$

with Lie bracket given by

$$[d_x y^a, d_x y^b] = [dy^a, dy^b]_\pi|_x = d_x \{y^a, y^b\} = d_0 \theta^{ab} = \sum_c \frac{\partial \theta^{ab}}{\partial y^c}(0) d_x y^c.$$

This shows that the isotropy Lie algebra of π at x coincides with the isotropy Lie algebra of $\theta = \sum_{a < b} \theta^{ab}(y) \frac{\partial}{\partial y^a} \wedge \frac{\partial}{\partial y^b}$ at 0. This implies the claim about the linear approximations:

$$\pi_x^{\perp, \text{lin}} = \sum_{a < b} \sum_c \frac{\partial \theta^{ab}}{\partial y^c}(0) y^c \frac{\partial}{\partial y^a} \wedge \frac{\partial}{\partial y^b}.$$

3.5. Linearization of Poisson structures

The Weinstein Splitting Theorem reduces the local study of Poisson manifolds to that of Poisson manifolds around a zero.

As we have seen in Example 3.14, at a zero x of π we obtain a linear Poisson manifold $(T_x M, \pi_x^{\text{lin}})$. It is natural to try to compare π with π_x^{lin} .

The Linearization Problem. Given a Poisson manifold (M, π) with a zero $x \in M$, is there a local Poisson diffeomorphism

$$\Phi : (M, \pi) \rightarrow (T_x M, \pi_x^{\text{lin}}) \quad \text{with} \quad \Phi(x) = 0?$$

If this happens, we say that π is **linearizable** at x .

Example 3.15. For $M = \mathbb{R}^2$ and

$$\pi = f \frac{\partial}{\partial x} \wedge \frac{\partial}{\partial y}, \quad \text{with} \quad f(0) = 0,$$

the linear approximation to π at the origin is

$$\pi_0^{\text{lin}} = \left(\frac{\partial f}{\partial x}(0)x + \frac{\partial f}{\partial y}(0)y \right) \frac{\partial}{\partial x} \wedge \frac{\partial}{\partial y},$$

and the isotropy Lie algebra is determined by the relation

$$[d_0 x, d_0 y] = d_0 f = \frac{\partial f}{\partial x}(0)d_0 x + \frac{\partial f}{\partial y}(0)d_0 y.$$

The isotropy Lie algebra is abelian if and only if $d_0 f = 0$. In this case, $\pi_0^{\text{lin}} = 0$, and so π can be linearized at 0 if and only if f vanishes on a neighborhood of 0. So there are many examples of nonlinearizable Poisson structures; for instance

$$\pi = (x^2 + y^2) \frac{\partial}{\partial x} \wedge \frac{\partial}{\partial y}.$$

The isotropy algebra is nonabelian if and only if $d_0 f \neq 0$. In this case, by Proposition 3.5, there are coordinates (u, v) centered at 0 which linearize π at 0:

$$\pi = u \frac{\partial}{\partial u} \wedge \frac{\partial}{\partial v}.$$

In particular, this also shows the basic fact that all nonabelian Lie algebras in dimension 2 are isomorphic. 

The previous example shows that in dimension 2 any Poisson structure vanishing at a point, and whose linear approximation does not vanish, can be linearized. However, this is rather unusual; most Poisson structures cannot be linearized around zeros, even if their linear approximation does not vanish.

Example 3.16. Consider a vector field $X \in \mathfrak{X}(\mathbb{R}^2)$ which is a cubic perturbation of the infinitesimal rotation vector field:

$$X = -y \frac{\partial}{\partial x} + x \frac{\partial}{\partial y} + (x^2 + y^2) \left(x \frac{\partial}{\partial x} + y \frac{\partial}{\partial y} \right).$$

We obtain a Poisson bivector field on \mathbb{R}^3 by setting

$$\pi = X \wedge \frac{\partial}{\partial z}.$$

The linear approximation of π at 0 is

$$\pi_0^{\text{lin}} = \left(-y \frac{\partial}{\partial x} + x \frac{\partial}{\partial y} \right) \wedge \frac{\partial}{\partial z}.$$

We leave it as an exercise to check the following:

- (a) The Poisson structure π has a line of zeros on the z -axis and the nearby orbits consist of surfaces spiraling around the z -axis.
- (b) The linear approximation π_0^{lin} has orbits the z -axis (zeros) and the cylinders around the z -axis.

Hence, there can be no local Poisson diffeomorphism defined around 0 mapping π_0^{lin} to π . We conclude that π is not linearizable at 0. 

In general, it is quite hard to obtain sufficient criteria for linearization. The following theorem is one of the most important linearization results in Poisson geometry:

Theorem 3.17 (Conn [35]). *Let (M, π) be a Poisson manifold with a zero $x \in M$. If the isotropy Lie algebra $\text{Ker } \pi_x^\sharp$ is semisimple and compact, then π is linearizable around x .*

The proof of Conn's Theorem is beyond the scope of this book. The assumption on the Lie algebra in the theorem admits several equivalent characterizations:

- \mathfrak{g} is semisimple and admits a compact Lie group integrating it;
- the simply connected Lie group integrating \mathfrak{g} is compact;
- any connected Lie group integrating \mathfrak{g} is compact;
- the Killing form of \mathfrak{g} is negative definite.

For example, the Lie algebras $\mathfrak{so}(n, \mathbb{R})$ ($n \geq 3$) and $\mathfrak{su}(n)$ ($n \geq 2$) satisfy these conditions. For most semisimple Lie algebras that are not compact, it is known that a version of Conn's Theorem does not hold [150]. For example, in Problem 3.9 below you are asked to show that a certain Poisson structure with the isotropy Lie algebra $\mathfrak{sl}(2, \mathbb{R})$ at a zero is not linearizable. Remarkably, for certain semisimple Lie algebras this problem is still open.

A survey of these results can be found in the monograph by Dufour and Zung [59]. This book includes also several other deep linearization and local normal form results by Dufour, Monnier, and Zung, e.g., a Levi-type decomposition for Poisson structures around zeros.

Problems

3.1. Let $\pi \in \mathfrak{X}^2(M)$ be a bivector field. Show that $x \mapsto \text{rank } \pi_x$ is a lower semicontinuous function: every $x \in M$ has a neighborhood U such that

$$\text{rank } \pi_x \leq \text{rank } \pi_y, \quad \forall y \in U.$$

3.2. Prove Lemma 3.10 using the Leibniz identity for $[\cdot, \cdot]_\pi$.

3.3. Let \mathfrak{g} be a Lie algebra. Show that the isotropy Lie algebra of the linear Poisson structure $(\mathfrak{g}^*, \pi_{\mathfrak{g}})$ at $\xi \in \mathfrak{g}^*$ coincides with the isotropy of the coadjoint action:

$$\mathfrak{g}_\xi = \{v \in \mathfrak{g} : \xi([v, w]) = 0, \forall w \in \mathfrak{g}\}.$$

3.4. Show that the isotropy Lie algebra of a Poisson structure of Lotka-Volterra type from Example 1.28 at any point is abelian.

3.5. On a 3-dimensional manifold M , consider a volume form $\mu \in \Omega^3(M)$ and a smooth function $C \in C^\infty(M)$. Let π be the Poisson structure corresponding to μ and the exact 1-form $\theta = dC$, as constructed in Subsection 2.4.4.

- (a) Show that $x \in M$ is a critical point of C if and only if x is a zero of π .
- (b) Show that $x \in M$ is a nondegenerate critical point of C (i.e., the Hessian of C at x is nondegenerate) if and only if the isotropy Lie algebra of π at x is isomorphic to either $\mathfrak{so}(3, \mathbb{R})$ or $\mathfrak{sl}(2, \mathbb{R})$.

REMARK: In this case, it can be shown that π is linearizable around x .

3.6. Consider the Poisson structures in \mathbb{R}^2 given by

$$\pi = a(u^2 \pm v^2) \frac{\partial}{\partial u} \wedge \frac{\partial}{\partial v},$$

where $a > 0$ is some positive real number.

- (a) Show that their isotropy Lie algebras at the origin are abelian.
- (b) Show that for different values of $a > 0$ these Poisson structures are not isomorphic in any neighborhood of the origin.

3.7. Consider the Poisson structure of Example 3.16:

$$\pi = X \wedge \frac{\partial}{\partial z}, \quad X = -y \frac{\partial}{\partial x} + x \frac{\partial}{\partial y} + (x^2 + y^2) \left(x \frac{\partial}{\partial x} + y \frac{\partial}{\partial y} \right).$$

- (a) Show that, in polar coordinates, $X = \frac{\partial}{\partial \theta} + r^3 \frac{\partial}{\partial r}$, so $r^{-2} + 2\theta$ is locally constant along its flow lines.
- (b) Show that the z -axis is a line of zeros of π and that the nearby orbits consist of surfaces spiraling around the z -axis.
HINT: Show that the orbits of π are obtained by translating the orbits of the vector field X in the direction of the z -axis.
- (c) Show that the linear approximation to π at 0 is

$$\pi_0^{\text{lin}} = \left(-y \frac{\partial}{\partial x} + x \frac{\partial}{\partial y} \right) \wedge \frac{\partial}{\partial z} = \frac{\partial}{\partial \theta} \wedge \frac{\partial}{\partial z}.$$

- (d) Verify that π_0^{lin} vanishes along the z -axis and that the other orbits are cylinders around the z -axis.
- (e) Conclude that π is not linearizable at the origin.

3.8. Construct examples of bivector fields π on \mathbb{R}^4 satisfying:

- (a) π is nondegenerate, but does not admit Weinstein splitting coordinates anywhere;
- (b) π has constant rank = 2, but does not admit Weinstein splitting coordinates anywhere;
- (c) $\pi \wedge \pi$ is transverse to the zero section of $\wedge^4 T\mathbb{R}^4$, and π is not tangent to the singular locus $Z := (\pi \wedge \pi)^{-1}(0)$.

3.9. We use the identification $\mathfrak{sl}(2, \mathbb{R})^* \simeq \mathbb{R}^3$ from Problem 1.10 and consider the linear Poisson structure $\pi_{\mathfrak{sl}(2, \mathbb{R})}$.

- (a) Show that in cylindrical coordinates $x = r \cos(\theta)$, $y = r \sin(\theta)$, $z = z$

$$\pi_{\mathfrak{sl}(2, \mathbb{R})} = 2 \left(\frac{\partial}{\partial z} + \frac{z}{r} \frac{\partial}{\partial r} \right) \wedge \frac{\partial}{\partial \theta}.$$

- (b) Let $\chi : \mathbb{R} \rightarrow [0, \infty)$ be a smooth function satisfying

$$\chi(t) = \begin{cases} 0, & \text{for } t \leq 0, \\ > 0, & \text{for } t > 0. \end{cases}$$

(e.g., take $\chi(t) = e^{-1/t}$, for $t > 0$). Prove that the function $\epsilon : \mathbb{R}^3 \rightarrow \mathbb{R}$, given in cylindrical coordinates by $\epsilon(r, \theta, z) = \chi(r^2 - z^2)/r^2$, is smooth.

(c) Show that

$$\pi := \pi_{\mathfrak{sl}(2, \mathbb{R})} + \epsilon(r, \theta, z) r \frac{\partial}{\partial r} \wedge \frac{\partial}{\partial z}$$

is a Poisson structure which vanishes at 0 and has isotropy Lie algebra $\mathfrak{sl}(2, \mathbb{R})$.

(d) Prove that π is not linearizable at 0.

Notes and References for Part 1

In the period 1808–1810, five papers were published by the French mathematicians Siméon Denis Poisson (1781–1840) and Joseph-Louis Lagrange (1736–1813), each paper improving on the preceding ones. These works were concerned with both concrete problems in rational mechanics, such as the motion of the planets in the solar system, and the general mathematical formulation of mechanics. While Poisson created his bracket, a special case of the general bracket introduced in the first chapter, Lagrange created another bracket, called the Lagrange bracket, which can be interpreted as the components of a symplectic form. An account of the inception of Poisson and symplectic geometry and how they are interlaced can be found in the article by Marle [116]. A survey of the mathematical contributions of Poisson can be found in the collection [102]. For a historical account of how Poisson brackets influenced the development of Lie theory see the works of Hawkins [86, 87].

The foundations of modern day Poisson geometry, as presented in these lectures, is usually credited to Kirillov [98], Lichnerowicz [109], and Weinstein [147]. While Kirillov worked with a Lie bracket on the space of functions, Lichnerowicz was the first one to introduce the calculus of multivector fields and to recognize its relevance to Poisson geometry. He was also the one who realized the relevance of the Schouten bracket, sometimes called the Schouten-Nijenhuis bracket, which had been introduced by Schouten [135] and Nijenhuis [127] in connection with other questions in differential geometry. Lichnerowicz in [109] used the Schouten bracket to define the Poisson cohomology that we will study in a later chapter.

The article by Weinstein [147] is arguably the most important of these earlier works, and its influence has lasted to the present. He established the Weinstein Splitting Theorem, introduced the isotropy Lie algebra, formulated the linearization problem, obtained formal linearization results, and proposed several conjectures. The analytic and smooth linearization results were soon after proved by Conn [35], using analytic methods, and the search for geometric arguments led to further development of Poisson geometry. In the same paper, Weinstein also introduced many other basic notions for Poisson manifolds, such as the notion of symplectic realization, that we will study in later chapters.

The article [101] by Kosmann-Schwarzbach contains a detailed historical account of Poisson geometry ranging from the early contributions of Lagrange, Poisson, Hamilton, and Liouville to the early days of modern Poisson geometry. The survey article by Weinstein [156] describes the state of the field at the end of the 1990s.

Our presentation of the basic elements of Poisson geometry is standard and follows Weinstein's original paper closely. Chapter 3 even has the same title as [147], in homage to this work. Perhaps, the only nonstandard term used in this first part of the text is the designation "LV-type Poisson structure", which is often called a "log-canonical Poisson structure". We have decided not to use the latter term in order to avoid confusion with the notion of log-symplectic Poisson structure and because it seems to be historically accurate — see [57, 131].

Our choice of examples of Poisson structures illustrating the theory is mainly motivated by pedagogical reasons. Some of these classes have a wide range of applications and connections with other fields, for example, going beyond symplectic structures, linear Poisson structures in Lie theory [4, 8], log-symplectic structures in Melrose's b-geometry [82, 84, 126], or LV-type Poisson structures in the theory of cluster algebras [69, 74]. There are many other examples of Poisson structures which appear naturally in various settings. Just to list a few, one finds Poisson structures on various moduli spaces [6, 16], on semiclassical versions of quantum groups [56, 100], on algebraic groups and Bott-Samelson varieties [70, 111, 112], in derived algebraic geometry [26, 130], etc. These were left out since each of them would require a detour to discuss them properly.

Part 2

Poisson Geometry Around Leaves

One of the most important aspect of a Poisson manifold is that it is built out of symplectic leaves that fill up the manifold in a nice way. We have seen this before in special cases, where we call these leaves “orbits” of the Poisson manifold. Now we will see that they are actually immersed submanifolds carrying a symplectic structure, and locally they can always be seen as “plaques”, justifying the name symplectic foliation. Globally, they can be entangled and form a very complicated partition of the manifold.

Symplectic Leaves and the Symplectic Foliation

4.1. The symplectic foliation

The orbits of a Poisson manifold (M, π) , which were introduced in Section 1.2, have a natural smooth structure. The charts are constructed using Weinstein splitting charts. The orbits become maximal integral submanifolds of the singular distribution $\text{Im } \pi^\sharp$. They also carry natural symplectic structures — therefore justifying the terminology *symplectic leaves*.

Theorem 4.1. *An orbit S of a Poisson manifold (M, π) has a unique smooth structure for which the inclusion is an immersion. The tangent spaces of S consist of the Hamiltonian directions*

$$T_x S = \text{Im } \pi_x^\sharp, \quad \forall x \in S,$$

and S has a symplectic structure ω_S defined at $x \in S$ by

$$(4.1) \quad \omega_S(\pi_x^\sharp \alpha, \pi_x^\sharp \beta) = -\pi_x(\alpha, \beta), \quad \forall \alpha, \beta \in T_x^* M.$$

For the proof we fix an orbit S and denote $2s := \text{rank}(\pi|_S)$. This number is indeed well-defined, since by Proposition 3.12 we have:

Lemma 4.2. *The rank of π is constant along orbits.*

Consider a connected Weinstein splitting chart (U, χ) around a point in S , i.e., a Poisson diffeomorphism

$$\chi : (U, \pi|_U) \xrightarrow{\simeq} (V, \pi_{\text{can}}|_V) \times (W, \theta)$$

where $V \subset \mathbb{R}^{2s}$ and $W \subset \mathbb{R}^q$ are open and θ is a Poisson structure on W .

Lemma 4.3. *For some subset $\Lambda \subset \{w \in W : \theta_w = 0\}$, we have that*

$$S \cap U = \chi^{-1}(V \times \Lambda).$$

Moreover, if an integral curve of a Hamiltonian vector field lies in $S \cap U$, then it lies in $\chi^{-1}(V \times \{\lambda\})$, for a unique $\lambda \in \Lambda$.

Proof. For $(v, \lambda) \in \chi(S \cap U)$, we need to show that $(v', \lambda) \in \chi(S \cap U)$ for any $v' \in V$. For this we will move from one point to the other by Hamiltonian diffeomorphisms.

Assume first that the line segment $[v, v']$ belongs to V . For the standard symplectic structure on \mathbb{R}^{2s} , the constant vector field $v' - v$ is the Hamiltonian vector field of a linear function $a \in (\mathbb{R}^{2s})^*$. Let H be a compactly supported smooth function on $V \times W$ such that $H(u, w) = a(u)$, for (u, w) in a neighborhood of $[v, v'] \times \{\lambda\}$. Then

$$\phi_{X_H}^t(v, \lambda) = (v + t(v' - v), \lambda).$$

Since χ is a Poisson map, $\phi_{X_H \circ \chi}^1$ sends $\chi^{-1}(v, \lambda)$ to $\chi^{-1}(v', \lambda)$, so we conclude that $(v', \lambda) \in \chi(S \cap U)$.

In general, since V is connected and open, for any $v' \in V$ we can find a sequence $v_0 = v, v_1, \dots, v_k = v'$ with $[v_i, v_{i+1}] \subset V$. By applying the above argument to each segment, we obtain that $(v', \lambda) \in \chi(S \cap U)$, as claimed.

This proves that $\chi(S \cap U) = V \times \Lambda$ for some $\Lambda \subset W$. Since $\text{rank}(\pi|_S) = 2s$ and $\text{rank}(\pi_{\text{can}}|_v + \theta|_w) = 2s + \text{rank}(\theta|_w)$, we have that

$$\Lambda \subset \{w \in W : \theta_w = 0\}.$$

So if $(v_t, \lambda_t) \in V \times \Lambda$ is an integral curve of a Hamiltonian vector field X_H , then

$$\frac{d}{dt} \lambda_t = \theta_{\lambda_t}^\#(d_{(v_t, \lambda_t)} H) = 0,$$

and so λ_t is constant. This proves the second part. \square

Let $\{(U_i, \chi_i)\}_{i \in I}$ be an open cover of S by connected splitting charts centered at points in S . Write $\chi_i(S \cap U_i) = V_i \times \Lambda_i$ and for $\lambda \in \Lambda_i$ set

$$U_{(i, \lambda)} := \chi_i^{-1}(V_i \times \{\lambda\}) \subset S \cap U_i.$$

Note that each $U_{(i, \lambda)}$ is a $2s$ -dimensional embedded submanifold of M . We should think of these submanifolds as the *plaques* for the Weinstein splitting charts — compare with the discussion following Theorem C.4. The manifold structure of S is constructed such that the inclusions

$$U_{(i, \lambda)} \hookrightarrow S$$

are smooth open embeddings. For this to work, the sets $U_{(i,\lambda)}$ must have open intersections:

Lemma 4.4. $U_{(i,\lambda)} \cap U_{(j,\mu)}$ is open in $U_{(i,\lambda)}$.

Proof. Let $x \in U_{(i,\lambda)} \cap U_{(j,\mu)}$. The intersection $U_{(i,\lambda)} \cap U_j$ is open in $U_{(i,\lambda)}$, and therefore it is a union of open connected components. If C is the component containing x , then, as in the proof of Lemma 4.3, any two points in C can be connected by Hamiltonian flow lines in C . Since $C \subset S \cap U_j$, Lemma 4.3 implies that $C \subset U_{(j,\mu)}$. Thus $C \subset U_{(i,\lambda)} \cap U_{(j,\mu)}$. Since x was arbitrary, we conclude that $U_{(i,\lambda)} \cap U_{(j,\mu)}$ is open in $U_{(i,\lambda)}$. \square

The existence of a smooth structure for S is now implied by the following general result:

Lemma 4.5. Let $\{N_i\}_{i \in I}$ be a collection of embedded submanifolds of M , all of the same dimension. Assume that for all $i, j \in I$, $N_i \cap N_j$ is open in N_i . Then $N := \bigcup_{i \in I} N_i$ is a smooth manifold, possibly not second countable, for which the inclusion $N \hookrightarrow M$ is an immersion. The differential structure is uniquely determined by the condition that the maps $N_i \hookrightarrow N$ are smooth open embeddings.

Proof. Consider the topology on N generated by open subsets of N_i , with $i \in I$. Then the inclusion $N \hookrightarrow M$ is continuous and, in particular, N is Hausdorff. The assumption that the intersection $N_i \cap N_j$ is open in N_i , for all $j \in I$, implies that the inclusion $N_i \hookrightarrow N$ is an open embedding.

Fix a smooth atlas \mathcal{A}_i on each N_i , and let

$$\mathcal{A} := \bigcup_{i \in I} \mathcal{A}_i.$$

We claim that \mathcal{A} is an atlas for N . Clearly, the elements of \mathcal{A} are still charts on N , i.e., homeomorphisms onto their image. Let $(U_i, \chi_i) \in \mathcal{A}_i$ and $(U_j, \chi_j) \in \mathcal{A}_j$ be two charts in \mathcal{A} . Since U_j is an embedded submanifold of M , $\chi_j : U_j \rightarrow \mathbb{R}^k$ has a smooth extension $\tilde{\chi}_j : O \rightarrow \mathbb{R}^k$ to some open set $O \supset U_j$ of M . On $\chi_i(U_i \cap U_j)$ we can write $\chi_j \circ \chi_i^{-1} = \tilde{\chi}_j \circ \chi_i^{-1}$, which shows that the transition function is smooth. Hence, \mathcal{A} is a smooth atlas on N .

Finally, the condition that the maps $N_i \hookrightarrow N$ be smooth open embeddings determines the set $C^\infty(N)$, which further determines the differential structure on N . \square

That the orbits are second countable is implied by the general result: any connected immersed submanifold of a second countable manifold is second countable (see [137, Appendix A]). Here is a direct argument:

Lemma 4.6. The orbit S is second countable.

Proof. Since M is second countable, there is a countable subset $K \subset I$ such that $\bigcup_{k \in K} U_k = \bigcup_{i \in I} U_i$. Let

$$\mathcal{V} := \{(k, \lambda) : k \in K, \lambda \in \Lambda_k\}.$$

Since $S = \bigcup_{(k, \lambda) \in \mathcal{V}} U_{(k, \lambda)}$, it suffices to check that \mathcal{V} is a countable set.

As noted in the proof of Lemma 4.4, each connected component of $U_{(k, \lambda)} \cap U_l$ is contained in a unique $U_{(l, \mu)}$; clearly, the number of such connected components is at most countable. Since K is countable, it follows that for each $(k, \lambda) \in \mathcal{V}$ there are at most a countable number of $(l, \mu) \in \mathcal{V}$ such that $U_{(k, \lambda)} \cap U_{(l, \mu)} \neq \emptyset$. We conclude that, for a fixed $(k_0, \lambda_0) \in \mathcal{V}$, the set of all finite sequences

$$(k_1, \lambda_1), \dots, (k_m, \lambda_m) \in \mathcal{V}, \quad \text{s.t. } U_{(k_{i-1}, \lambda_{i-1})} \cap U_{(k_i, \lambda_i)} \neq \emptyset \quad (1 \leq i \leq m)$$

is at most countable.

We claim that every $(l, \mu) \in \mathcal{V}$ is the end point of a sequence, proving that \mathcal{V} is countable. For this, fix points $x \in U_{(k_0, \lambda_0)}$ and $y \in U_{(l, \mu)}$, and consider a Hamiltonian flow line γ from x to y . By compactness of $\gamma([0, 1])$, there are

$$k_1, \dots, k_m = l \in K \quad \text{and} \quad t_0 = 0 < t_1 < \dots < t_{m+1} = 1$$

such that $\gamma([t_i, t_{i+1}]) \subset U_{k_i}$. By Lemma 4.3, there are unique indexes

$$\lambda_1 \in \Lambda_{k_1}, \dots, \lambda_{m-1} \in \Lambda_{k_{m-1}}, \lambda_m = \mu \in \Lambda_l$$

such that $\gamma([t_i, t_{i+1}]) \subset U_{(k_i, \lambda_i)}$. Hence, $\gamma(t_i) \in U_{(k_{i-1}, \lambda_{i-1})} \cap U_{(k_i, \lambda_i)}$. \square

Next, we show that the smooth structure on the orbits is unique, by showing that the orbits are initial submanifolds — see Definition C.8 and Theorem C.11.

Lemma 4.7. *The orbit S is an initial submanifold. Therefore, S admits a unique differential structure for which the inclusion is an immersion.*

Proof. Let $f : P \rightarrow M$ be a smooth map such that $f(P) \subset S$. We need to show that f is smooth when viewed as a map to S . Since smoothness is a local property, we may assume that P is connected and that there is a splitting chart $\chi : U \xrightarrow{\sim} V \times W$ such that $f(P) \subset S \cap U$. Denote $\chi(S \cap U) = V \times \Lambda$. Then $\text{pr}_W \circ \chi \circ f(P)$ is a path-connected subset of Λ , and since Λ is at most countable (Lemma 4.6), it follows that $\text{pr}_W \circ \chi \circ f(P)$ consists of a single point $\lambda \in \Lambda$. Thus $f(P)$ maps into the plaque $U_\lambda := \chi^{-1}(V \times \{\lambda\})$. Since U_λ is an embedded submanifold of M , it follows that $f : P \rightarrow U_\lambda$ is smooth. Since the inclusion $U_\lambda \hookrightarrow S$ is smooth, so is $f : P \rightarrow S$. \square

Proof of Theorem 4.1. Lemmas 4.5, 4.6, and 4.7 show that every orbit S has a unique smooth structure for which it is an immersed submanifold.

Next, fix $x \in S$ and a splitting chart centered at x

$$\chi : (U, \pi|_U) \xrightarrow{\sim} (V, \pi_{\text{can}}|_V) \times (W, \theta), \quad \chi(x) = (0, 0), \quad \theta_0 = 0.$$

This yields a chart (U_0, χ_0) on S centered at x :

$$U_0 := \chi^{-1}(V \times \{0\}), \quad \chi_0 := \text{pr}_V \circ \chi|_{U_0}.$$

Next, since π_{can} is nondegenerate and $\theta_0 = 0$, we have that

$$T_{(0,0)}(V \times \{0\}) = \text{Im}(\pi_{\text{can},0} + \theta_0)^\sharp.$$

Via the Poisson map χ^{-1} , this yields the description of the tangent space:

$$T_x S = T_x U_0 = \text{Im } \pi_x^\sharp.$$

It is now clear that (4.1) defines a 2-form on S . Since in the chart (U_0, χ_0)

$$\omega_S|_{U_0} = \chi_0^*(\omega_{\text{can}}),$$

we see that ω_S is indeed a symplectic structure on S . \square

Theorem 4.1 implies that the orbits together with their symplectic forms determine the Poisson structure. Namely, if (S, ω_S) is the orbit through a point x , then the Poisson structure at x is given by

$$\pi_x = \omega_{S,x}^{-1} \in \bigwedge^2 T_x S \subset \bigwedge^2 T_x M.$$

In particular, we deduce:

Corollary 4.8. *The symplectic structure on the orbit S of (M, π) is the unique symplectic structure ω_S for which the inclusion*

$$(S, \omega_S^{-1}) \hookrightarrow (M, \pi)$$

is a Poisson map.

We conclude that a Poisson structure can be viewed as a partition of the manifold into disjoint submanifolds endowed with symplectic structures.

Definition 4.9. A **symplectic leaf** of a Poisson manifold (M, π) is an orbit S together with the induced symplectic form ω_S . The **symplectic foliation** of (M, π) is the collection of symplectic leaves:

$$\mathcal{F}_\pi = \{(S, \omega_S) : S \text{ is a symplectic leaf}\}.$$

Remark 4.10. We emphasize that we use the term “symplectic foliation” in Definition 4.9 as synonymous with “the collection of all orbits/leaves of (M, π) ”. In general, these leaves have different dimension and they do not form a (regular) symplectic foliation. It is possible to make sense of the notion of *singular foliation* and one can indeed associate to the singular distribution $\text{Im } \pi^\sharp$ a singular foliation — see Section C.3. However, to define

the notion of *singular symplectic foliation* one would need to make sense of the notion of foliated form in the singular setting. Still, one can view (4.1) as saying that the symplectic forms on the leaves assemble into a global smooth object: the Poisson structure. In some sense, a singular symplectic foliation is a Poisson structure!

We shall not make any use of the theory of singular foliations. Still it is sometimes helpful to keep them in mind. For example, the following useful alternative characterization of symplectic leaves can be viewed as saying that they are the maximal integral submanifolds of the singular distribution $\text{Im } \pi^\sharp$:

Proposition 4.11. *Let (M, π) be a Poisson manifold, and let $i : N \hookrightarrow M$ be a connected immersed submanifold, satisfying*

$$T_x N = \text{Im } \pi_x^\sharp, \quad \forall x \in N.$$

Then N is an open subset of a single symplectic leaf.

Proof. Since N is connected, it is enough to prove the result locally. Therefore, assume that N is contained in the domain of a connected Weinstein splitting chart centered at a point of N :

$$\chi : (U, \pi|_U) \xrightarrow{\simeq} (V, \pi_{\text{can}}|_V) \times (W, \theta).$$

Since $\dim N = \dim V$ and $\text{rank } \pi|_N = \dim N$, we have that $\chi(N) \subset V \times Z$, where Z is the zero set of θ . Since χ is a Poisson diffeomorphism, we obtain

$$d\chi(TN) = d\chi(\text{Im } \pi^\sharp|_N) = \text{Im}(\pi_{\text{can}}|_V + \theta|_Z)^\sharp = TV \times Z.$$

Hence, $d(\text{pr}_W \circ \chi)(TN) = 0$, and so $\text{pr}_W \circ \chi$ is constant on N . This implies that $N \subset \chi^{-1}(V \times \{\lambda\})$, for some $\lambda \in W$. Thus, by Lemma 4.3, N is contained in a single symplectic leaf S . Since S is an initial submanifold, the inclusion map $i : N \hookrightarrow S$ is smooth. Since i is an immersion between manifolds of the same dimension, it is a local diffeomorphism. We conclude that N is an open subset of S . \square

Proposition 4.11 immediately implies the criterion used in Chapter 1 to prove that a given partition is indeed the symplectic foliation of a Poisson manifold:

Proof of Proposition 1.8. By Proposition 4.11, each element of $N \in \mathcal{S}$ is an open subset of a unique symplectic leaf $S \in \mathcal{F}_\pi$. The elements of \mathcal{S} contained in a fixed leaf $S \in \mathcal{F}_\pi$ form an open cover of S by disjoint subsets. Since S is connected, there is only one $N \in \mathcal{S}$ included in S , and so one must have $N = S$. \square

Finally, we prove that the symplectic leaves of a Poisson manifold coincide with the orbits of the Hamiltonian group:

Proof of Proposition 1.14. By its definition, note that a symplectic leaf is contained in an orbit of the action of the Hamiltonian group $\text{Ham}(M, \pi)$: if $x \sim y$ are two points in the same leaf, then $y = \phi(x)$ where ϕ is a composition of Hamiltonian diffeomorphisms.

For the reverse inclusion, observe that if two points x and y belong to the same orbit of the action of the Hamiltonian group $\text{Ham}(M, \pi)$, then they are connected by an integral curve $\gamma : [0, 1] \rightarrow M$ of a time-dependent Hamiltonian vector field X_{H_t} . Say that some $\gamma(t_0)$ belongs to some leaf S , for some $t_0 \in [0, 1]$. Because the inclusion of the leaf is a Poisson map, we have that the integral curve through t_0 of the restricted Hamiltonian function $H_t|_S$ is also an integral curve of X_{H_t} . Hence $\gamma(t) \in S$, for all $t \in (t_0 - \varepsilon, t_0 + \varepsilon)$, for some $\varepsilon > 0$. Since $[0, 1]$ is connected, it follows that $\gamma(t)$ stays in the same leaf for all $t \in [0, 1]$. Hence, $x, y \in S$ and the result follows. \square

4.2. Regular Poisson structures

Definition 4.12. A Poisson manifold (M, π) is called **regular** if the rank of π is constant.

For a regular Poisson manifold (M, π) , we have that $\text{Im } \pi^\sharp \subset TM$ is a smooth subbundle; i.e., it is a distribution, which is involutive by Proposition 2.11. Therefore it defines a (regular) foliation \mathcal{F}_π of M with

$$(4.2) \quad T\mathcal{F}_\pi = \text{Im } \pi^\sharp.$$

It follows, e.g., from Proposition 4.11, that the leaves of this foliation are the symplectic leaves of π . The symplectic structures from Theorem 4.1 glue to a foliated 2-form on \mathcal{F}_π

$$\omega_{\mathcal{F}_\pi} \in \Omega^2(\mathcal{F}_\pi) = \Gamma\left(\bigwedge^2 T^*\mathcal{F}_\pi\right),$$

given by

$$(4.3) \quad \omega_{\mathcal{F}_\pi}(\pi^\sharp(\alpha), \pi^\sharp(\beta)) = -\pi(\alpha, \beta).$$

This is of course related to Subsection 2.4.3 and in fact we have:

Theorem 4.13. *Formulas (4.2) and (4.3) establish a 1-to-1 correspondence*

$$\left\{ \begin{array}{l} \text{regular Poisson} \\ \text{structures } \pi \in \mathfrak{X}^2(M) \end{array} \right\} \xleftrightarrow{\sim} \left\{ \begin{array}{l} \text{symplectic foliations} \\ (\mathcal{F}, \omega_{\mathcal{F}}) \text{ on } M \end{array} \right\}.$$

Proof. Given a symplectic foliation $(\mathcal{F}, \omega_{\mathcal{F}})$ we have seen in Subsection 2.4.3 how to obtain a Poisson structure π which satisfies (4.2) and (4.3).

For the converse, the above construction gives a foliated form $\omega_{\mathcal{F}_\pi}$ and we are left to check that it is a foliated nondegenerate, closed 2-form, in the sense of Definition C.14. The nondegeneracy follows immediately from the fact that $T\mathcal{F}_\pi = \text{Im } \pi^\sharp$. That it is closed follows because $d_{\mathcal{F}}$ is the leafwise de Rham differential, and the restriction of $\omega_{\mathcal{F}_\pi}$ to the leaf S is the symplectic structure ω_S . Alternatively, one can prove it using the explicit formula

$$d_{\mathcal{F}}\omega_{\mathcal{F}_\pi}(\pi^\sharp(\alpha), \pi^\sharp(\beta), \pi^\sharp(\gamma)) = -[\pi, \pi](\alpha, \beta, \gamma), \quad \forall \alpha, \beta, \gamma \in T^*M,$$

which we leave as an exercise (see Problem 4.5). □

In order to obtain a regular Poisson structure on a given manifold M , we need to construct a foliation together with a leafwise symplectic form. For instance, in dimension 3, it is known that any compact manifold M admits a codimension-1 foliation \mathcal{F} . If the foliation is oriented, a Riemannian metric on M induces a leafwise volume form ω . Since the leaves are 2-dimensional, ω makes \mathcal{F} into a symplectic foliation.

Example 4.14 (Symplectic foliation of Kronecker type). Inspired by the Kronecker foliation of the 2-torus \mathbb{T}^2 — see Example C.7 — we consider the foliation on \mathbb{T}^3 induced by the nowhere vanishing closed 1-form

$$\theta_\lambda = d\phi^1 + \lambda d\phi^2 \quad (\lambda \in \mathbb{R})$$

where (ϕ^1, ϕ^2, ϕ^3) are the angle coordinates. Depending on λ being rational or irrational, the leaves are either all 2-tori or all cylinders. Choosing any metric on \mathbb{T}^3 and the standard volume form, we obtain our main examples of symplectic foliations of the 3-torus. 

Example 4.15 (Reeb foliation). A famous foliation of a foliation on \mathbb{S}^3 is obtained by decomposing \mathbb{S}^3 as a union of two solid tori glued along their boundaries, and each solid torus is foliated by disks that wind asymptotically towards the boundary as in Figure 4.1. This is known as the **Reeb foliation** and it played a crucial role in the development of foliation theory. For a more detailed description, see [122, Example 1.1(5)]. You should try to construct an explicit Poisson structure π on \mathbb{S}^3 whose symplectic foliation is the Reeb foliation. 

Given a foliation \mathcal{F} of a manifold M we can try to look for a closed 2-form on M which restricts to a nondegenerate 2-form on the leaves. This rarely works: for example, if $H^2(M) = 0$ and \mathcal{F} has a compact leaf, this is

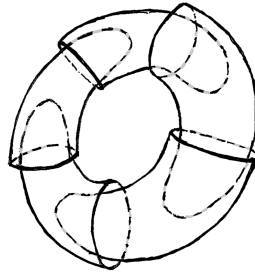

Figure 4.1. The Reeb foliation of a solid torus.

not possible, as in the Reeb foliation. In fact, we have the following famous result:

Theorem 4.16 (Novikov). *On a compact 3-manifold with finite fundamental group every codimension-1 foliation admits a compact leaf.*

See, e.g., [122] for a proof. On the other hand, given a symplectic foliation of M , one can always extend the foliated symplectic form to a global 2-form on M (see the problems at the end of this chapter). So given a foliation, a natural question is to look for a 2-form that restricts to a symplectic form on the leaves.

Example 4.17 (Cosymplectic structures). Let M^{2n+1} be an odd-dimensional manifold, and let us look for codimension-1 symplectic foliations. As we have already mentioned, a simple way of obtaining such a foliation \mathcal{F} is to start with a nowhere vanishing closed 1-form $\theta \in \Omega^1(M)$. If we now look for a closed 2-form ω on M which restricts to a nondegenerate 2-form on the leaves, we discover the condition in the following definition:

Definition 4.18. A **cosymplectic structure** on an odd-dimensional manifold M^{2n+1} is a pair $(\theta, \omega) \in \Omega^1(M) \times \Omega^2(M)$ satisfying

$$d\theta = 0, \quad d\omega = 0, \quad \theta \wedge \omega^n \text{ is a volume form.}$$

How can one recognize the regular Poisson structures that arise from such structures? The key to answering this question is the notion of **Reeb vector field** of the pair (θ, ω) , which is the unique vector field $X \in \mathfrak{X}(M)$ satisfying

$$\theta(X) = 1, \quad i_X \omega = 0.$$

This vector field is clearly transverse to the foliation and it turns out to be a Poisson vector field. In fact, we obtain:

Proposition 4.19. *For an odd-dimensional manifold M there is a 1-to-1 correspondence*

$$\left\{ \begin{array}{l} \text{corank 1 Poisson structures } \pi \\ \text{with a Poisson vector field } X \pitchfork \mathcal{F}_\pi \end{array} \right\} \xleftrightarrow{\sim} \left\{ \begin{array}{l} \text{cosymplectic structures} \\ (\theta, \omega) \text{ on } M \end{array} \right\}.$$

Proof. Given a cosymplectic structure (θ, ω) , to check that the corresponding Reeb vector field is Poisson, we observe that its defining equations imply

$$\mathcal{L}_X \theta = \mathcal{L}_X \omega = 0.$$

Hence, the flow of X preserves both θ and ω , and so it preserves the corresponding Poisson bivector π . Conversely, given π together with a Poisson vector field X transverse to the symplectic foliation \mathcal{F}_π we have

$$TM = T\mathcal{F}_\pi \oplus \langle X \rangle,$$

so we can define a 1-form θ by

$$i_X \theta = 1, \quad \theta|_{T\mathcal{F}_\pi} = 0,$$

and a 2-form ω by

$$i_X \omega = 0, \quad \omega|_{T\mathcal{F}_\pi} = \omega_{\mathcal{F}_\pi}.$$

We leave as a simple exercise the check that (θ, ω) is a cosymplectic structure and that these two constructions are inverse to each other. \square



In general, the existence of foliations on a given manifold is a classical problem in foliation theory, which is well understood in codimension 1. On the other hand, the existence of a leafwise symplectic form on a given foliation is a much more subtle problem as it is a parametric version of the problem of existence of symplectic forms — see [14]. For example, every odd-dimensional sphere admits a codimension-1 foliation, but only \mathbb{S}^1 , \mathbb{S}^3 , and \mathbb{S}^5 are known to admit a regular Poisson structure of codimension 1: for \mathbb{S}^1 it is trivial, \mathbb{S}^3 admits the Reeb foliation, while for \mathbb{S}^5 it is far from being trivial — see [121].

In contrast, it is known that if a noncompact connected manifold M admits a $2s$ -dimensional foliation with a leafwise nondegenerate 2-form, then it also admits a regular Poisson structure of rank $2s$ — see [67]. This generalizes a classical result of Gromov on the existence of symplectic structures on open manifolds — see [118].

4.3. More examples of symplectic foliations

Example 4.20 (Log-symplectic structures). Consider a log-symplectic Poisson structure (M^{2n}, π) , with singular locus Z — recall Example 3.6.

There are two types of symplectic leaves of (M, π) . First there are the open leaves, which are the connected components of

$$(M \setminus Z, \eta), \quad \eta^b := (\pi^\sharp|_{M \setminus Z})^{-1}.$$

The second type of leaves are all included in Z , and they can be described as follows:

Proposition 4.21. *The symplectic leaves of π that are included in Z are given by a cosymplectic structure (θ, ω) on Z ; i.e., they are of the form $(S, \omega|_S)$, where S is a leaf of the foliation $T\mathcal{F} = \text{Ker } \theta$.*

Proof. The local form of π from Proposition 3.7 implies that

$$\pi_Z := \pi|_Z \in \mathfrak{X}^2(Z)$$

is a Poisson structure on Z of rank $2n - 2$. Proposition 1.8 and the formula for the symplectic form (4.1) imply that the leaves of π_Z together with their symplectic structure are precisely the symplectic leaves of π that are included in Z .

In view of Proposition 4.19, to construct the cosymplectic structure (θ, ω) it suffices to find a Poisson vector field X on Z which is transverse to the foliation \mathcal{F}_{π_Z} . Assume first that M is orientable and fix a volume form $\mu \in \Omega^{2n}(M)$. Define the continuous function

$$(4.4) \quad \lambda := \left| \left\langle \bigwedge^n \pi, \mu \right\rangle \right| : M \rightarrow [0, \infty),$$

which is smooth on $M \setminus Z$. By definition, $Z = \lambda^{-1}(0)$. When M is not orientable, we construct a similar function as follows. Let \widetilde{M} be the oriented double cover of M and denote by $\tau : \widetilde{M} \rightarrow \widetilde{M}$ the nontrivial deck-transformation. Let $\widetilde{\pi}$ be the τ -invariant lift of π to \widetilde{M} and consider a volume form $\widetilde{\mu}$ on \widetilde{M} that is anti-invariant under τ ; i.e., $\tau^*(\widetilde{\mu}) = -\widetilde{\mu}$. Then $\widetilde{\lambda} = |\langle \bigwedge^n \widetilde{\pi}, \widetilde{\mu} \rangle|$ is τ -invariant, and so it is the lift of a function λ on M . Locally this function can be written as in (4.4).

We claim the following:

- (i) There is a unique smooth vector field $\widetilde{X}_{\log \lambda} \in \mathfrak{X}^1(M)$ extending:

$$X_{\log \lambda} \in \mathfrak{X}^1(M \setminus Z).$$

- (ii) $\widetilde{X}_{\log \lambda} \in \mathfrak{X}^1(M)$ is tangent to Z .

- (iii) The restriction $X := \widetilde{X}_{\log \lambda}|_Z \in \mathfrak{X}^1(Z)$ is a Poisson vector field for π_Z which is transverse to the foliation \mathcal{F}_{π_Z} .

This can be checked directly in the charts from Proposition 3.7. Namely, if μ_0 is a constant volume form in such coordinates, writing $\mu = \pm e^g \mu_0$, we obtain that

$$\tilde{X}_{\log \lambda} = \frac{\partial}{\partial v} + X_g,$$

which clearly satisfies the above conditions. \square

We note that the vector field $\tilde{X}_{\log \lambda}$ has appeared secretly in the 2-dimensional case in the proof of Proposition 3.5. It will appear again in Example 9.20, as the *modular vector field* of (M, π) . In the terminology of Chapter 8, (Z, π_Z) is a *complete Poisson submanifold* of (M, π) . 

Example 4.22 (Linear Poisson structures). Let \mathfrak{g} be the Lie algebra of a connected Lie group G . We have seen in Proposition 1.26 that the symplectic leaves of the linear Poisson structure $(\mathfrak{g}^*, \pi_{\mathfrak{g}})$ coincide with the coadjoint orbits of G . That was based on the fact that, for each $\xi \in \mathfrak{g}^*$, the coadjoint orbit $\mathcal{O}_{\xi} = G \cdot \xi$ has tangent space at ξ

$$T_{\xi} \mathcal{O}_{\xi} = \{\text{ad}_v^* |_{\xi} : v \in \mathfrak{g}\} = \text{Im } \pi_{\mathfrak{g}}^{\#} |_{\xi}.$$

Formula (4.1) shows that the symplectic form on \mathcal{O}_{ξ} is given by

$$\omega_{\mathcal{O}_{\xi}}(\text{ad}_v^* |_{\xi}, \text{ad}_w^* |_{\xi}) := -\xi([v, w]), \quad \xi \in \mathfrak{g}^*, \quad v, w \in \mathfrak{g}.$$

This is known as the **Kirillov-Kostant-Souriau (KKS) symplectic form** — also recalled in Example B.10.

Figure 4.2 sketches the symplectic foliations of the linear Poisson structures associated with the following 3-dimensional Lie algebras:

- orthogonal Lie algebra: $\mathfrak{so}(3, \mathbb{R}) = \{X \in \mathfrak{gl}(3, \mathbb{R}) : X + X^T = 0\}$,
- special linear Lie algebra: $\mathfrak{sl}(2, \mathbb{R}) = \{X \in \mathfrak{gl}(2, \mathbb{R}) : \text{tr } X = 0\}$,
- Euclidean Lie algebra: $\mathfrak{e}(2, \mathbb{R}) = \mathbb{R} \times \mathbb{R}^2$, for the action: $\lambda \cdot (x, y) = \lambda(-y, x)$,
- open book Lie algebra: $\mathfrak{b}_3 = \mathbb{R} \times \mathbb{R}^2$, for the action: $\lambda \cdot (x, y) = \lambda(x, y)$.

The details are left as an exercise. 

Example 4.23 (Hamiltonian G -spaces). We continue the discussion on Hamiltonian G -spaces from Section 1.5. So let (M, ω) be a Hamiltonian G -space with moment map $\mu : M \rightarrow \mathfrak{g}^*$, and assume that the action of G is proper and free. The quotient manifold M/G has a unique Poisson structure π for which the projection $p : M \rightarrow M/G$ is a Poisson map. As we saw in Section 1.5, the symplectic leaves are the connected components of the

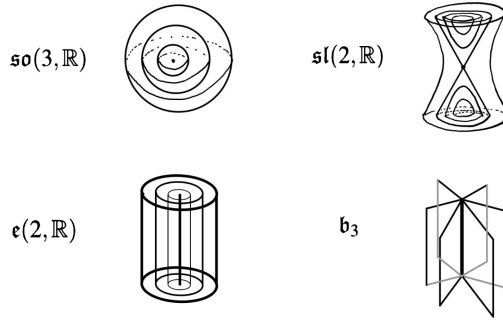

Figure 4.2. Symplectic foliations of 3-dimensional linear Poisson structures.

reduced spaces:

$$M //_{\mathcal{O}} G = \mu^{-1}(\mathcal{O})/G \subset M/G.$$

where $\mathcal{O} \subset \mathfrak{g}^*$ is any coadjoint orbit.

We now complete this discussion by identifying the symplectic forms on the leaves:

Proposition 4.24. *The symplectic leaves of M/G are the connected components of the reduced symplectic spaces $(M //_{\mathcal{O}} G, \omega_{\mathcal{O}})$.*

Let us start by recalling the definition of the reduced symplectic form — see Section B.2. It is the unique symplectic form $\omega_{\mathcal{O}}$ which for any $\xi \in \mathcal{O}$ satisfies

$$p_{\xi}^* \omega_{\mathcal{O}} = i_{\xi}^* \omega \quad \text{where} \quad \begin{array}{c} \mu^{-1}(\xi) \xrightarrow{i_{\xi}} M \\ \mu^{-1}(\xi) \xrightarrow{p_{\xi}} M //_{\mathcal{O}} G \end{array}$$

We fix a connected component

$$S \subset M //_{\mathcal{O}} G,$$

and we denote its pre-image in M by

$$\widehat{S} := p^{-1}(S) \subset \mu^{-1}(\mathcal{O}).$$

We need to check that

$$(4.5) \quad p_{\xi}^* \omega_S = i_{\xi}^* \omega \quad \text{on} \quad \widehat{S}_{\xi} := \widehat{S} \cap \mu^{-1}(\xi).$$

Fix $x \in \widehat{S}$, $y = p(x) \in S$, and $\xi = \mu(x) \in \mathcal{O}$. Our plan is to compute the symplectic form ω_S at y using the defining formula from Theorem 4.1 and check that it satisfies this equality.

The Poisson bivector π on the quotient space M/G is uniquely determined by the property that the projection $p : M \rightarrow M/G$ is a Poisson map. By Proposition 2.16, this is equivalent to the commutativity of the following diagram:

$$\begin{array}{ccc} T_x M & \xrightarrow{\text{dp}} & T_y(M/G) \\ (\omega^\flat)^{-1} \uparrow \sim & & \uparrow \pi^\sharp \\ T_x^* M & \xleftarrow{(\text{dp})^*} & T_y^*(M/G) \end{array}$$

Therefore, if for $\alpha \in T_y^*(M/G)$ we let $X_\alpha \in T_x M$ be defined by

$$p^* \alpha = i_{X_\alpha}(\omega),$$

the condition that p is a Poisson map implies that

$$\pi^\sharp \alpha = \text{dp}(X_\alpha).$$

We now return to our aim of proving identity (4.5) by applying formula (4.1). Note that this formula can be written as

$$\omega_S(\pi^\sharp \alpha, V) = \alpha(V),$$

for all $V \in T_y S$, $\alpha \in T_y^*(M/G)$. It follows that for any $Y \in T_x \widehat{S}$, we have

$$\omega_S(\pi^\sharp \alpha, \text{dp}(Y)) = \alpha(\text{dp}(Y)) \quad (V = \text{dp}(Y)).$$

Using the definition of X_α and that $\text{dp}(X_\alpha) = \pi^\sharp \alpha$, we can write this last identity as

$$\omega_S(\text{dp}(X_\alpha), \text{dp}(Y)) = \omega(X_\alpha, Y).$$

Note that this holds for all $\alpha \in T_y^*(M/G)$ and $Y \in T_x \widehat{S}$. In order to prove identity (4.5), we are left with showing that any $X \in T_x \widehat{S}_\xi$ is of type X_α for some α or, equivalently, that $i_X(\omega)$ vanishes on the kernel of dp . This follows from the fact that the fibers of the moment map are symplectic orthogonal to the orbits of the action — see Lemma 1.34. 

4.4. The coupling construction

In this section we will introduce a version of the *coupling construction*, which produces Poisson structures with a given symplectic leaf (S, ω) and a given isotropy Lie algebra \mathfrak{g} . It generalizes the linear Poisson structures on \mathfrak{g}^* — which is recovered when S is a point — and can be seen as providing “linear models” for Poisson structures around arbitrary symplectic leaves.

Let us consider first the case of a regular Poisson structure (M, π) . Then the “linear model” around a leaf we are looking for should give, in particular, a linear model for the underlying foliation \mathcal{F}_π around the leaf. Such linear models are well known in foliation theory. They can be constructed as

follows: starting with a connected manifold L (the leaf), one considers its universal covering space

$$p : \tilde{L} \rightarrow L.$$

This is a principal bundle with structure group the fundamental group $\pi_1(L)$. Given a representation $h : \pi_1(L) \rightarrow \mathrm{GL}(V)$ one forms the associated bundle

$$M^{\mathrm{lin}} := \tilde{L} \times_{\pi_1(L)} V.$$

On M^{lin} one has the foliation $\mathcal{F}^{\mathrm{lin}}$ whose leaves are the submanifolds

$$L_v := \{[(x, v)] : x \in \tilde{L}\} \quad (v \in V).$$

Note that $L \simeq L_0$ appears as the central leaf of this foliation. Also $\mathcal{F}^{\mathrm{lin}}$ is a very special foliation: each leaf L_v is an embedded submanifold and the projection $L_v \rightarrow L$, $(x, v) \mapsto v$, is a covering space. We call $(M^{\mathrm{lin}}, \mathcal{F}^{\mathrm{lin}})$ a **linear foliation**.

Given a foliation (M, \mathcal{F}) with an embedded leaf L the nearby leaves may fail to be embedded and/or be coverings of L (see, e.g., the Kornecker foliation). So, in general, we cannot expect $(M^{\mathrm{lin}}, \mathcal{F}^{\mathrm{lin}})$ to give a linear model for \mathcal{F} around L . Still, we have the following well-known result:

Theorem 4.25 (Reeb). *Let (M, \mathcal{F}) be a foliation with a leaf L whose universal covering space is compact. Then L has a neighborhood consisting of a union of leaves, isomorphic to a linear foliation.*

See, e.g., [122] for a proof. Note that the assumption in the theorem is equivalent to L being compact with finite fundamental group.

Moving to symplectic foliations, it is not hard to include a symplectic form in this construction: starting with a symplectic manifold (S, ω_S) we consider the pullback symplectic form on the universal covering space

$$p : \tilde{S} \rightarrow S, \quad \tilde{\omega}_S := p^* \omega_S.$$

Then this gives a closed form

$$\tilde{\omega} := \mathrm{pr}_{\tilde{S}}^* \tilde{\omega}_S \in \Omega^2(\tilde{S} \times V),$$

which is invariant under the action of $\pi_1(S)$, so it descends to closed 2-form ω on the quotient

$$M^{\mathrm{lin}} := \tilde{S} \times_{\pi_1(S)} V.$$

The restriction of ω to the leaves of $\mathcal{F}^{\mathrm{lin}}$ gives a foliated symplectic form $\omega_{\mathcal{F}}$. The resulting Poisson structure is too simpleminded to serve as a linear

model around a general symplectic leaf. Namely,

- it can only work around regular symplectic leaves, and
- even around a regular leaf, it only allows for families with constant symplectic structures, or more generally which admit a closed extension.

In order to solve these issues, we will now replace (i) the vector space V by the dual of a Lie algebra \mathfrak{g}^* , equipped with its linear Poisson structure, and (ii) the universal covering space by a principal G -bundle. We will also need to choose a principal bundle connection — this was hidden before in the fact that the universal covering space has a canonical flat principal connection. So the input data for our linear model is

- (i) a symplectic manifold (S, ω_S) ,
- (ii) a (right) principal G -bundle over S :

$$\begin{array}{c} P \curvearrowright G \\ \downarrow p \\ S \end{array}$$

- (iii) an auxiliary choice of principal bundle connection, i.e., a G -invariant 1-form $\theta \in \Omega^1(P, \mathfrak{g})$ satisfying

$$i_{\alpha(v)}\theta = v, \quad \forall v \in \mathfrak{g}.$$

The local model Poisson manifold will be defined on an open subset of the associated bundle:

$$P \times_G \mathfrak{g}^* := (P \times \mathfrak{g}^*)/G$$

(the quotient modulo the diagonal action of G). Moreover, it will be an open neighborhood of S viewed as the submanifold

$$S \simeq (P \times \{0\})/G \hookrightarrow P \times_G \mathfrak{g}^*.$$

We will obtain the Poisson structure using the general construction of Hamiltonian G -spaces.

First, we look for a symplectic form on $P \times \mathfrak{g}^*$ making this space into a Hamiltonian space with moment map the second projection

$$\mu : P \times \mathfrak{g}^* \rightarrow \mathfrak{g}^*, \quad \mu(x, \xi) = \xi.$$

To achieve this, we use the auxiliary connection $\theta \in \Omega^1(P, \mathfrak{g})$ and we pair it with μ to promote it to a 1-form on $P \times \mathfrak{g}^*$:

$$(4.6) \quad \tilde{\theta} = \langle \mu, \theta \rangle \in \Omega^1(P \times \mathfrak{g}^*).$$

This allows us to define a closed 2-form on $P \times \mathfrak{g}^*$:

$$(4.7) \quad \Omega := p^*\omega_S - d\tilde{\theta} \in \Omega^2(P \times \mathfrak{g}^*).$$

Exercise 4.26. Show the following:

- (i) Ω is G -invariant.
- (ii) Ω is nondegenerate at any point $(x, 0)$.
- (iii) The second projection $\mu : P \times \mathfrak{g}^* \rightarrow \mathfrak{g}^*$ satisfies the moment map condition with respect to Ω .

It follows from (i) and (ii) that the set on which Ω is nondegenerate,

$$O \subset P \times \mathfrak{g}^*,$$

is an open G -invariant set containing $P \times \{0\}$. In this way, we have constructed a Hamiltonian G -space $\mu : (O, \Omega) \rightarrow \mathfrak{g}^*$.

Definition 4.27. The **linear model** associated with a principal G -bundle P over a symplectic manifold (S, ω_S) with respect to a principal connection θ is

$$(4.8) \quad M^\theta(P, \omega_S) := O/G \subset (P \times \mathfrak{g}^*)/G$$

endowed with the quotient Poisson structure, denoted π^θ .

Remark 4.28. The linear model from the definition is the Poisson geometric version of the classical **coupling construction** from symplectic geometry. There is a more general construction, which includes both cases, where one replaces the coadjoint action of G on the linear Poisson manifold $(\mathfrak{g}^*, \pi_{\mathfrak{g}})$ by an arbitrary Hamiltonian G -space (F, π_F, μ_F) . This construction fits naturally in the setting of Dirac geometry discussed in Chapter 7 — see also Problem 4.12.

The following proposition lists some of the properties of this linear model:

Proposition 4.29. *For a linear model $(M^\theta(P, \omega_S), \pi^\theta)$, the following hold:*

- (i) *The natural map $P \times \{0\}/G \simeq S$ identifies the central symplectic leaf of $M^\theta(P, \omega_S)$ with (S, ω_S) .*
- (ii) *The isotropy Lie algebra at any point of this central leaf S is isomorphic to \mathfrak{g} .*

Moreover, two linear models $M^{\theta_1}(P, \omega_S)$ and $M^{\theta_2}(P, \omega_S)$ associated with different principal bundle connections are Poisson diffeomorphic around the central leaf.

The first item is straightforward to check. The second item follows from general properties of Hamiltonian quotients described in Problem 4.10. The independence on the choice of the connection 1-form θ will be dealt with later in Section 7.5.

We now have the following Poisson analogue of Reeb's Theorem:

Theorem 4.30 (Crainic and Mărcuț). *Let (M, π) a Poisson manifold with a symplectic leaf (S, ω_S) whose Poisson homotopy cover is compact and has vanishing second de Rham cohomology. Then S has a neighborhood consisting of a union of symplectic leaves, isomorphic to a linear model $(M^\theta(P, \omega_S), \pi^\theta)$.*

We will not prove this result here — see [49] — and the notion of *Poisson homotopy cover* will be discussed in Part 4 of the book. For now we observe that when the leaf reduces to a point $S = \{x_0\}$ the assumption on the Poisson homotopy cover amounts to the condition that the isotropy Lie algebra $\text{Ker } \pi_{x_0}^\sharp$ is semisimple and compact. Hence, for a zero of π the theorem recovers Conn's Linearization Theorem from Section 3.5.

Example 4.31 (Abelian case). It is instructive to detail the coupling construction (4.8) in the case where G is abelian. Assume first that $G = \mathbb{S}^1$. Hence the starting data is a principal \mathbb{S}^1 -bundle over a symplectic manifold,

$$\begin{array}{c} P \curvearrowright \mathbb{S}^1 \\ \downarrow p \\ (S, \omega_S) \end{array}$$

together with the auxiliary choice of a connection 1-form θ . Since $\mathfrak{g} = \mathbb{R}$, the induced infinitesimal \mathbb{S}^1 -action on P is encoded by a vector field

$$V = \alpha(1) : P \ni x \mapsto \left. \frac{d}{dt} \right|_{t=0} x \cdot e^{2\pi it},$$

and the connection 1-form $\theta \in \Omega^1(P)$ is an ordinary 1-form satisfying $\theta(V) = 1$. It then follows that $d\theta$ is basic; i.e., it can be written (uniquely) as

$$-d\theta = p^* \kappa_\theta, \quad \text{with } \kappa_\theta \in \Omega^2(S).$$

The 2-form κ_θ is known as the *curvature* of θ . It is a closed 2-form and its cohomology class, called the *Chern class* of the principal bundle P , is independent of θ and is an invariant of the principal bundle.

The coupling construction becomes very explicit. First, one has

$$\Omega = p^*(\omega_S) - d(t\theta) = p^*(\omega_S + t\kappa_\theta) - dt \wedge \theta \in \Omega^2(P \times \mathbb{R}),$$

where t stands for the real variable. Since the action of \mathbb{S}^1 on its Lie algebra \mathbb{R} is trivial, the linear model becomes

$$M^\theta(P, \omega_S) \subset (P \times \mathbb{R})/\mathbb{S}^1 = S \times \mathbb{R},$$

with symplectic leaves $S \times \{t\}$ endowed with the symplectic form

$$\omega_t = \omega_S + t\kappa_\theta.$$

In other words one obtains the trivial (product) foliation with the linear family of symplectic forms with variation the curvature of the connection.

Exercise 4.32. In general, $M^\theta(P, \omega_S)$ is not the entire $S \times \mathbb{R}$, but just an open set containing $S \times \{0\}$. Why? Show that if S is compact, $M^\theta(P, \omega_S)$ can be taken to be a product $S \times (-\epsilon, \epsilon)$.

Note that any other connection θ' is of the form $\theta' = \theta + p^*\eta$, and the resulting families are related by

$$\omega'_t = \omega_t - d(t\eta).$$

The Moser Lemma from symplectic geometry — recalled in Theorem B.8 — can now be applied on each leaf to show that the corresponding linear models are isomorphic. Later we will study a Poisson version of Moser's Lemma, which will imply the independence on the connection in general.

A similar description holds for the n -torus $\mathbb{T}^n = (\mathbb{S}^1)^n$: then θ has n -components, one obtains n curvature-form components

$$k_1, \dots, k_n \in \Omega^2(S),$$

and one ends up with the linear model

$$S \times \mathbb{R}^n, \quad \omega_{t_1, \dots, t_n} = \omega_S + t_1 \kappa_1 + \dots + t_n \kappa_n.$$

Problems

When asked to find the “symplectic foliation”, find the orbits together with the symplectic structure!

4.1. Find the symplectic foliation of the following linear Poisson manifolds (make also pictures!):

(a) $(\mathbb{R}^2, \pi_{\text{aff}(1, \mathbb{R})} = x \frac{\partial}{\partial x} \wedge \frac{\partial}{\partial y})$,

(b) $(\mathbb{R}^3, \pi_{\text{aff}(1, \mathbb{R}) \times \mathbb{R}} = x \frac{\partial}{\partial x} \wedge \frac{\partial}{\partial y})$,

(c) $(\mathbb{R}^3, \pi_{\text{heis}} = z \frac{\partial}{\partial x} \wedge \frac{\partial}{\partial y})$.

4.2. Show that the linear Poisson structure

$$\pi_{\mathfrak{e}(2, \mathbb{R})} = \left(x \frac{\partial}{\partial y} - y \frac{\partial}{\partial x} \right) \wedge \frac{\partial}{\partial z}$$

corresponds to the Euclidean Lie algebra

$$\mathfrak{e}(2, \mathbb{R}) = \mathbb{R} \ltimes \mathbb{R}^2, \quad \text{where } \mathbb{R} \text{ acts by } \lambda \cdot (x, y) = (-\lambda y, \lambda x).$$

Find its symplectic foliation.

4.3. Show that the linear Poisson structure

$$\pi_{\mathfrak{b}_3} = \left(x \frac{\partial}{\partial x} + y \frac{\partial}{\partial y} \right) \wedge \frac{\partial}{\partial z},$$

corresponds to the “open book Lie algebra”

$$\mathfrak{b}_3 = \mathbb{R} \ltimes \mathbb{R}^2, \quad \text{where } \mathbb{R} \text{ acts by } \lambda \cdot (x, y) = (\lambda x, \lambda y).$$

Find its symplectic foliation.

4.4. Find the symplectic foliation of the Poisson structure on \mathbb{R}^3 associated with the standard volume form $\mu = dx \wedge dy \wedge dz$ and the completely integrable 1-form $\theta = dC$, where $C(x, y, z) = x^2 + y^2 + \sin^2(z)$.

4.5. Let $\pi \in \mathfrak{X}^2(M)$ be a bivector field of constant rank. Assume that $\text{Im } \pi^\sharp$ is an involutive distribution with corresponding foliation \mathcal{F} ; i.e., $\text{Im } \pi^\sharp = T\mathcal{F}$. Show that the formula

$$\omega_{\mathcal{F}}(\pi^\sharp(\alpha), \pi^\sharp(\beta)) := -\pi(\alpha, \beta), \quad \alpha, \beta \in T_x^*M,$$

defines a foliated 2-form $\omega_{\mathcal{F}} \in \Omega^2(\mathcal{F})$, which satisfies

$$[\pi, \pi](\alpha, \beta, \gamma) = -d_{\mathcal{F}}\omega_{\mathcal{F}}(\pi^\sharp(\alpha), \pi^\sharp(\beta), \pi^\sharp(\gamma)), \quad \alpha, \beta, \gamma \in T_x^*M.$$

(HINT: Proof of Proposition 2.18.)

4.6. Let π be a regular Poisson structure on M with symplectic foliation \mathcal{F}_π and foliated symplectic form $\omega_{\mathcal{F}_\pi}$.

(a) Show that there exists a 2-form $\omega \in \Omega^2(M)$ extending the foliated symplectic form $\omega_{\mathcal{F}_\pi}$, i.e., such that for every symplectic leaf $i : S \hookrightarrow M$ one has

$$i^*\omega = \omega_{\mathcal{F}_\pi}|_S.$$

(b) Give an example that shows that, in general, the extension ω may not be taken to be a closed form.

(HINT: Consider a regular Poisson structure with a compact leaf on a manifold with $H^2(M) = \{0\}$.)

(c) Show that $\mathfrak{so}(3, \mathbb{R}) \setminus \{0\}$ with the restriction of the linear Poisson structure $\pi_{\mathfrak{so}(3, \mathbb{R})}$ is also an example for (b).

4.7. Let (M, π) be a Poisson manifold. Assume that there exists a 2-form $\omega \in \Omega^2(M)$ extending the symplectic forms on the leaves, i.e., such that for every symplectic leaf $i : (S, \omega_S) \hookrightarrow (M, \pi)$ one has

$$i^*\omega = \omega_S.$$

Show the following:

- (a) The image of the vector bundle map

$$T^*M \rightarrow T^*M, \quad \xi \mapsto \xi - \omega^\flat \circ \pi^\sharp(\xi)$$

is the family of isotropy Lie algebras of (M, π) .

- (b) (M, π) is a regular Poisson manifold.

4.8. Let (M^{2n+1}, π) be a regular Poisson manifold with $\text{rank } \pi = 2n$. Let X be a Poisson vector field transverse to the symplectic foliation \mathcal{F}_π . Show that one then obtains the following:

- (a) a closed 1-form θ satisfying

$$i_X\theta = 1, \quad \theta|_{T\mathcal{F}_\pi} = 0,$$

- (b) a closed 2-form ω satisfying

$$i_X\omega = 0, \quad \omega|_{T\mathcal{F}_\pi} = \omega_{\mathcal{F}_\pi},$$

- (c) a volume form

$$\mu := \theta \wedge \omega^n.$$

(HINT: Recall Koszul's formula for the de Rham differential.)

4.9. Let (S, Ω) be a symplectic manifold, and assume that there exists a symplectic vector field $X \in \mathfrak{X}(S, \Omega)$ which is transverse to a codimension-1 embedded submanifold $i : M \hookrightarrow S$.

- (a) Show that $\theta := i^*(i_X\Omega) \in \Omega^1(M)$ and $\omega := i^*\Omega \in \Omega^2(M)$ defines a cosymplectic structure on M .
 (b) Conversely, show that if (θ, ω) is a cosymplectic structure, then it can be obtained from a symplectic manifold as in (a).

4.10. Let (M, ω) be a free and proper Hamiltonian G -space with moment map $\mu : M \rightarrow \mathfrak{g}^*$. Consider M/G with the quotient Poisson structure. Fix $x \in M$ and denote the projection by $p : M \rightarrow M/G$. Show that the isotropy Lie algebra at $p(x) \in M/G$ is isomorphic to the isotropy Lie algebra \mathfrak{g}_ξ of the coadjoint action at $\xi := \mu(x)$,

$$\mathfrak{g}_\xi := \{v \in \mathfrak{g} : \text{ad}_v^*(\xi) = 0\}.$$

4.11. Apply the coupling construction from Section 4.4 to the following data:

- the symplectic manifold \mathbb{S}^2 endowed with the standard area form $\omega_{\mathbb{S}^2}$,
- the Hopf fibration, i.e., the principal \mathbb{S}^1 -bundle

$$p : \mathbb{S}^3 \rightarrow \mathbb{S}^2, \quad p(z_0, z_1) = (|z_0|^2 - |z_1|^2, 2i \overline{z_0} z_1),$$

where \mathbb{S}^1 acts on \mathbb{S}^3 via

$$(z_0, z_1) \cdot e^{i\varphi} = (z_0 e^{i\varphi}, z_1 e^{i\varphi}),$$

- the principal S^1 -connection form

$$\theta = -y dx + x dy - t dz + z dt \in \Omega^1(\mathbb{S}^3),$$

where $z_0 = x + iy$ and $z_1 = z + it$.

More precisely:

- (a) Check that these define a principal S^1 -bundle with connection.
- (b) Compute the resulting Poisson manifold $M^\theta(\mathbb{S}^3, \omega_{\mathbb{S}^2})$.
- (c) Consider the linear Poisson structure on \mathbb{R}^3 corresponding to $\mathfrak{so}(3, \mathbb{R})$, as in Exercise 1.27. Compare a neighborhood of the leaf $\mathbb{S}^2 \subset \mathbb{R}^3$ with $M^\theta(\mathbb{S}^3, \omega_{\mathbb{S}^2})$.

4.12. Consider the following data:

- a symplectic manifold (S, ω_S) ,
- a principal G -bundle $p : P \rightarrow S$,
- a G -Hamiltonian (Poisson) space (F, π_F, μ_F) ,
- a principal bundle connection $\theta \in \Omega^1(P, \mathfrak{g})$.

Let $x_0 \in F$ be a zero of the Poisson structure π_F . Construct a Poisson structure in a neighborhood of $S \simeq (P \times \{x_0\})/G$ in $P \times_G F$, which generalizes the linear model from Definition 4.27.

4.13. Show that two points x, y in a Poisson manifold (M, π) belong to the same leaf if and only if there exists a smooth path $a : [0, 1] \rightarrow T^*M$ with base path denoted $\gamma : [0, 1] \rightarrow M$ such that

$$\gamma(0) = x, \quad \gamma(1) = y, \quad \text{and} \quad \pi^\sharp(a(t)) = \frac{d\gamma}{dt}(t), \quad \forall t \in [0, 1].$$

These types of paths will play a crucial role in later chapters.

Poisson Transversals

In a Poisson manifold, besides the symplectic geometry along the leaves, interesting geometric phenomena also occur in directions transverse to the leaves. We have already seen a glimpse of this in the notion of the isotropy Lie algebra. In this chapter we initiate the study of the transverse geometry of the leaves, which we will frequently encounter in the rest of the book.

5.1. Slices and Poisson transversals

Definition 5.1. Let (M, π) be a Poisson manifold, $x \in M$, and let S be the symplectic leaf through x . A **slice** of (M, π) to S at x is any embedded submanifold $X \subset M$ containing x and satisfying

$$(5.1) \quad T_x M = T_x S \oplus T_x X.$$

Condition (5.1) is equivalent to

$$(5.2) \quad T_x M = \pi^\sharp(T_x^* M) \oplus T_x X.$$

This equality may fail at points of X arbitrarily close to x simply because leaves near S may have strictly larger dimension. However, continuity of π^\sharp and (5.2) imply that for any point $y \in X$ sufficiently close to x one still has that X is transverse to the leaf S' through y :

$$T_y M = T_y S' + T_y X.$$

Hence, a neighborhood of x in X will intersect any nearby leaf S' in a submanifold. The intersection may have positive dimension if the dimension of S' is larger than that of S .

Our next aim is to discuss the Poisson geometry of slices and how two different slices to the same symplectic leaf are related. For this, the following notion will play a fundamental role:

Definition 5.2. Let (M, π) be a Poisson manifold. A **Poisson transversal** of (M, π) is any embedded submanifold $X \subset M$ with the property that

$$(5.3) \quad T_y M = T_y X + (T_y X)^{\perp\pi}, \quad \forall y \in X,$$

where the π -orthogonal \perp_π is defined by

$$(5.4) \quad (T_y X)^{\perp\pi} := \pi_y^\sharp((T_y X)^\circ).$$

Poisson transversals also appear in the literature under the name of “cosymplectic submanifolds” — see Exercise 5.7 for a possible explanation of this terminology.

In this definition, the “ π -orthogonal” is a generalization of the notion of symplectic orthogonal. Recall that if $W \subset V$ is a vector subspace of a symplectic vector space (V, ω) , then its symplectic orthogonal $W^{\perp\omega}$ is

$$W^{\perp\omega} := \{v \in V : \omega(v, w) = 0, \forall w \in W\} = (\omega^b)^{-1}(W^\circ),$$

where $W^\circ \subset V^*$ denotes the annihilator of W .

In the case of a Poisson structure one checks that the π -orthogonal (5.4) can also be described as

$$(5.5) \quad (T_y X)^{\perp\pi} = (T_y X \cap T_y S)^{\perp\omega_S} \subset T_y S,$$

where (S, ω_S) is the symplectic leaf through y . In particular,

$$(5.6) \quad ((T_y X)^{\perp\pi})^{\perp\pi} = T_y S \cap T_y X.$$

Hence, the operation \perp_π is not an involution unless S is open.

On the other hand, from the definition of $(T_y X)^{\perp\pi}$, it follows that

$$\dim(T_y X)^{\perp\pi} \leq \dim(T_y X)^\circ = \dim M - \dim X.$$

Thus, the Poisson transversal condition (5.3) is equivalent to its direct sum version:

$$(5.7) \quad T_y M = T_y X \oplus (T_y X)^{\perp\pi}.$$

Note that open subsets provide simple examples of Poisson transversals. Here is a more interesting class of examples:

Exercise 5.3. For a symplectic manifold (M, ω) , prove that Poisson transversals are the same thing as symplectic submanifolds.

Exercise 5.4. For a regular Poisson manifold (M, π) of corank q , show that any Poisson transversal of dimension q is the same as a submanifold that intersects the leaves transversally.

Note that condition (5.3) is an open condition: if it is satisfied at y , then it is satisfied in a neighborhood of y in X . This is the reason why small enough slices provide examples of Poisson transversals:

Lemma 5.5. *If X is a slice of S at x , then a small enough open neighborhood $U \subset X$ of x is a Poisson transversal.*

Proof. If X is a slice of S at x , then $T_x X \cap T_x S = \{0\}$ and so, by (5.5), the π -orthogonal at x is

$$(T_x X)^{\perp\pi} = (T_x X \cap T_x S)^{\perp\omega_S} = T_x S.$$

Using again that X is a slice at x , we obtain that

$$T_x M = T_x X \oplus T_x S = T_x X \oplus (T_x X)^{\perp\pi}.$$

Since this last condition is open, we are done. \square

An important property of Poisson transversals is that they naturally inherit a Poisson structure. A first result in this direction is the following:

Proposition 5.6. *Given a Poisson manifold (M, π) , an embedded submanifold $X \subset M$ is a Poisson transversal if and only if X intersects each symplectic leaf (S, ω_S) transversally in a symplectic submanifold of S . In particular, each $(X \cap S, \omega_S|_{X \cap S})$ is a smooth symplectic manifold.*

Proof. The condition in the proposition means that, for every symplectic leaf (S, ω_S) , we have the following:

- (i) $T_y M = T_y X + T_y S, \forall y \in S \cap X$.
- (ii) $\omega_S|_{T_y X \cap T_y S}$ is nondegenerate for all $y \in S \cap X$.

Note that (ii) is equivalent to $T_y S \cap T_y X$ intersecting its symplectic orthogonal inside $(T_y S, \omega_S)$ in $\{0\}$ or, using (5.5), to

$$(T_y X)^{\perp\pi} \cap T_y S \cap T_y X = \{0\}.$$

This combined with $(T_y X)^{\perp\pi} \subset T_y S$ shows that (ii) is equivalent to

$$(ii') \quad (T_y X)^{\perp\pi} \cap T_y X = \{0\}.$$

It is now clear that if the Poisson transversality condition (5.7) holds, then (i) and (ii') hold. Conversely, (i) gives

$$\dim(T_y X)^{\perp\pi} = \dim S - \dim(T_y X \cap T_y S) \stackrel{(i)}{=} \dim(T_y M) - \dim(T_y X),$$

which together with (ii') yield (5.7). So X is a Poisson transversal. \square

Exercise 5.7. Show that X is a Poisson transversal if and only if the pairing induced by π on the conormal bundle

$$\sigma_X : (TX)^\circ \times (TX)^\circ \rightarrow \mathbb{R}, \quad (\alpha, \beta) \mapsto \pi(\alpha, \beta)$$

is nondegenerate. In particular, Poisson transversals have even codimension.

Exercise 5.8. Consider the 3-dimensional Poisson structures from Examples 4.14, 4.15, and 4.22. Find Poisson transversals in these Poisson manifolds. Which ones admit closed/compact Poisson transversals? What dimensions can these have?

As promised, we now show that Poisson transversals inherit Poisson structures:

Proposition 5.9. *Any Poisson transversal X in a Poisson manifold (M, π) carries a Poisson structure π_X , uniquely determined by the condition that its symplectic leaves are the connected components of the intersections*

$$(X \cap S, \omega_S|_{X \cap S}), \quad S \in \mathcal{F}_\pi.$$

Corollary 5.10. *If X is a slice of S at x , then a small enough open neighborhood $U \subset X$ of x has an induced Poisson structure.*

Note that any Weinstein splitting chart (3.1) at x gives rise to a slice $X = \chi^{-1}(\{0\} \times W)$ with induced Poisson structure π_X corresponding to the Poisson structure θ on W . In particular, the Poisson structure on the slice vanishes around x if and only if x is a regular point.

Proof of Proposition 5.9. The Poisson transversal condition

$$T_y M = T_y X \oplus (T_y X)^{\perp\pi}$$

gives a dual decomposition:

$$T_y^* M = ((T_y X)^{\perp\pi})^\circ \oplus (T_y X)^\circ.$$

The map $\pi_y^\sharp : T_y^* M \rightarrow T_y M$ preserves this decomposition:

$$\pi_y^\sharp(((T_y X)^{\perp\pi})^\circ) \subset (T_y X), \quad \pi_y^\sharp((T_y X)^\circ) = (T_y X)^{\perp\pi}.$$

Indeed, the second equality is just the definition of \perp_π , while the first inclusion is the statement

$$((T_y X)^{\perp\pi})^{\perp\pi} \subset T_y X,$$

which follows from (5.6).

The dual decomposition also gives an isomorphism $T_y^* X \simeq ((T_y X)^{\perp\pi})^\circ$, so we obtain a bivector field $\pi_X \in \mathfrak{X}^2(X)$ whose associated bundle map is the composition

$$(5.8) \quad \pi_X^\sharp : T^* X \xrightarrow{\simeq} ((TX)^{\perp\pi})^\circ \xrightarrow{\pi^\sharp} TX.$$

More explicitly,

$$\pi_X(\xi, \eta) := \pi(\tilde{\xi}, \tilde{\eta}),$$

where $\tilde{\xi} \in T_y^*M$ denotes the unique extension of $\xi \in T_y^*X$ vanishing on $(T_yX)^{\perp\pi}$.

By Proposition 2.24, for each $y \in X$, the bivector $\pi_X|_y$ is encoded in a symplectic vector space (W_y, ω_y) with $W_y \subset T_yX$. Note that from the definition of π_X ,

$$W_y = \text{Im}(\pi_X^\sharp|_y) = ((T_yX)^{\perp\pi})^{\perp\pi} = T_yX \cap T_yS.$$

Moreover, from formula (2.15) it follows also that

$$\omega_y = \omega_S|_{T_y(X \cap S)}.$$

In view of Proposition 1.8, the only thing we are left to prove is that π_X is a Poisson bivector. For this, we observe that on the open dense set where π_X is regular the previous argument shows that (i) $\text{Im} \pi_X^\sharp$ is an integrable distribution $T\mathcal{F}$ with leaves $S \cap X$ and (ii) the induced nondegenerate 2-form $\omega_{\mathcal{F}}$ on this distribution,

$$\omega_{\mathcal{F}}(\pi_X^\sharp(\alpha), \pi_X^\sharp(\beta)) = -\pi_X(\alpha, \beta),$$

restricts to each leaf as the symplectic form $\omega_S|_{S \cap X}$. In particular, $\omega_{\mathcal{F}}$ is closed. By Theorem 4.13, $[\pi_X, \pi_X] = 0$ on this open set; hence $[\pi_X, \pi_X] = 0$ on all of X . \square

From the proof of the proposition, we obtain the following algebraic expression for the induced Poisson structure.

Corollary 5.11. *The induced Poisson structure π_X on a Poisson transversal X in (M, π) is determined by*

$$\pi_X^\sharp : T^*X \rightarrow TX, \quad \pi_X^\sharp(\alpha) = \pi^\sharp(\tilde{\alpha})$$

where $\tilde{\alpha} \in T_x^*M$ is the extension of α that vanishes on $(T_xX)^{\perp\pi}$.

Exercise 5.12. Let X be a Poisson transversal of (M, π) . Consider the decomposition induced by (5.7):

$$(5.9) \quad \bigwedge^2 T_X M = \bigwedge^2 TX \oplus (TX \otimes (TX)^{\perp\pi}) \oplus \bigwedge^2 (TX)^{\perp\pi}.$$

Show that with respect to this decomposition

$$\pi|_X = \pi_X + \sigma_X \in \bigwedge^2 TX \oplus \bigwedge^2 (TX)^{\perp\pi},$$

where π_X is the induced Poisson structure on X and σ_X is the form from Exercise 5.7, properly interpreted (use the identification $(TX)^{\perp\pi} \simeq ((TX)^\circ)^*$).

The next exercise gives a direct description of the Poisson bracket induced on a Poisson transversal.

Exercise 5.13. Let (M, π) be a Poisson manifold, let

$$F = (c_1, \dots, c_k) : M \rightarrow \mathbb{R}^k$$

be a smooth map with a regular value at 0, and assume that

$$X = \{x \in M : c_1(x) = 0, \dots, c_k(x) = 0\} = F^{-1}(0)$$

is a Poisson transversal in (M, π) . Show that the $k \times k$ -matrix of Poisson brackets $c_{ij}(x) := \{c_i, c_j\}(x)$ is invertible for every $x \in X$ and that the Poisson bracket $\{\cdot, \cdot\}_X$ on X corresponding to π_X is given by the *Dirac bracket*

$$\{f, g\}_X = \left(\{\tilde{f}, \tilde{g}\} - \sum_{i,j} \{\tilde{f}, c_i\} c^{ij} \{c_j, \tilde{g}\} \right) \Big|_X,$$

where $\tilde{f}, \tilde{g} \in C^\infty(M)$ are any extensions of $f, g \in C^\infty(X)$ to M and the c^{ij} denote the entries of the inverse of the matrix (c_{ij}) .

Notice that, in general, the inclusion $(X, \pi_X) \hookrightarrow (M, \pi)$ of a Poisson transversal *is not* a Poisson map — in other words, a Poisson transversal *is not* a Poisson submanifold in the sense of Chapter 8. The following exercise and example illustrate this difference.

Exercise 5.14. Show that if (S, ω) is a symplectic manifold, then for a Poisson transversal $i : X \hookrightarrow S$ the induced Poisson structure on X corresponds to the symplectic structure $i^*\omega$ — see Exercise 5.3.

Example 5.15. Given a Poisson manifold (M, π) , two commuting Poisson vector field $X, Y \in \mathfrak{X}(M, \pi)$, and a real number $\lambda \in \mathbb{R}$, one obtains a Poisson structure (see Problem 2.3) on $M \times \mathbb{R}^2$ by setting

$$\pi_\lambda := \pi + X \wedge \frac{\partial}{\partial t} + Y \wedge \frac{\partial}{\partial s} + \lambda \frac{\partial}{\partial t} \wedge \frac{\partial}{\partial s}.$$

One finds that for any $x_0 \in \mathbb{R}^2$, the submanifold

$$M \simeq M \times \{x_0\} \subset M \times \mathbb{R}^2$$

is a Poisson transversal in $(M \times \mathbb{R}^2, \pi_\lambda)$, provided $\lambda \neq 0$. The induced Poisson structure on M is

$$\pi - \frac{1}{\lambda} X \wedge Y \in \mathfrak{X}^2(M). \quad \text{🐟}$$

The following proposition is a first indication that a Poisson transversal captures the transverse Poisson geometry to the leaves.

Proposition 5.16. *Let X be a Poisson transversal in a Poisson manifold (M, π) . Then, at any $x \in X$, the isotropy Lie algebras of (X, π_X) and (M, π) are isomorphic.*

Proof. This follows because a slice Y in (X, π_X) at x will also be a slice in (M, π) and the isotropy Lie algebra encodes the linearization of the Poisson structure on the slice at x . \square

Also related to the transverse geometry, one has the **leaf space** of the Poisson manifold (M, π) . It is defined as the set of leaves M/\mathcal{F}_π endowed with the quotient topology. In general this is a very wild space. Still, given a Poisson transversal X , Proposition 5.9 shows that one has an induced map

$$X/\mathcal{F}_{\pi_X} \rightarrow M/\mathcal{F}_\pi,$$

which can be used to probe the leaf space. Indeed, X/\mathcal{F}_{π_X} can be much simpler and the map has the following properties:

Proposition 5.17. *The map $X/\mathcal{F}_{\pi_X} \rightarrow M/\mathcal{F}_\pi$ is continuous and open. In particular, if X intersects each leaf at most once, then X/\mathcal{F}_{π_X} is homeomorphic to an open subspace of M/\mathcal{F}_π .*

The proof is left to the reader and follows from the following version of the Weinstein Splitting Theorem around Poisson transversals.

Exercise 5.18. Let X be a Poisson transversal in a Poisson manifold (M, π) of codimension $2s$. Show that for any point $x \in X$, there is a Poisson diffeomorphism

$$\chi : (U, \pi) \xrightarrow{\simeq} (V, \pi_{\text{can}}) \times (W, \pi_X),$$

where $U \subset M$ is a neighborhood of x , $V \subset \mathbb{R}^{2s}$ is an open set endowed with the canonical Poisson structure π_{can} , and $W \subset X$ is a neighborhood of x .

5.2. The transverse Poisson structure to a leaf

We saw in the previous section that any small enough slice to a symplectic leaf is a Poisson transversal, and so it inherits a Poisson structure. We now establish that any two germs of slices to the same symplectic leaf are Poisson diffeomorphic. Therefore, we obtain an important transverse Poisson invariant associated to the symplectic leaf.

Theorem 5.19. *Let (M, π) be a Poisson manifold, let S be a symplectic leaf, and assume that X_0 and X_1 are slices to S at x_0 and x_1 , respectively. Then there exist open neighborhoods $x_i \in V_i \subset X_i$, $i \in \{0, 1\}$, which are Poisson transversals and which are isomorphic via a Poisson diffeomorphism*

$$\psi : (V_0, \pi_{V_0}) \xrightarrow{\simeq} (V_1, \pi_{V_1}) \quad \text{with} \quad \psi(x_0) = x_1.$$

We will present two different approaches to prove this theorem.

Proof. We will show that there exists a Hamiltonian diffeomorphism (recall Definition 1.11) $\phi : M \rightarrow M$, such that $\phi(x_0) = x_1$, and $V_1 := \phi(V_0) \subset X_1$, for some small neighborhood $V_0 \subset X_0$ of x_0 , which is a Poisson transversal. Then ϕ restricts to a Poisson diffeomorphism between the induced Poisson structure:

$$\phi|_{V_0} : (V_0, \pi_{V_0}) \xrightarrow{\sim} (V_1, \pi_{V_1}).$$

First, since x_0 and x_1 belong to the same leaf, we find a Hamiltonian diffeomorphism ϕ with $\phi(x_0) = x_1$. Thus, by replacing X_0 by the slice $\phi(X_0)$ through x_1 , we may assume that $x_0 = x_1 = x$.

Next, fix a splitting chart $(O \subset \mathbb{R}^{2s}, \pi_{\text{can}}) \times (W, \pi_W)$ centered at x . Clearly, it is enough to prove the theorem assuming that $X_0 := \{0\} \times W$ is one of the slices at $x = (0, 0)$. The other slice $X_1 \subset M$, because it is transverse to $O \times \{0\}$ at x , it is given around x as the graph of a smooth function

$$F : W \rightarrow \mathbb{R}^{2s}, \quad \text{with } F(0) = 0.$$

In other words, after shrinking W , we can assume that

$$X_1 = \{(F(w), w) : w \in W\} \subset \mathbb{R}^{2s} \times W.$$

Note that X_0 and X_1 can be joined by the smooth family of slices at $x = (0, 0)$:

$$X_t := \{(tF(w), w) : w \in W\}, \quad t \in [0, 1].$$

In order to conclude the proof, we construct a smooth family of functions $H_t \in C^\infty(M)$, $t \in [0, 1]$, whose Hamiltonian flow $\phi_{X_H}^t := \Phi_{X_H}^{t,0}$ satisfies

$$(5.10) \quad \phi_{X_H}^t(x) = x \quad \text{and} \quad \phi_{X_H}^t(V_0) \subset X_t, \quad \forall t \in [0, 1],$$

where $V_0 \subset X_0$ is a small neighborhood of x . The second condition will hold if we require that the vector field $X_{H_t} + \frac{\partial}{\partial t}$ on $M \times [0, 1]$ is tangent to the submanifold

$$\tilde{X} := \{(u, t) : u \in X_t\} \subset M \times [0, 1].$$

It is easy to see that this condition is equivalent to

$$(5.11) \quad F(w) - X_{H_t}|_{i_t(w)} \in T_{i_t(w)}X_t, \quad \forall (w, t) \in W \times [0, 1],$$

where $i_t(w) = (tF(w), w)$ is the parameterization of X_t and $F(w) \in \mathbb{R}^{2s}$ is viewed as a constant vector.

As in Lemma 5.5, after shrinking W we may assume that the slice X_t is in fact a Poisson transversal for all $t \in [0, 1]$. Then, we have a unique decomposition:

$$F(w) = T_t(w) + N_t(w) \in T_{i_t(w)}X_t \oplus (T_{i_t(w)}X_t)^\perp.$$

Since $\pi^\sharp : (T_{i_t(w)}X_t)^\circ \xrightarrow{\sim} (T_{i_t(w)}X_t)^\perp$ is an isomorphism, we can write uniquely

$$N_t(w) = \pi^\sharp(\beta_t(w)), \quad \beta_t(w) \in (T_{i_t(w)}X_t)^\circ.$$

Under the splitting $T_{i_t(w)}^*(\mathbb{R}^{2s} \times W) = T_{tF(w)}^*\mathbb{R}^{2s} \times T_w^*W$ elements in $(T_{i_t(w)}X_t)^\circ$ can be written as $\alpha - (tF)^*(\alpha)$, with $\alpha \in T_{tF(w)}^*\mathbb{R}^{2s} \cong \mathbb{R}^{2s}$. Thus, we can write

$$\beta_t(w) = (\alpha_t(w), -(tF)^*(\alpha_t(w))), \quad \alpha_t(w) \in \mathbb{R}^{2s}.$$

Choose a smooth family of functions $H_t \in C_c^\infty(M)$ such that, around x , it satisfies

$$H_t(u, w) := \langle \alpha_t(w), u - tF(w) \rangle, \quad (u, w) \in \mathbb{R}^{2s} \times W.$$

It is easy to see that $(dH_t)_{i_t(w)} = \beta_t(w)$, and so $X_{H_t}|_{i_t(w)} = N_t(w)$; thus (5.11) holds. Finally, since $i_t(0) = (0, 0)$, it follows that $N_t(0) = 0$; thus X_{H_t} vanishes at x , and so we also obtain the first condition from (5.10): $\phi_{X_H}^t(x) = x$. \square

The second proof of Theorem 5.19 will be based on a Moser-type theorem in Poisson geometry. To state this result, we introduce the following natural equivalence relation for Poisson structures on a manifold.

Definition 5.20. Two Poisson structures π_0 and π_1 on a manifold M are said to be **gauge equivalent** if they have the same leaves and there is a closed 2-form $B \in \Omega^2(M)$ such that for each leaf S the symplectic forms ω_S^0 and ω_S^1 of π_0 and π_1 are related by

$$\omega_S^1 - \omega_S^0 = B|_S.$$

We also say that π_1 is the **B -gauge transform** of π_0 and write $\pi_1 = e^B\pi_0$.

Since a Poisson structure is uniquely determined by its symplectic foliation, π_1 is completely determined by π_0 and B . The notation $e^B\pi_0$ will become clear in Section 7.1.

As in the first proof of Theorem 5.19, using Hamiltonian flows, we may assume that both slices pass through the same point. Then the following result shows that the induced Poisson structures are gauge equivalent:

Lemma 5.21. *Let (M, π) be a Poisson manifold, let S be a symplectic leaf, and assume that X_0 and X_1 are slices to S at x . Then, up to a Poisson diffeomorphism, the germs of X_0 and X_1 at x are gauge equivalent through an exact form $B = d\alpha$: there exist neighborhoods $V_i \subset X_i$ of x and a diffeomorphism $\phi : V_0 \xrightarrow{\sim} V_1$ fixing x and such that $\phi_*\pi_{V_0} = e^B\pi_{V_1}$.*

Proof. Consider a splitting chart $(\mathbb{R}^{2s}, \pi_{\text{can}}) \times (W, \pi_W)$ centered at x . Clearly, it suffices to prove the result when one of the slices is $X_0 = \{0\} \times W$ and the other slice is given as the graph of a smooth function $F : W \rightarrow \mathbb{R}^{2s}$:

$$X_1 = \{(F(w), w) : w \in W\} \subset \mathbb{R}^{2s} \times W, \quad F(0) = 0.$$

We use the diffeomorphisms $\phi_1 : X_1 \xrightarrow{\sim} W$ induced by the second projection. Then it is clear that $(\phi_0)_*(\pi_{X_0}) = \pi_W$, and we leave it as an exercise to check that

$$(\phi_1)_*\pi_{X_1} = e^B \pi_W, \quad \text{with} \quad B = F^* \omega_{\text{can}}. \quad \square$$

The proof of Theorem 5.19 is now reduced to a statement about gauge equivalent Poisson structures through an *exact* 2-form. This is precisely the context in which the usual Moser argument from symplectic geometry (Theorem B.8) applies. We give here one Poisson version of Moser’s Lemma and we will see other Poisson versions later.

Theorem 5.22 (Moser’s Lemma). *Let M be a compact manifold, let $\{\pi_t\}_{t \in [0,1]}$ be a smooth path of Poisson structures on M , and assume that*

$$\pi_t = e^{B_t} \pi_0.$$

If B_t is trivial in cohomology,

$$B_t = d\alpha_t,$$

for a smooth family of 1-forms α_t , then (M, π_0) and (M, π_1) are Poisson diffeomorphic.

The proof is entirely identical to that of the usual Moser Lemma for symplectic structures, so it is left as an exercise. The second proof of Theorem 5.19 can now be completed by applying the obvious local version of Theorem 5.22 — for the classical versions in symplectic geometry, see [29].

Definition 5.23. Let (M, π) be a Poisson manifold, and let S be a symplectic leaf. The Poisson isomorphism class of any germ of a slice X to S is called the **transverse Poisson structure** to S .

Example 5.24 (Transverse Poisson structure to a coadjoint orbit). Let $(\mathfrak{g}, [\cdot, \cdot])$ be a Lie algebra and consider the linear Poisson structure $\pi_{\mathfrak{g}}$ on \mathfrak{g}^* . Note that a proper linear subspace is never a Poisson transversal since the defining condition (5.3) can never hold at the origin $0 \in \mathfrak{g}^*$.

If we fix $\xi \in \mathfrak{g}^*$, we can obtain a slice at ξ as follows. Denote by \mathfrak{g}_{ξ} the isotropy Lie algebra at ξ for the coadjoint action:

$$\mathfrak{g}_{\xi} := \{v \in \mathfrak{g} : \text{ad}_v^*(\xi) = 0\}.$$

Notice that the tangent space to the symplectic leaf through ξ , i.e., the coadjoint orbit \mathcal{O}_{ξ} — see Example 4.22 — coincides with the annihilator of \mathfrak{g}_{ξ} :

$$T_{\xi} \mathcal{O}_{\xi} = \{\text{ad}_v^*(\xi) : v \in \mathfrak{g}\} = (\mathfrak{g}_{\xi})^{\circ}.$$

Therefore, if $c \subset \mathfrak{g}$ is any linear subspace complementary to \mathfrak{g}_ξ ,

$$\mathfrak{g} = \mathfrak{g}_\xi \oplus c,$$

then the affine space $\xi + c^\circ \subset \mathfrak{g}^*$ is a slice at ξ .

In particular, an open neighborhood X of ξ in the affine space $\xi + c^\circ$ is a Poisson transversal in $(\mathfrak{g}^*, \pi_{\mathfrak{g}})$, whose germ at ξ represents the transverse Poisson structure to the orbit \mathcal{O}_ξ . Examples show that the induced Poisson structure π_X need not be linear or even linearizable at ξ . However, we claim the following:

- (i) If the complement c satisfies $[\mathfrak{g}_\xi, c] \subset c$, then π_X is an affine Poisson structure equivalent to a linear one.
- (ii) If the complement c is a Lie subalgebra, $[c, c] \subset c$, then π_X is at most quadratic, nonhomogenous, and it may fail to be linearizable.

For (i) we leave it as an exercise to check that the map

$$\phi : X \rightarrow \mathfrak{g}_\xi^*, \quad \eta \mapsto (\eta - \xi)|_{\mathfrak{g}_\xi},$$

is a Poisson diffeomorphism between (X, π_X) and an open neighborhood around 0 in the linear Poisson manifold $(\mathfrak{g}_\xi^*, \pi_{\mathfrak{g}_\xi})$. On the other hand, (ii) follows from an explicit computation using the Dirac bracket from Exercise 5.13 — see [128].

Exercise 5.25. Let \mathfrak{g} be the Lie algebra of a compact Lie group G . Show that for every $\xi \in \mathfrak{g}^*$ there exists a linear subspace $c \subset \mathfrak{g}$ such that

$$\mathfrak{g} = \mathfrak{g}_\xi \oplus c \quad \text{and} \quad [\mathfrak{g}_\xi, c] \subset c.$$

In particular, the transverse Poisson structure to any coadjoint orbit of a compact Lie algebra is linearizable.

HINT: \mathfrak{g} has an inner product (\cdot, \cdot) such that

$$([u, v], w) + (v, [u, w]) = 0, \quad \forall u, v, w \in \mathfrak{g}. \quad \text{👉}$$

5.3. Poisson maps and Poisson transversals

The relevance of Poisson transversals in Poisson geometry derives in part from the fact that they behave functorially under pullbacks by Poisson maps.

Proposition 5.26. *Let $\phi : (M, \pi) \rightarrow (N, \theta)$ be a Poisson map, and let $Y \subset N$ be a Poisson transversal. Then:*

- (i) ϕ is transverse to Y .
- (ii) $X := \phi^{-1}(Y)$ is a Poisson transversal in M .
- (iii) The restriction $\phi : (X, \pi_X) \rightarrow (Y, \theta_Y)$ is a Poisson map.

Proof. Let $x \in X$ and denote $y := \phi(x) \in Y$. Since ϕ is a Poisson map, Proposition 2.16 gives

$$(5.12) \quad \theta^\sharp(\alpha) = d_x\phi(\pi^\sharp(\phi^*(\alpha))), \quad \forall \alpha \in T_y^*N.$$

This, together with the assumption that Y is a Poisson transversal, shows that ϕ is transverse to Y :

$$T_yN = T_yY + \theta^\sharp(T_y^*N) = T_yY + d_x\phi(T_xM).$$

As a consequence, X is an embedded submanifold of M and

$$T_xX = (d_x\phi)^{-1}(T_yY) \quad \text{and} \quad (T_xX)^\circ = \phi^*((T_yY)^\circ).$$

To show that X is a Poisson transversal, we verify (5.3). Let $V \in T_xM$, and decompose $d_x\phi(V) = U + \theta^\sharp(\alpha)$, with $U \in T_yY$ and $\alpha \in (T_yY)^\circ$. Then $\phi^*(\alpha) \in (T_xX)^\circ$, and by (5.12), $W := V - \pi^\sharp(\phi^*(\alpha))$ is mapped by $d_x\phi$ to U . Hence $W \in T_xX$ and

$$V = W + \pi^\sharp(\phi^*(\alpha)) \in T_xX + \pi^\sharp((T_xX)^\circ).$$

This shows that (5.3) holds, so X is a Poisson transversal.

For $\alpha \in T_y^*Y$ we denote by $\tilde{\alpha}$ its unique extension to T_y^*N that vanishes on $(T_yY)^{\perp\theta}$, and we use similar notations for elements in T_x^*X . Since

$$\begin{aligned} d_x\phi((T_xX)^{\perp\pi}) &= d_x\phi(\pi^\sharp((T_xX)^\circ)) = d_x\phi(\pi^\sharp(\phi^*((T_yY)^\circ))) \\ &= \theta^\sharp((T_yY)^\circ) = (T_yY)^{\perp\theta}, \end{aligned}$$

it follows that $\phi^*(\tilde{\alpha}) = \widetilde{\phi^*(\alpha)}$, for $\alpha \in T_y^*Y$. Using this and the description of the Poisson structure on a Poisson transversal (5.8), we find that for any $\alpha \in T_y^*Y$

$$d_x\phi(\pi_X^\sharp(\phi^*(\alpha))) = d_x\phi(\pi^\sharp(\widetilde{\phi^*(\alpha)})) = d_x\phi(\pi^\sharp(\phi^*(\tilde{\alpha}))) = \theta^\sharp(\tilde{\alpha}) = \theta_Y^\sharp(\alpha).$$

This shows that ϕ restricts to a Poisson map. \square

Example 5.27. As another application of Proposition 5.26, one can obtain affine Poisson transversals inside a linear Poisson manifold. For this, let $(\mathfrak{g}, [\cdot, \cdot])$ be a Lie algebra, and let $\mathfrak{h} \subset \mathfrak{g}$ be a Lie subalgebra. Assume that $(\mathfrak{h}^*, \pi_{\mathfrak{h}})$ has an open coadjoint orbit, and let $\xi_0 \in \mathfrak{h}^*$ be a point in such an orbit. Then $\{\xi_0\}$ is a Poisson transversal in \mathfrak{h}^* . By applying the proposition to the restriction map $\mathfrak{g}^* \rightarrow \mathfrak{h}^*$, we obtain that the affine subspace

$$X := \{\xi \in \mathfrak{g}^* : \xi|_{\mathfrak{h}} = \xi_0\}$$

is a Poisson transversal in $(\mathfrak{g}^*, \pi_{\mathfrak{g}})$.

For example, if \mathfrak{g} contains a nonabelian Lie subalgebra of dimension 2,

$$\mathfrak{h} = \text{Span}\{u, v\}, \quad [u, v] = u,$$

then \mathfrak{g}^* contains a Poisson transversal of codimension 2,

$$X := \{\xi \in \mathfrak{g}^* : \xi(u) = 1, \xi(v) = 0\}.$$

A more interesting example can be obtained as follows. Let $\mathfrak{g} = \mathfrak{sl}(k+1, \mathbb{R})$, and let \mathfrak{h} be the subalgebra consisting of matrices of the form

$$A = \begin{pmatrix} a_0 & a_1 & \dots & a_k \\ 0 & 0 & \dots & a_{k+1} \\ \dots & \dots & \dots & \dots \\ 0 & 0 & 0 & a_{2k} \end{pmatrix}, \quad a_0 = -a_{2k}.$$

Then one can easily show that the element $\xi_0 \in \mathfrak{h}^*$ defined by

$$\xi_0(A) := a_k$$

belongs to an open coadjoint orbit of \mathfrak{h}^* . The corresponding affine Poisson transversal has codimension $2k$ and is a particular case of a *Slodowy slice*. These are special types of Poisson transversals in duals of complex semi-simple Lie algebra and play an important role in representation theory [73].

Exercise 5.28. For $k = 2$, calculate the induced Poisson structure on the Poisson transversal. 

Example 5.29. Recall that the moment map $\mu : (S, \omega) \rightarrow \mathfrak{g}^*$ of any Hamiltonian G -space is a Poisson map. Hence, for any Poisson transversal $X \subset \mathfrak{g}^*$ the moment map μ is transverse to X and $\mu^{-1}(X)$ is a Poisson transversal in (S, ω) , i.e., a symplectic submanifold. In particular, if X is a slice to a coadjoint orbit, then $\mu^{-1}(X)$ is a symplectic submanifold.

For example, one can take the Poisson transversals (Slodowy slices) discussed in the previous example to obtain symplectic submanifolds in any $SL(k + 1, \mathbb{R})$ -Hamiltonian space. 

Problems

5.1. Let X be any submanifold of a Poisson manifold (M, π) . Prove that

$$(T_x X)^\perp_\pi = (T_x X \cap T_x S)^\perp_{\omega_S}, \quad \forall x \in X,$$

where (S, ω_S) is the symplectic leaf containing x .

5.2. Let (M, π) be a Poisson manifold, and let $X \subset M$ be a Poisson transversal with induced Poisson structure π_X . If $f \in C^\infty(M)$ is a Casimir function for (M, π) , prove that $f|_X$ is a Casimir function for (X, π_X) .

5.3. Give a proof of Theorem 5.22 by mimicking the argument of the usual Moser Lemma from symplectic geometry leafwise.

5.4. Let (M, π) be a Poisson manifold, and let $B \in \Omega^2(M)$ be a closed 2-form.

- (a) Show that the bundle map $I + B^b \circ \pi^\sharp : T^*M \rightarrow T^*M$ is an isomorphism if and only if for every leaf $(S, \omega_S) \in \mathcal{F}_\pi$ the 2-form $\omega_S + B|_S$ is nondegenerate.
- (b) If $I + B^b \circ \pi^\sharp : T^*M \rightarrow T^*M$ is an isomorphism, show that π has a gauge transform $\pi_B = e^B \pi$ by B , given by

$$\pi_B^\sharp = \pi^\sharp \circ (I + B^b \circ \pi^\sharp)^{-1}.$$

5.5. Consider the product of two Poisson manifolds $(S, \omega) \times (W, \pi_W)$, where (S, ω) is a symplectic manifold and $\pi_W \in \mathfrak{X}^2(W)$ is a Poisson structure that vanishes at some point w_0 . Show the following:

- (a) For any smooth function $F : W \rightarrow S$, the submanifold

$$X = \{(F(w), w) : w \in U\} \subset S \times W$$

is a Poisson transversal for some small neighborhood $U \subset W$ of w_0 .

- (b) The projection

$$\phi : X \rightarrow U, \quad (F(w), w) \mapsto w,$$

yields a Poisson diffeomorphism up to a gauge transformation; i.e.,

$$\phi_* \pi_X = e^B \pi_W, \quad \text{with} \quad B = F^* \omega.$$

5.6. Prove the following converse to Proposition 5.26: Let $\phi : (M, \pi) \rightarrow (N, \theta)$ be a Poisson map, and let $Y \subset N$ be a submanifold such that ϕ is transverse to Y . If $X := \phi^{-1}(Y)$ is a Poisson transversal, then there is an open set U containing $\phi(X)$ such that $Y \cap U$ is a Poisson transversal in (N, θ) .

5.7. Let $(\mathfrak{g}, [\cdot, \cdot])$ be a Lie algebra, and let $\xi \in \mathfrak{g}$. Consider an affine slice $\xi + c^\circ$ through ξ , i.e., $c \subset \mathfrak{g}$ is a linear subspace such that $\mathfrak{g} = \mathfrak{g}_\xi \oplus c$, and let $X \subset \xi + c^\circ$ be a neighborhood of ξ which is a Poisson transversal. If c satisfies the condition

$$[\mathfrak{g}_\xi, c] \subset c,$$

show that the translation is a Poisson map

$$\phi : (X, \pi_X) \rightarrow (\mathfrak{g}_\xi^*, \pi_{\mathfrak{g}_\xi^*}), \quad \eta \mapsto (\eta - \xi)|_{\mathfrak{g}_\xi}.$$

5.8. Let X be a Poisson transversal of (M, π) .

- (a) Show that X is co-orientable, i.e., that the line bundle $\bigwedge^{\text{top}} \nu(X)$ has a nowhere vanishing section.

(HINT: The normal bundle $\nu(X)$ is canonically identified with $(TX)^\perp$.)

- (b) Show that if M is orientable, then X is also orientable.

5.9. Consider a smooth family $\{X_t\}_{t \in [0,1]}$ of closed embedded Poisson transversals in (M, π) . Moreover, assume that there exists a smooth family of proper embeddings

$$i : X_0 \times [0, 1] \rightarrow M, \quad (x, t) \mapsto i_t(x),$$

such that $X_t = i_t(X_0)$. Consider also the submanifold

$$\tilde{X} := \{(x, t) : x \in X_t\} \subset M \times [0, 1].$$

For each $(x, t) \in \tilde{X}$, since X_t is a Poisson transversal, we can write

$$\frac{d}{dt}i_t(x_0) = u(x, t) + \pi^\sharp(\alpha(x, t)),$$

where $x = i_t(x_0)$, for unique $u(x, t) \in T_x X_t$ and $\alpha(x, t) \in (T_x X_t)^\circ$.

(a) Prove that there exists a smooth function $H \in C^\infty(M \times [0, 1])$ such that

$$H|_{\tilde{X}} = 0 \quad \text{and} \quad dH|_{\tilde{X}} = \alpha.$$

(b) Prove that the flow of the time-dependent Hamiltonian vector field X_{H_t} , defined as a map $\Phi_{X_H}^{t,s} : M^{t,s} \rightarrow M$, where $M^{t,s} \subset M$ is an open subset, satisfies $\Phi_{X_H}^{t,s}(X_s \cap M^{t,s}) \subset X_t$.

(c) Deduce the following result: if $\{X_t\}_{t \in [0,1]}$ is a smooth family of compact Poisson transversals in a Poisson manifold (M, π) , then there exists a Hamiltonian diffeomorphism $\Phi \in \text{Ham}(M, \pi)$ such that $\Phi(X_0) = X_1$.

(HINT: Look at the proof of Theorem 5.19.)

Symplectic Realizations

We have seen in previous chapters that Poisson structures can exhibit complex behavior: the symplectic foliation can be complicated, leaves wrapping around each other or having different dimensions, singular leaves can have nonabelian isotropy, the symplectic form can vary from leaf to leaf, etc. One possible way around these difficulties is to exhibit the Poisson manifold as some kind of “quotient” of a symplectic manifold. In this chapter, we start discussing such symplectic realizations of Poisson manifolds.

6.1. Definition

Definition 6.1. A **symplectic realization** of a Poisson manifold (M, π) , denoted

$$\mu : (S, \omega) \rightarrow (M, \pi),$$

consists of

- a symplectic manifold (S, ω) ,
- a surjective submersion $\mu : S \rightarrow M$ which is a Poisson map.

Of course, μ is a Poisson map from S endowed with the nondegenerate Poisson structure π_ω obtained by inverting ω . As in Proposition 2.16, this can be expressed as the equation

$$(6.1) \quad \pi^\sharp = (d\mu) \circ \pi_\omega^\sharp \circ (d\mu)^* \quad (\pi_\omega^\sharp = (\omega^\flat)^{-1})$$

or equivalently as the commutativity of the diagram

$$\begin{array}{ccc}
 T_p S & \xrightarrow{d\mu} & T_x M \\
 \pi_\omega^\# \uparrow \downarrow \omega^\flat & & \uparrow \pi^\# \\
 T_p^* S & \xleftarrow{(d\mu)^*} & T_x^* M
 \end{array}$$

for all $p \in S$, where $x := \mu(p)$.

We will show later that any Poisson manifold admits a symplectic realization. Note that given a symplectic realization $\mu : (S, \omega) \rightarrow (M, \pi)$ one can produce more examples of symplectic realizations of the same Poisson manifold by taking products with other symplectic manifolds (S', ω') : the projection

$$(S \times S', \omega \oplus \omega') \rightarrow (M, \pi), \quad (p, p') \mapsto \mu(p),$$

is still a Poisson map, and hence it is also a symplectic realization. This shows that symplectic realizations are far from unique.

Symplectic realizations can be restricted to Poisson transversals:

Proposition 6.2. *If $\mu : (S, \omega) \rightarrow (M, \pi)$ is a symplectic realization then for any Poisson transversal X of M , $S_X := \mu^{-1}(X)$ is a symplectic submanifold and μ restricts to a symplectic realization $\mu : (S_X, \omega|_{S_X}) \rightarrow (X, \pi_X)$.*

Proof. The proposition is an immediate consequence of the following:

- Poisson transversals of symplectic manifolds are the same as symplectic submanifolds (see Exercise 5.3),
- Poisson transversals behave functorially with respect to Poisson maps (see Proposition 5.26). □

The actual search for explicit realizations is very interesting and by no means trivial, even in the simplest cases. This will be illustrated in the next section with several examples. For now, we observe that S cannot be “too small”:

Lemma 6.3. *If (S, ω) is a symplectic realization of (M, π) , then*

$$\dim(S) \geq 2 \dim(M) - \text{rank } \pi_x, \quad \forall x \in M.$$

In particular, if π vanishes at some point, then $\dim(S) \geq 2 \dim(M)$.

Proof. Let $p \in S$, and let $x = \mu(p)$. By the Poisson condition (6.1), we have that $\pi_\omega^\# \circ (d_p \mu)^*$ maps $\text{Ker } \pi_x^\#$ to $\text{Ker } d_p \mu$. Since this map is injective, we obtain the inequality from the statement

$$\dim(M) - \text{rank } \pi_x = \dim(\text{Ker } \pi_x^\#) \leq \dim(\text{Ker } d_p \mu) = \dim(S) - \dim(M). \quad \square$$

Remark 6.4 (Lie's function groups). Poisson structures already appeared in Sophus Lie's work, in the nineteenth century. Lie was interested in understanding (pseudo)groups of contact transformations. He worked on the phase space \mathbb{R}^{2n} and reasoned infinitesimally. For him, the analogue of the group-like property — closed under composition — was then expressed as an infinitesimal property that made use of the canonical Poisson bracket on \mathbb{R}^{2n} . This led Lie to the discovery of his **function groups**. By these he meant a collection $\{\phi_1, \dots, \phi_r\}$ of functionally independent smooth functions, depending on $(q, p) \in \mathbb{R}^{2n}$, with the property that the canonical Poisson brackets $\{\phi_i, \phi_j\}_{\text{can}}$ are of type

$$(6.2) \quad \{\phi_i, \phi_j\}_{\text{can}} = w_{ij}(\phi_1, \dots, \phi_r),$$

for some smooth functions w_{ij} depending on r variables. More generally, one says that a function $\phi = \phi(q, p)$ belongs to the function group generated by the collection $\{\phi_1, \dots, \phi_r\}$ and writes $\phi \in \mathcal{F}(\phi_1, \dots, \phi_r)$ if it is of type $f(\phi_1, \dots, \phi_r)$. In other words, a function group is a subspace

$$\mathcal{F} \subset C^\infty(\mathbb{R}^{2n})$$

with the property that it is closed under the canonical Poisson bracket,

$$\phi, \psi \in \mathcal{F} \implies \{\phi, \psi\}_{\text{can}} \in \mathcal{F},$$

and such that \mathcal{F} is functionally generated by r functionally independent functions ϕ_1, \dots, ϕ_r . An immediate remark is that the functions w_{ij} must be the coefficients of a Poisson bracket on \mathbb{R}^r . Packing things together, a function group induces a Poisson bracket $\{\cdot, \cdot\}_w$ on \mathbb{R}^r and we deal with a submersion

$$\mu = (\phi_1, \dots, \phi_r) : \mathbb{R}^{2n} \rightarrow \mathbb{R}^r$$

that is a Poisson map. Lie also considered the converse problem of reconstructing the function group $\mathcal{F} \subset C^\infty(\mathbb{R}^{2n})$ out of w , and this is precisely the problem of building a symplectic realization. Therefore, in its local version but in full generality, the problem of existence of symplectic realizations goes all the way back to the work of Lie.

6.2. Examples

In view of the submersion theorem, the problem of finding a symplectic realization takes the following form locally. Given a Poisson structure π in local variables (x^1, \dots, x^m) with brackets,

$$\{x^i, x^j\} = \pi^{ij}(x),$$

one needs to define new brackets,

$$\{x^i, u^a\} = \theta^{ia}(x, u), \quad \{u^a, u^b\} = \varphi^{ab}(x, u),$$

which are smooth functions in $(x, u) = (x^1, \dots, x^m, u^1, \dots, u^n)$, such that

$$\Pi = \sum_{i < j} \pi^{ij}(x) \frac{\partial}{\partial x^i} \wedge \frac{\partial}{\partial x^j} + \sum_{i,a} \theta^{ia}(x, u) \frac{\partial}{\partial x^i} \wedge \frac{\partial}{\partial u^a} + \sum_{a < b} \varphi^{ab}(x, u) \frac{\partial}{\partial u^a} \wedge \frac{\partial}{\partial u^b}$$

is *nondegenerate* and a *Poisson structure*. We will give several examples which will reveal the rich geometry behind this problem.

Example 6.5 (Zero Poisson structures). One of the simplest examples is $M = \mathbb{R}^2$ with the trivial (zero) Poisson structure

$$\{x, y\} = 0.$$

A simple way to obtain a symplectic realization is by adding two variables (u, v) and by taking the nondegenerate Poisson structure defined by

$$\{x, u\} = 1, \quad \{y, v\} = 1, \quad \{u, v\} = 0.$$

We are led to discover the canonical symplectic structure ω_{can} on \mathbb{R}^4 as a symplectic realization together with $\mu(x, y, u, v) = (x, y)$.

We can slightly modify this example to obtain a symplectic realization with compact fibers. Namely, we form the quotient of the fibers by \mathbb{Z}^2 ,

$$\mu : (\mathbb{R}^2 \times \mathbb{T}^2, \omega) \rightarrow (\mathbb{R}^2, 0),$$

where $\mu(x, y, \phi_x, \phi_y) = (x, y)$ and $\omega = d\phi_x \wedge dx + d\phi_y \wedge dy$.

More generally, if we consider the zero Poisson structure on an arbitrary manifold M , a symplectic realization is given by the cotangent bundle T^*M endowed with the canonical symplectic structure and the bundle projection:

$$(6.3) \quad \mu : (T^*M, \omega_{\text{can}}) \rightarrow (M, 0).$$

Exercise 6.6. Show that (6.3) is indeed a Poisson map.

A more interesting story reveals itself when one looks for proper symplectic realizations. As in the case of \mathbb{R}^2 , we modify the above example by taking a quotient of T^*M which makes the fibers of μ compact. For this, we consider a **lattice** on M :

$$\Lambda \subset T^*M.$$

By this we mean that $\Lambda = \bigcup_{x \in M} \Lambda_x$ with the following:

- For each $x \in M$, a discrete subgroup Λ_x of T_x^*M of rank $m = \dim M$. In particular $\Lambda_x \simeq \mathbb{Z}^m$. Such a subgroup of a vector space V is called a *lattice* in the vector space V .
- The family $\{\Lambda_x\}_{x \in M}$ varies smoothly, in the sense that every $x \in M$ has a neighborhood U on which there exist 1-forms $\alpha^1, \dots, \alpha^m \in \Omega^1(U)$ such that, for all $y \in U$, $\alpha^1|_y, \dots, \alpha^m|_y$ forms a \mathbb{Z} -basis of the abelian group Λ_y .

Given such a lattice one can form the quotient

$$\mathcal{T}_\Lambda := T^*M/\Lambda,$$

which will be a fiber bundle over M with fibers the tori T_x^*M/Λ_x .

Exercise 6.7. Prove the following:

- (a) A lattice $\Lambda \subset T^*M$ induces a flat connection ∇^Λ on the vector bundle T^*M such that its local flat sections are \mathbb{R} -linear combinations of local sections in Λ .
- (b) The 2-sphere \mathbb{S}^2 does not admit a lattice.
(HINT: \mathbb{S}^2 is simply connected.)

For a lattice Λ on M , the induced projection $\mu_\Lambda : \mathcal{T}_\Lambda \rightarrow M$ is a proper map. For ω_{can} to descend to a 2-form on the bundle \mathcal{T}_Λ , one needs another condition on Λ :

Proposition 6.8. *Consider a lattice $\Lambda \subset T^*M$, and let $p : T^*M \rightarrow \mathcal{T}_\Lambda$ be the projection. There exists a 2-form*

$$\omega_\Lambda \in \Omega^2(\mathcal{T}_\Lambda)$$

such that $p^\omega_\Lambda = \omega_{\text{can}}$ if and only if any local section of Λ is a closed 1-form.*

Proof. Note that both conditions are local. Therefore, we may restrict to connected open subsets $U \subset M$ on which there exist linearly independent 1-forms $\alpha^1, \dots, \alpha^m$ that form a basis for Λ_x for any $x \in U$. Then the action

$$\mathbb{Z}^m \times T^*U \rightarrow T^*U, \quad (k_1, \dots, k_m) \cdot \alpha = \alpha + k_1\alpha^1 + \dots + k_m\alpha^m,$$

is free and proper and $\mathcal{T}_\Lambda|_U = T^*U/\mathbb{Z}^m$.

We have that ω_{can} descends to $\mathcal{T}_\Lambda|_U$, i.e., there exists $\omega_\Lambda \in \Omega^2(\mathcal{T}_\Lambda|_U)$ such that $p^*\omega_\Lambda = \omega_{\text{can}}$, if and only if ω_{can} is \mathbb{Z}^m -invariant. Note that

$$(k_1, \dots, k_m)^*\omega_{\text{can}} = \omega_{\text{can}} + \sum_{i=1}^m k_i(\alpha^i)^*\omega_{\text{can}} = \omega_{\text{can}} - \sum_{i=1}^m k_i d\alpha^i.$$

Thus ω_{can} is \mathbb{Z}^m -invariant if and only if the 1-forms $\sum_{i=1}^m k_i\alpha^i$ are closed, for $(k_1, \dots, k_m) \in \mathbb{Z}^m$. Since these are all section of $\Lambda|_U$, the claim follows. \square

A lattice $\Lambda \subset T^*M$ has the property that all its local sections are closed if and only if Λ is locally spanned by closed 1-forms. Such a lattice is called an **integrable lattice**. Here are other characterizations of such lattices:

Exercise 6.9. Let $\Lambda \subset T^*M$ be a lattice. Denote by ∇^Λ the connection on TM dual to the connection on T^*M from Exercise 6.7. Also denote by Λ^\vee the dual lattice on TM :

$$\Lambda_x^\vee := \{X \in T_xM : \alpha(X) \in \mathbb{Z}, \forall \alpha \in \Lambda_x\}.$$

Show that the following are equivalent:

- (a) Λ is an integrable lattice.
- (b) The Lie bracket of any two local sections of Λ^\vee is zero.
- (c) ∇^Λ is torsion-free.
- (d) Λ is a Lagrangian submanifold of $(T^*M, \omega_{\text{can}})$.

We will see in Section 12.7 that integrable lattices codify *integral affine structures* on a manifold. 

Example 6.10 (Constant Poisson structures). Consider the constant Poisson structure on \mathbb{R}^3 with structure functions

$$\{x, y\} = 1, \quad \{y, z\} = 1, \quad \{z, x\} = 1.$$

We look for 4-dimensional, constant symplectic realizations. We introduce a new variable u and extend the previous Poisson brackets by constant ones:

$$\{x, u\} = a, \quad \{y, u\} = b, \quad \{z, u\} = c.$$

We only need to ensure nondegeneracy, which holds as long as $a + b + c \neq 0$.

More generally, consider a constant Poisson structure on a vector space V , given by a bivector

$$\pi_V \in \bigwedge^2 V,$$

interpreted as a constant bivector field on V as in Subsection 2.4.5. Of course, we may assume that $V = \mathbb{R}^n$, but it is instructive to have a coordinate-free discussion. As in the 3-dimensional case, we look for a *constant* symplectic realization

$$\mu : (\tilde{V}, \omega_{\tilde{V}}) \rightarrow (V, \pi_V),$$

i.e., \tilde{V} is a vector space endowed with a nondegenerate 2-form $\omega_{\tilde{V}} \in \bigwedge^2 \tilde{V}^*$, whose inverse is a constant bivector $\pi_{\tilde{V}} \in \bigwedge^2 \tilde{V}$. In the case of the zero bivector $\pi_V = 0$, the previous discussion shows that we can take

$$T^*V := V \oplus V^*, \quad \text{with} \quad \omega_{\text{can}}((v, \alpha), (w, \beta)) = \beta(v) - \alpha(w),$$

and μ the projection onto the first factor.

For the general case, we can use Proposition 2.24: π_V is encoded by the subspace $W := \pi_V^\sharp(V^*)$ and a nondegenerate 2-form $\omega_W \in \bigwedge^2 W^*$ given by

$$\omega_W(\pi_V^\sharp \alpha, \pi_V^\sharp \beta) = -\pi_V(\alpha, \beta).$$

Hence, if we choose a complement C to W in V , we have

$$(V, \pi_V) = (W, \omega_W^{-1}) \times (C, 0),$$

and one obtains the desired symplectic realization as a product:

$$(\tilde{V}, \omega_{\tilde{V}}) := (W, \omega_W) \times (T^*C, \omega_{\text{can}}).$$

Hence, $\tilde{V} = V \oplus C^*$, with μ the projection onto the first factor. For instance, in the example we started with, W is the hyperplane of \mathbb{R}^3 given by the equation $x + y + z = 0$ and the choice of the constants a, b, c there encoded the choice of a complement C .

Notice that if we don't insist on constructing a symplectic realization of *minimal* dimension, we can find a natural symplectic realization of *double* dimension. Namely, we now consider the symplectic manifold $S = V \oplus V^*$ with symplectic form

$$\omega((u, \xi), (v, \eta)) = \langle u, \eta \rangle - \langle v, \xi \rangle + \pi_V(\xi, \eta),$$

where $(u, \xi), (v, \eta) \in V \oplus V^*$ and the Poisson map μ is the projection to V .

Exercise 6.11. Show that one can choose canonical coordinates so that this symplectic realization becomes

$$\mu : \left(\mathbb{R}^{2n}, \sum_{i=1}^n dp_i \wedge dq^i \right) \rightarrow (\mathbb{R}^n, \pi_V), \quad \mu^i(q, p) = q^i - \frac{1}{2} \sum_{j=1}^n \pi_V^{ij} p_j. \quad \curvearrowright$$

Example 6.12 (LV-type Poisson structures). Let us now turn to the quadratic Poisson structures of LV-type of Example 1.28. We start by looking in dimension 2 and consider the quadratic Poisson structure on \mathbb{R}^2 :

$$\{x, y\} = xy.$$

Again, a symplectic realization can be found by adding two new variables:

$$\{u, v\} = uv, \quad \{x, u\} = 1, \quad \{y, v\} = 1, \quad \{x, v\} = -xv, \quad \{y, u\} = yu.$$

This defines a nondegenerate Poisson structure on \mathbb{R}^4 for which the projection $\mu(x, y, u, v) = (x, y)$ is Poisson and with corresponding symplectic form given by

$$(6.4) \quad \omega = d(xu) \wedge d(yv) - dx \wedge du - dy \wedge dv.$$

Exercise 6.13. Show that this Poisson bracket admits the following symmetries:

- (a) A Poisson automorphism of order 4:

$$(x, y, u, v) \mapsto (-u, -v, x, y).$$

- (b) An anti-Poisson involution:

$$(x, y, u, v) \mapsto (-v, -u, -y, -x).$$

- (c) An anti-Poisson involution:

$$(x, y, u, v) \mapsto (xe^{yv}, ye^{-xu}, -ue^{-yv}, -ve^{xu}).$$

Exercise 6.14. Check that the map $\mu : \mathbb{R}^4 \rightarrow \mathbb{R}^2$ given by

$$(x, y, u, v) \mapsto (xe^{yv}, ye^{-xu})$$

is a symplectic realization of $\{x, y\} = -xy$, where \mathbb{R}^4 is equipped with the symplectic structure (6.4).

Note that, for each $a \in \mathbb{R}$, the Poisson structure

$$\{x, y\} = axy$$

admits a symplectic realization $\mu : \mathbb{R}^4 \rightarrow \mathbb{R}^2$, $(x, y, u, v) \mapsto (x, y)$, with

$$(6.5) \quad \{u, v\} = a uv, \quad \{x, v\} = -a xv, \quad \{y, u\} = a yu, \quad \{y, v\} = \{x, u\} = \varepsilon,$$

for each nonzero value of the parameter ε — at $\varepsilon = 0$ we obtain a nonsymplectic Poisson structure. The corresponding symplectic form is

$$\omega = \frac{1}{\varepsilon^2} (a \, d(xu) \wedge d(yv) - \varepsilon \, dx \wedge du - \varepsilon \, dy \wedge dv).$$

Moving now to arbitrary dimension, consider a general LV-type Poisson structure on \mathbb{R}^n , determined by the skew-symmetric matrix $A = (a^{ij})$:

$$\{x^i, x^j\} = a^{ij} x^i x^j.$$

On the open set $\mathbb{R}_{>0}^n$ we can obtain a symplectic realization of any such quadratic Poisson structure by first making the change of coordinates $x^i = e^{\tilde{x}^i}$, which transforms the bracket into the constant Poisson bracket

$$\{\tilde{x}^i, \tilde{x}^j\} = a^{ij},$$

and then use the theory for constant Poisson structures. For instance, we can obtain a symplectic realization of double dimension, as in Exercise 6.11 — in which case we recover the formulas of Exercise 1.31. We can also obtain a symplectic realization of minimal dimension $\mu : \mathbb{R}^{2k} \rightarrow \mathbb{R}_{>0}^n$, where $2k = 2n - \text{rank } A$.

If we want a symplectic realization on the whole of \mathbb{R}^n , the minimal dimension is $2n$. One can find such a realization by duplicating the number of variables. The projection $\mathbb{R}^{2n} \rightarrow \mathbb{R}^n$, $(x, u) \mapsto x$, is a symplectic realization if we equip \mathbb{R}^{2n} with the nondegenerate Poisson bracket

$$(6.6) \quad \begin{aligned} \{x^i, x^j\} &= a^{ij} x^i x^j, & \{u^i, u^j\} &= a^{ij} u^i u^j, \\ \{x^i, u^j\} &= -a^{ij} x^i u^j \quad (i \neq j), & \{x^i, u^i\} &= 1. \end{aligned}$$

We will see later that this symplectic realization has a deep geometric relationship with the original Poisson structure.

Exercise 6.15. Check that the bracket (6.6) satisfies the Jacobi identity and is nondegenerate. Find the corresponding symplectic form. 

Example 6.16 (Quadratic Poisson structures on \mathbb{R}^2). We can also use the discussion in the previous example to treat quadratic — not necessarily of LV-type — Poisson structures on \mathbb{R}^2 . For example, consider the Poisson structure

$$\{x, y\} = x^2 + y^2.$$

The Poisson geometry of this structure is quite different from the one in the previous example — think about its singular locus! However, one can take advantage of its algebraic nature using the basic identity

$$x^2 + y^2 = (x + iy)(x - iy).$$

This suggests considering the symplectic realization (6.5) and rebaptizing the coordinates to z_1, z_2, ξ_1, ξ_2 , so that (6.5) becomes

$$\begin{aligned} \{z_1, z_2\} &= a z_1 z_2, & \{z_1, \xi_1\} &= \varepsilon, & \{z_2, \xi_1\} &= a z_2 \xi_1, \\ \{\xi_1, \xi_2\} &= a \xi_1 \xi_2, & \{z_1, \xi_2\} &= -a z_1 \xi_2, & \{z_2, \xi_1\} &= \varepsilon. \end{aligned}$$

The constants a and ε are still to be chosen. We would like to add to x and y new variables u and v to build a symplectic realization. So we now proceed formally and assume that all the variables involved (x, u, z_1, ξ_1, \dots) are complex. This allows us to postulate the following relations between them, which we view as a simple complex change of coordinates:

$$z_1 = x + iy, \quad z_2 = x - iy, \quad \xi_1 = u + iv, \quad \xi_2 = u - iv.$$

If we compute the Poisson brackets involving x, y, u, v using the previous relations, we see that we should set $a = -2i$. We obtain

$$(6.7) \quad \begin{aligned} \{x, y\} &= x^2 + y^2, & \{x, u\} &= \frac{\varepsilon}{2} + (xv - yu), & \{y, u\} &= (yv + xu), \\ \{u, v\} &= u^2 + v^2, & \{x, v\} &= -(yv + xu), & \{y, v\} &= -\frac{\varepsilon}{2} + (xv - yu). \end{aligned}$$

One can check directly that, indeed, this defines a symplectic realization of the original Poisson structure.

Such a trick will not work for a general Poisson structure on \mathbb{R}^2 :

$$\{x, y\} = \pi_{xy}.$$

If we look for a symplectic realization with projection $\mu : \mathbb{R}^4 \rightarrow \mathbb{R}^2$ and Poisson bracket,

$$\begin{aligned} \{x, y\} &= \pi_{xy}, & \{x, u\} &= \pi_{xu}, & \{y, u\} &= \pi_{yu}, \\ \{u, v\} &= \pi_{uv}, & \{x, v\} &= \pi_{xv}, & \{y, v\} &= \pi_{yv}, \end{aligned}$$

we need $\pi \wedge \pi \neq 0$. For this, we make the *ansatz*

$$(6.8) \quad \pi_{uv}\pi_{xy} + \pi_{xv}\pi_{yu} - \pi_{xu}\pi_{yv} = c,$$

with $c \in \mathbb{R}$ a nonzero constant. The corresponding 2-form will be given by

$$\omega = \frac{1}{c} (-\pi_{uv}dx \wedge dy - \pi_{xy}du \wedge dv + \pi_{yv}dx \wedge du - \pi_{yu}dx \wedge dv - \pi_{xv}dy \wedge du + \pi_{xu}dy \wedge dv).$$

This is a relatively simple formula, e.g., polynomial, if π is polynomial. Also, the Poisson condition amounts to $d\omega = 0$; i.e.,

$$\begin{aligned} \frac{\partial \pi_{uv}}{\partial u} + \frac{\partial \pi_{yv}}{\partial y} + \frac{\partial \pi_{xv}}{\partial x} &= 0, & \frac{\partial \pi_{yx}}{\partial x} + \frac{\partial \pi_{yv}}{\partial v} + \frac{\partial \pi_{yu}}{\partial u} &= 0, \\ \frac{\partial \pi_{vu}}{\partial v} + \frac{\partial \pi_{yu}}{\partial y} + \frac{\partial \pi_{xu}}{\partial x} &= 0, & \frac{\partial \pi_{xy}}{\partial y} + \frac{\partial \pi_{xv}}{\partial v} + \frac{\partial \pi_{xu}}{\partial u} &= 0. \end{aligned}$$

Hence, starting with a quadratic — or, more generally, polynomial — function π_{xy} , one can look for polynomial functions π_{xu} , π_{xv} , π_{yu} , π_{yv} , and π_{uv} satisfying the algebraic equation (6.8) and then replace them in this linear system of PDEs. The nature of equation (6.8) is such that it already gives an indication of the unknown functions.

For example, for the realization of $\pi_{xy} = x^2 + y^2$ that we have seen above, (6.8) becomes

$$(x^2 + y^2)\pi_{uv} + \pi_{xv}\pi_{yu} - \pi_{xu}\pi_{yv} = 1,$$

and we have found the solutions $\pi_{uv} = u^2 + v^2$, $\pi_{yu} = yv + xu = -\pi_{xv}$, $\pi_{xu} = -1 + xv - yu$, and $\pi_{yv} = 1 + xv - yu$.

Here are a couple of other examples:

- $\{x, y\} = x^2 - y^2$ for which we find the symplectic realization

$$\begin{aligned} \{x, y\} &= x^2 - y^2, & \{x, u\} &= 1 - (xv - yu), & \{y, u\} &= xu - yv, \\ \{u, v\} &= u^2 - v^2, & \{x, v\} &= -xu + yv, & \{y, v\} &= 1 + (xv - yu), \end{aligned}$$

with the corresponding symplectic form

$$\omega = (u^2 - v^2)dx \wedge dy + (x^2 - y^2)du \wedge dv - (1 + xv - yu)dx \wedge du + (xu - yv)dx \wedge dv + (-xu + yv)dy \wedge du - (1 - xv + yu)dy \wedge dv.$$

- $\{x, y\} = x^2$ for which we find the symplectic realization

$$\begin{aligned} \{x, y\} &= x^2, & \{x, u\} &= 1 + xv, & \{y, u\} &= xu + yv, \\ \{u, v\} &= v^2, & \{x, v\} &= 0, & \{y, v\} &= -1 + xv, \end{aligned}$$

with the corresponding symplectic form

$$\omega = -v^2dx \wedge dy - x^2du \wedge dv + (-1 + xv)dx \wedge du - (xu + yv)dx \wedge dv + (1 + xv)dy \wedge dv.$$



6.3. Symplectic realizations of linear Poisson structures

You may have noticed that we left out the case of linear Poisson structures in the list of examples in the previous section. On the one hand, finding symplectic realizations of linear Poisson structures will give us fundamental geometric insight that will eventually lead us to the solution of the general problem of building symplectic realizations. On the other hand, unlike other cases, in the linear case we do have a complete solution to this problem. For both of these reasons, we devote this entire section to this case.

In order to get some intuition, let us consider first the linear Poisson structure on \mathbb{R}^2 associated with the nonabelian, 2-dimensional Lie algebra $\mathfrak{g} = \mathfrak{aff}(1, \mathbb{R})$:

$$\{x, y\} = x.$$

Since the Poisson structure vanishes at the origin, the smallest possible dimension of a symplectic realization is 4. So we consider the map

$$(6.9) \quad \mu : \mathbb{R}^4 \rightarrow \mathbb{R}^2, \quad (x, y, u, v) \mapsto (x, y),$$

and look for a nondegenerate Poisson bracket on \mathbb{R}^4 for which μ is a Poisson map. To find a solution, we make a simple *ansatz*: the only nonzero structure functions are $\{x, y\} = x$ (a must), $\{y, v\} = 1$ (as above), and $\{x, u\} = \phi$ (a function to be determined). Then one finds that the Jacobi identity is satisfied if $\phi = e^{-v}$ and so one obtains the following Poisson bracket on \mathbb{R}^4 :

$$\{x, y\} = x, \quad \{x, u\} = e^{-v}, \quad \{y, v\} = 1, \quad \{x, v\} = \{y, u\} = \{u, v\} = 0.$$

A straightforward computation shows that the underlying bivector is nondegenerate and the corresponding symplectic form is

$$(6.10) \quad \omega = e^v (du \wedge dx + xdu \wedge dv) + dv \wedge dy.$$

Observe that the symplectic form on $\mathbb{R}^4 = \mathbb{R}^2 \times \mathbb{R}^2$ can be written as

$$(6.11) \quad \omega = -d(x\theta_1 + y\theta_2),$$

where $\theta_1 = e^v du$, $\theta_2 = dv$. These form a coframe on \mathbb{R}^2 and satisfy

$$(6.12) \quad d\theta_1 = -\theta_1 \wedge \theta_2, \quad d\theta_2 = 0.$$

Exercise 6.17. Let $\{\theta_1, \theta_2\}$ be a coframe on a 2-manifold N that satisfies the *structure equations* (6.12). Show that $\mu : \mathbb{R}^2 \times N \rightarrow \mathbb{R}^2$ with the form (6.11) defines a symplectic realization of the linear Poisson structure $\{x, y\} = x$.

Exercise 6.18. Let G be a Lie group with Lie algebra $\mathfrak{g} = \mathfrak{aff}(1, \mathbb{R})$. Let $\{e^1, e^2\}$ be a basis of \mathfrak{g} such that

$$[e^1, e^2] = e^1.$$

Identify e^1 and e^2 with left-invariant vector fields on G and denote by θ_1 and θ_2 the dual left-invariant 1-forms

$$\theta_i(e^j) = \delta_i^j.$$

Show that the coframe $\{\theta_1, \theta_2\}$ on G satisfies the *structure equations* (6.12).

Let us consider another concrete example of a linear Poisson structure, before dealing with the general case. Namely, consider the linear Poisson structure on \mathbb{R}^3 associated with the Lie algebra $\mathfrak{su}(2) \simeq \mathfrak{so}(3, \mathbb{R})$:

$$\{x^1, x^2\} = x^3, \quad \{x^2, x^3\} = x^1, \quad \{x^3, x^1\} = x^2.$$

Analogous to the previous 2-dimensional example, assume that we can find a 3-dimensional manifold N with a coframe $\{\theta_1, \theta_2, \theta_3\}$ satisfying the *structure equations*:

$$(6.13) \quad d\theta_1 = -\theta_2 \wedge \theta_3, \quad d\theta_2 = -\theta_3 \wedge \theta_1, \quad d\theta_3 = -\theta_1 \wedge \theta_2.$$

Then we have the symplectic manifold

$$S := N \times \mathbb{R}^3, \quad \omega := -d(x^1\theta_1 + x^2\theta_2 + x^3\theta_3) \in \Omega^2(S)$$

and the projection $\mu : S \rightarrow \mathbb{R}^3$ is easily seen to be a symplectic realization of the linear Poisson bracket above. The next exercise shows that one can take $N = \mathbb{S}^3$, so obtaining a proper symplectic realization $\mu : \mathbb{S}^3 \times \mathbb{R}^3 \rightarrow \mathbb{R}^3$.

Exercise 6.19. Let $N = \mathbb{S}^3 \subset \mathbb{R}^4$ be the 3-sphere $u^2 + v^2 + s^2 + t^2 = 1$. Consider the following 1-forms on \mathbb{S}^3 :

$$\begin{aligned} \theta_1 &:= -vdu + udv + tds - sdt, \\ \theta_2 &:= -sdu - tdv + uds + vdt, \\ \theta_3 &:= -tdu + sdv - vds + udt. \end{aligned}$$

Check that this is a coframe satisfying the structure equations (6.13). Moreover, show that under the identification $SU(2) \simeq \mathbb{S}^3$ this coframe is formed by left-invariant 1-forms.

The previous two examples show that in the search for a symplectic realization of $(\mathfrak{g}^*, \pi_{\mathfrak{g}})$ one is inevitably led to the problem of integrating the Lie algebra \mathfrak{g} to a Lie group G . We have already mentioned that Sophus Lie's search for a function group associated to a Poisson structure on \mathbb{R}^n is tantamount to the problem of finding a symplectic realization (see Remark 6.4). Lie was especially interested in the linear case, but because at his time the abstract concept of Lie group was not available, even that was hard to do explicitly, as it amounts to integrating a Lie algebra. In modern language, one needs to find a G -Hamiltonian space

$$\mu : (M, \omega) \rightarrow \mathfrak{g}^*$$

for which the moment map μ is a submersion or, equivalently, for which the infinitesimal action is free — see the correspondence in Example 1.35. One can further narrow down the search by looking for Hamiltonian spaces which are cotangent lifts in the sense of Example B.17,

$$\mu : (T^*N, \omega_{\text{can}}) \rightarrow \mathfrak{g}^*.$$

Since we would like the G -action on N to be free and proper, the most natural choice is $N = G$ with the left action by right translations (see Example B.21):

$$\mathcal{A} : G \times G \rightarrow G, \quad (g, h) \mapsto hg^{-1}.$$

In this case one finds the symplectic realization

$$(6.14) \quad \mu : (T^*G, \omega_{\text{can}}) \rightarrow (\mathfrak{g}^*, \pi_{\mathfrak{g}}), \quad \mu(\alpha) := L_g^*\alpha, \quad \alpha \in T_g^*G.$$

Let us try to be more explicit, by avoiding the use of Lie groups, and experience some of the difficulties that Lie faced. Using left translations, we obtain the identification

$$(6.15) \quad l : T^*G \xrightarrow{\sim} G \times \mathfrak{g}^*, \quad T_g^*G \ni \alpha \mapsto (g, L_g^*\alpha),$$

under which the lifted cotangent action becomes

$$\tilde{\mathcal{A}} : G \times (G \times \mathfrak{g}^*) \rightarrow G \times \mathfrak{g}^*, \quad (g, (h, \alpha)) \mapsto (hg^{-1}, \text{Ad}_g^*\alpha)$$

and the moment map, i.e., the symplectic realization, becomes the projection

$$(6.16) \quad \text{pr}_{\mathfrak{g}^*} : (G \times \mathfrak{g}^*, l_*\omega_{\text{can}}) \rightarrow \mathfrak{g}^*.$$

This agrees with what we saw above, where we tried to enlarge our Poisson spaces (the space \mathfrak{g}^*) by adding extra variables (the G -term). In order to explain the formula we found for the symplectic form, we recall the left-invariant Maurer-Cartan form on the Lie group — see Section A.1:

$$\theta_G \in \Omega^1(G, \mathfrak{g}), \quad \theta_G(v) = dL_{g^{-1}}(v), \quad v \in T_gG.$$

Then we can regard θ_G as a 1-form on $G \times \mathfrak{g}^*$ as follows:

$$\tilde{\theta}_G|_{(g, \xi)} := \langle \xi, \theta_G|_g \circ d\text{pr}_G \rangle \in T_{(g, \xi)}^*(G \times \mathfrak{g}^*).$$

We have the following:

Lemma 6.20. *The 1-form $\tilde{\theta}_G \in \Omega^1(G \times \mathfrak{g}^*)$ is related to the Liouville 1-form $\theta_L \in \Omega^1(T^*G)$ by*

$$(6.17) \quad l_*(\theta_L) = \tilde{\theta}_G.$$

Proof. Let $\alpha \in T_g^*G$. From the definitions, we have that

$$\begin{aligned} l^*(\tilde{\theta}_G)|_{\alpha} &= \langle L_g^*(\alpha), \theta_G|_g \circ d\text{pr}_G \circ dl \rangle \\ &= \langle L_g^*(\alpha), dL_{g^{-1}} \circ dp \rangle = \alpha \circ dp = \theta_L|_{\alpha}, \end{aligned}$$

where $p : T^*G \rightarrow G$ denotes the projection. □

To write this more explicitly, let $\{e^1, \dots, e^n\}$ be a basis of \mathfrak{g} . Then

$$\tilde{\theta}_G = \sum_{k=1}^n x^k \theta_k \in \Omega^1(G \times \mathfrak{g}^*),$$

where the θ_k are the components of the Maurer-Cartan form $\theta_G = \sum_k \theta_k \otimes e^k$ and the x^k are the linear coordinates on \mathfrak{g}^* relative to the fixed basis — strictly speaking, the pullbacks along the projections $G \times \mathfrak{g}^* \rightarrow G$ and $G \times \mathfrak{g}^* \rightarrow \mathfrak{g}^*$, respectively. Therefore, using the Maurer-Cartan equation (see (A.4)),

$$d\theta_G + \frac{1}{2}[\theta_G, \theta_G] = 0,$$

we obtain the following explicit formula for the symplectic realization of the linear Poisson structure:

$$l_*(\omega_{\text{can}}) = l_*(-d\theta_L) = - \sum_k dx_k \wedge \theta^k + \frac{1}{2} \sum_{ijk} x_k c_{ij}^k \theta^i \wedge \theta^j.$$

Actually, the previous discussion relies only on the Maurer-Cartan form or, more precisely, on the Maurer-Cartan equation. This type of form and equations can be found in other parts of geometry under the following more general version:

Definition 6.21. A **Maurer-Cartan form** on a manifold N with values in a Lie algebra \mathfrak{g} is any 1-form $\theta \in \Omega^1(N, \mathfrak{g})$ satisfying:

$$(6.18) \quad d\theta + \frac{1}{2}[\theta, \theta] = 0.$$

We call θ a **strict Maurer-Cartan form** if it is a pointwise isomorphism.

Note that in (6.18) we are using the convention that the Lie bracket of $\theta, \eta \in \Omega^1(N, \mathfrak{g})$ is the \mathfrak{g} -valued 2-form $[\theta, \eta] \in \Omega^2(N, \mathfrak{g})$ defined by

$$[\theta, \eta](X, Y) = [\theta(X), \eta(Y)] - [\theta(Y), \eta(X)], \quad X, Y \in \mathfrak{X}(N).$$

The condition that θ is strict means that $\theta_x : T_x N \rightarrow \mathfrak{g}$ is a linear isomorphism at each $x \in N$. In a basis $\{e^k\}$ of \mathfrak{g} , we can write

$$(6.19) \quad \theta = \theta_1 \otimes e^1 + \dots + \theta_n \otimes e^n, \quad \text{with } \theta_i \in \Omega^1(N),$$

and then (6.18) amounts to the explicit set of equations (A.4).

Exercise 6.22. Consider an n -dimensional Lie algebra \mathfrak{g} with basis $\{e^k\}$ and an n -dimensional manifold N . For $\theta = \sum_k \theta_k \otimes e^k \in \Omega^1(N, \mathfrak{g})$ let

$$\tilde{\theta} = \sum_{k=1}^n x^k \theta_k \in \Omega^1(N \times \mathfrak{g}^*),$$

where the (x^k) are the coordinates on \mathfrak{g}^* induced by the fixed basis. Show that

$$\mathrm{pr}_{\mathfrak{g}^*} : (N \times \mathfrak{g}^*, -d\tilde{\theta}) \rightarrow (\mathfrak{g}^*, \pi_{\mathfrak{g}})$$

is a symplectic realization if and only if θ is a strict Maurer-Cartan element.

To eliminate completely the reference to the Lie group, one observes that there is an explicit well-known formula — see, e.g., [61] or [138] — for the pullback of the Maurer-Cartan form θ_G via the exponential map $\exp : \mathfrak{g} \rightarrow G$; namely,

$$(\exp^* \theta_G)(v) = \int_0^1 e^{-t \mathrm{ad}_v} dt.$$

In this formula, the right-hand side is a linear map $\mathrm{Lin}(\mathfrak{g}, \mathfrak{g})$. Using the canonical identification $T_v \mathfrak{g} \simeq \mathfrak{g}$, we interpret it as a linear map $T_v \mathfrak{g} \rightarrow \mathfrak{g}$. This leads to a formula for the pullback of $l_*(\theta_L)$ under the map $(\exp \times \mathrm{Id}) : \mathfrak{g} \times \mathfrak{g}^* \rightarrow G \times \mathfrak{g}^*$; namely,

$$(6.20) \quad \Theta = (\exp \times \mathrm{Id})^* l_*(\theta_L), \quad \Theta_{(v, \xi)}(w, \eta) = \int_0^1 \xi(e^{-t \mathrm{ad}_v} w) dt.$$

Hence, we obtain a symplectic realization if we restrict $\mathrm{pr}_{\mathfrak{g}^*} : \mathfrak{g} \times \mathfrak{g}^* \rightarrow \mathfrak{g}^*$ to an open neighborhood of $\{0\} \times \mathfrak{g}^*$ where the exponential map is injective. This was precisely the type of solutions found by Sophus Lie.

Exercise 6.23. Show that the resulting symplectic form $\omega = -d\Theta$ on $\mathfrak{g} \times \mathfrak{g}^*$ can be written in the form

$$(6.21) \quad \omega = - \int_0^1 (\phi^{-t})^* \omega_{\mathrm{can}} dt$$

where

$$\phi^t(v, \xi) = (v, e^{-t \mathrm{ad}_v^*} \xi) = (v, \phi_{X_{f_v}}^t(\xi))$$

is the Hamiltonian isotopy associated with $f_{-v} : \mathfrak{g}^* \rightarrow \mathbb{R}$, $\xi \mapsto -\xi(v)$, and ω_{can} is the canonical symplectic form on $T^* \mathfrak{g}^* = \mathfrak{g} \times \mathfrak{g}^*$:

$$\omega_{\mathrm{can}}((v_1, \xi_1), (v_2, \xi_2)) = \langle \xi_1, v_2 \rangle - \langle \xi_2, v_1 \rangle,$$

for $(v_i, \xi_i) \in \mathfrak{g} \oplus \mathfrak{g}^* \simeq T_{(v, \xi)}(\mathfrak{g} \times \mathfrak{g}^*)$.

Remark 6.24. The Maurer-Cartan form $\theta_G \in \Omega^1(G, \mathfrak{g})$ of a Lie group is not only the basic example but also the universal one: any Maurer-Cartan form $\theta \in \Omega^1(N, \mathfrak{g})$ arises, at least locally, as the pullback of θ_G via a smooth map from N to G . Moreover, when θ is strict and one fixes an “origin” $e \in N$, then one can show that a neighborhood of e inherits a *local* Lie group structure with Lie algebra \mathfrak{g} .

Example 6.25 (Affine Poisson structures). A slight twist of the previous discussion on linear Poisson structures allows us to treat affine Poisson structures. Recall from Subsection 2.4.7 that each such structure is associated to a Lie algebra \mathfrak{g} together with a 2-cocycle λ . Their symplectic realizations are related to the notion of **weak G -Hamiltonian space**: such a space, like an ordinary Hamiltonian space, has a moment map

$$\mu : (S, \omega) \rightarrow \mathfrak{g}^*$$

but one gives up on the condition that μ is G -equivariant — and similarly for the notion of weak **\mathfrak{g} -Hamiltonian space**.

At the infinitesimal level, the failure of G -equivariance for a weak Hamiltonian space means that the expressions

$$\mathcal{L}_{a(u)}\mu_v - \mu_{[u,v]} \in C^\infty(S) \quad (u, v \in \mathfrak{g})$$

may be nonzero. However, the moment map condition implies the following:

- The differential of these functions is zero.
- These expressions are antisymmetric in u and v .

Therefore, assuming that S is connected, we obtain a bilinear map

$$(6.22) \quad \lambda : \mathfrak{g} \times \mathfrak{g} \rightarrow \mathbb{R}, \quad \lambda(u, v) := \mathcal{L}_{a(u)}\mu_v - \mu_{[u,v]}.$$

We leave it as an exercise to show the following:

- (a) λ is a 2-cocycle.
- (b) μ becomes a Poisson map when \mathfrak{g}^* is endowed with the affine Poisson structure $\pi_{\mathfrak{g},\lambda}$ associated to λ .
- (c) Conversely, given a 2-cocycle λ on the Lie algebra \mathfrak{g} and a Poisson map $\mu : (S, \omega) \rightarrow (\mathfrak{g}^*, \pi_{\mathfrak{g},\lambda})$, one has an induced infinitesimal action of \mathfrak{g} on S turning it into a weak \mathfrak{g} -Hamiltonian space.

Returning to the question of finding symplectic realizations for the affine Poisson structure associated to (\mathfrak{g}, λ) , one is faced with the problem of finding weak Hamiltonian G -spaces for which the induced 2-cocycle on \mathfrak{g} is precisely λ and $\mu : (S, \omega) \rightarrow \mathfrak{g}^*$ is a submersion. For that we can consider the central extension $\tilde{\mathfrak{g}}_\lambda = \mathfrak{g} \oplus \mathbb{R}$ associated with λ — as in Subsection 2.4.8 — for which we already know how to construct a symplectic realization:

$$\tilde{\mu} : (\tilde{S}, \tilde{\omega}) \rightarrow \tilde{\mathfrak{g}}_\lambda^*.$$

It is straightforward to check that the inclusion

$$(\mathfrak{g}^*, \pi_{\mathfrak{g},\lambda}) \hookrightarrow (\tilde{\mathfrak{g}}_\lambda^*, \pi_{\tilde{\mathfrak{g}}_\lambda}), \quad \xi \mapsto (\xi, 1),$$

is a Poisson embedding. So the question is how to “restrict” the known symplectic realization of $(\tilde{\mathfrak{g}}_\lambda^*, \pi_{\tilde{\mathfrak{g}}_\lambda})$ to obtain a symplectic realization of $(\mathfrak{g}^*, \pi_{\mathfrak{g},\lambda})$.

We will see later in Proposition 8.22 a general procedure for restricting symplectic realizations to submanifolds. Here we describe the outcome in this concrete situation.

Let $H \subset \tilde{G}_\lambda$ be the connected Lie subgroup integrating the Lie ideal

$$(6.23) \quad \mathbb{R} \hookrightarrow \tilde{\mathfrak{g}}_\lambda, \quad a \mapsto (0, a).$$

Assume that H is closed; one can show that this holds if \tilde{G}_λ is simply connected. We leave it as an exercise to check the following statements:

(a) The action of

$$H \times \tilde{G}_\lambda \rightarrow \tilde{G}_\lambda, \quad (h, g) \mapsto gh^{-1},$$

lifts to a Hamiltonian action of H on $T^*\tilde{G}_\lambda$ with moment map $\mu_H : T^*\tilde{G}_\lambda \rightarrow \mathbb{R}$ the composition of the moment map $\tilde{\mu}$ with the projection $\tilde{\mathfrak{g}}_\lambda^* \rightarrow \mathbb{R}$ dual to the inclusion (6.23).

(b) Since $H \subset \tilde{G}_\lambda$ is closed, the symplectic quotient

$$S := \mu_H^{-1}(1)/H$$

exists, and the restriction $\tilde{\mu} : \mu_H^{-1}(1) \rightarrow \mathfrak{g}^* \times 1 \simeq \mathfrak{g}^*$ is H -invariant, so it yields a map

$$\mu : S \rightarrow \mathfrak{g}^*.$$

(c) $\mu : (S, \omega_{\text{red}}) \rightarrow (\mathfrak{g}^*, \pi_{\mathfrak{g}, \lambda})$ is a surjective, Poisson submersion.

In other words, we have obtained the desired symplectic realization as a symplectic quotient:

$$\mu : (T^*\tilde{G}_\lambda //_1 H, \omega_{\text{red}}) \rightarrow (\mathfrak{g}^*, \pi_{\mathfrak{g}, \lambda}).$$

Exercise 6.26. Using the method just described, construct symplectic realizations for the following affine Poisson structures:

(a) $\pi = (1 + x) \frac{\partial}{\partial x} \wedge \frac{\partial}{\partial y}$ on \mathbb{R}^2 .

(b) $\pi = z \frac{\partial}{\partial x} \wedge \frac{\partial}{\partial y} + x \frac{\partial}{\partial y} \wedge \frac{\partial}{\partial z} + \frac{\partial}{\partial z} \wedge \frac{\partial}{\partial x}$ on \mathbb{R}^3 .



6.4. Libermann's Theorem and dual pairs

In our effort to understand symplectic realizations, we change the point of view slightly. Instead of searching for the symplectic manifold (S, ω) and a map μ into a given Poisson manifold (M, π) , we consider the following question:

- Given a surjective submersion $\mu : (S, \omega) \rightarrow M$ defined on a symplectic manifold, does there exist a Poisson structure π on M so that μ becomes a symplectic realization?

The answer to this question depends on the distribution that is symplectic orthogonal to the fibers of μ .

Theorem 6.27 (Libermann). *Consider a surjective submersion with connected fibers defined on a symplectic manifold:*

$$\mu : (S, \omega) \rightarrow M.$$

Then M admits a Poisson structure π such that $\mu : (S, \omega) \rightarrow (M, \pi)$ is a symplectic realization if and only if the ω -orthogonal to the fibers of μ

$$(\text{Ker } d\mu)^{\perp\omega} \subset TS$$

is an involutive distribution. Moreover, in this case π is unique.

Proof. Formula (6.1) shows that π is unique if it exists. Alternatively, note that μ induces an inclusion

$$\mu^* : C^\infty(M) \hookrightarrow C^\infty(S),$$

and this being a Poisson map uniquely determines π , provided it exists. This also shows that the existence of π is equivalent to

$$C_{\text{bas}}^\infty(S) := \mu^* C^\infty(M)$$

being closed under the Poisson bracket corresponding to ω :

$$(6.24) \quad f, g \in C_{\text{bas}}^\infty(S) \implies \{f, g\} \in C_{\text{bas}}^\infty(S).$$

Since μ has connected fibers, the image of μ^* can be described as

$$C_{\text{bas}}^\infty(S) = \{f \in C^\infty(S) : df(V) = 0 \quad \forall V \in \Gamma(\text{Ker } d\mu)\}.$$

Using that $df(V) = \omega(X_f, V)$, we obtain the following characterization:

$$f \in C_{\text{bas}}^\infty(S) \iff X_f \in \Gamma(\text{Ker } d\mu^{\perp\omega}).$$

Hence, the existence of π , i.e., condition (6.24), is equivalent to

$$(6.25) \quad X_f, X_g \in \Gamma(\text{Ker } d\mu^{\perp\omega}) \implies X_{\{f, g\}} = [X_f, X_g] \in \Gamma(\text{Ker } d\mu^{\perp\omega}).$$

Clearly, involutivity of $\text{Ker } d\mu^{\perp\omega}$ implies this condition. Conversely, we show that (6.25) implies that $[X, Y] \in \Gamma(\text{Ker } d\mu^{\perp\omega})$ for all $X, Y \in \Gamma(\text{Ker } d\mu^{\perp\omega})$. For this, we note that, as for any distribution, the map

$$\begin{aligned} \Gamma(\text{Ker } d\mu^{\perp\omega}) \times \Gamma(\text{Ker } d\mu^{\perp\omega}) &\rightarrow \Gamma(TS/\text{Ker } d\mu^{\perp\omega}), \\ (X, Y) &\mapsto [X, Y] \text{ mod } \text{Ker } d\mu^{\perp\omega} \end{aligned}$$

is $C^\infty(S)$ -bilinear, and hence it defines a tensor

$$\text{Ker } d\mu^{\perp\omega} \times \text{Ker } d\mu^{\perp\omega} \rightarrow TS/\text{Ker } d\mu^{\perp\omega}.$$

The involutivity of $\text{Ker } d\mu^{\perp\omega}$ is then equivalent to the vanishing of this tensor. Therefore, it suffices to show that, for any $p \in S$ and any $v \in$

$\text{Ker } d_p\mu^{\perp\omega}$, there exists a smooth function $f \in C_{\text{bas}}^\infty(S)$ such that $v = X_f|_p$. Note that we have isomorphisms

$$(\text{Ker } d_p\mu)^{\perp\omega} \xrightarrow{\omega^b} (\text{Ker } d_p\mu)^\circ \xleftarrow{\mu^*} T_{\mu(p)}^*M .$$

Under these isomorphisms, a vector $v \in (\text{Ker } d_p\mu)^{\perp\omega}$ corresponds to a covector $d_{\mu(p)}g \in T_{\mu(p)}^*M$, for some $g \in C^\infty(M)$. The function $f = \mu^*(g) \in C_{\text{bas}}^\infty(S)$ has the desired properties. \square

Exercise 6.28. In Libermann's Theorem, if one drops the assumption that the fibers of μ are connected, show that the direct implication still holds; i.e., if μ is a symplectic realization, then $(\text{Ker } d\mu)^{\perp\omega}$ is involutive. Construct a counterexample for the converse of this statement.

Remark 6.29. Given a symplectic realization $\mu : (S, \omega) \rightarrow (M, \pi)$, the proof of Libermann's Theorem shows that

$$d_p\mu((\text{Ker } d_p\mu)^{\perp\omega}) = \text{Im } \pi_{\mu(p)}^\sharp .$$

This means that the distribution generating the symplectic orthogonal foliation on S is mapped to the one generating the symplectic foliations. We will see in Chapter 12 that, for any leaf L of the symplectic orthogonal foliation, μ restricts to a submersion onto an open subset U of a symplectic leaf: $\mu : L \rightarrow U$. In particular, μ sends leaves into leaves — see Proposition 12.6.

In Libermann's Theorem there are two foliations: one corresponding to $\text{Ker } d\mu$ and one corresponding to the symplectic orthogonal $(\text{Ker } d\mu)^{\perp\omega}$. Since

$$((\text{Ker } d\mu)^{\perp\omega})^{\perp\omega} = \text{Ker } d\mu,$$

one may wonder how symmetric the roles of these foliations are. The first foliation is given as the fibers of the submersion μ — such a foliation is called **simple**. In the case when the second foliation is also simple — which always holds locally — so that

$$(\text{Ker } d\mu)^{\perp\omega} = \text{Ker } d\mu',$$

where $\mu' : S \rightarrow M'$ is a submersion with connected fibers, Libermann's Theorem shows that M' also has an induced Poisson structure π' .

Definition 6.30. A **dual pair** is a pair of symplectic realizations with symplectic orthogonal fibers:

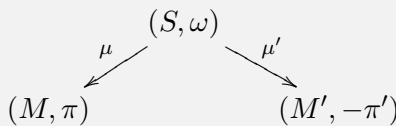

The choice of the minus sign in the diagram in this definition is in part justified by the proposition below.

Exercise 6.31. Show that one has a dual pair

$$\begin{array}{ccc} & (\mathbb{R}^4, \omega) & \\ \mu \swarrow & & \searrow \mu' \\ (\mathbb{R}^2, \pi) & & (\mathbb{R}^2, -\pi) \end{array}$$

where (see Example 6.12)

- ω is the symplectic form (6.4),
- π is the Poisson structure $\{x, y\} = xy$,
- $\mu(x, y, u, v) = (x, y)$ and $\mu'(x, y, u, v) = (xe^{yv}, ye^{-xu})$.

NOTE: μ' is the composition of μ with the Poisson anti-involution from Exercise 6.13 (c). This will be clarified later when we study symplectic groupoids.

The relationship between (M, π) and (M', π') in a dual pair is rather subtle, but very interesting. The following proposition illustrates that the transverse geometries to the symplectic foliation of two such Poisson structures are very closely related.

Proposition 6.32. Let $(M, \pi) \xleftarrow{\mu} (S, \omega) \xrightarrow{\mu'} (M', -\pi')$ be a dual pair.

- (i) For any $p \in S$, the isotropy Lie algebras $\text{Ker } \pi_{\mu(p)}$ and $\text{Ker } \pi'_{\mu'(p)}$ are isomorphic.
- (ii) For any $p \in S$, the transverse Poisson structures of (M, π) at $\mu(p)$ and of (M', π') at $\mu'(p)$ are isomorphic.
- (iii) If the fibers of both μ and μ' are connected, then there is a homeomorphism between the leaf spaces $M/\mathcal{F}_\pi \simeq M'/\mathcal{F}_{\pi'}$.

Proof. Item (i) follows from item (ii).

To prove item (ii), fix some $p_0 \in S$. To compare the transverse Poisson structures of the two Poisson manifolds at $\mu(p_0)$ and $\mu'(p_0)$, we choose a submanifold $Y \subset S$ such that

- $T_{p_0}Y$ is complementary to $\text{Ker } d_{p_0}\mu + \text{Ker } d_{p_0}\mu'$,
- Y is isotropic; i.e., $\omega|_Y = 0$.

For this, we choose first an isotropic complement $V \subset T_{p_0}S$ to the coisotropic space $\text{Ker } d_{p_0}\mu + \text{Ker } d_{p_0}\mu'$, and a Darboux chart around p_0 , identifying a neighborhood of p_0 in (S, ω) with a neighborhood of 0 in $(T_{p_0}S, \omega|_{T_{p_0}S})$. Let Y be the submanifold corresponding to V .

After shrinking Y we may assume that

$$(6.26) \quad T_p Y + \text{Ker } d_p \mu + \text{Ker } d_p \mu' = T_p S, \quad \forall p \in Y,$$

and that the two submersions restrict to diffeomorphisms

$$X \xleftarrow[\sim]{\mu} Y \xrightarrow[\sim]{\mu'} X'$$

with X and X' small enough slices in our Poisson manifolds. The two transverse Poisson structures π_X and $-\pi_{X'}$ are then lifted up, via these diffeomorphisms, to two Poisson structures π_Y and $-\pi'_Y$ on Y . We claim that $\pi'_Y = \pi_Y$.

The claim follows by a linear algebra computation based on Corollary 5.11. For this we prove the following description of π_Y at any $p \in Y$:

$$\pi_Y^\sharp(\beta) = w - v \quad (\beta \in T_p^* Y)$$

where $v \in \text{Ker } d_p \mu$, $w \in \text{Ker } d_p \mu'$ are unique elements such that

$$w - v \in T_p Y \quad \text{and} \quad (i_w \omega)|_{T_p Y} = \beta.$$

To see existence of such v and w we proceed as follows. Take $\alpha \in T_{\mu(p)}^* X$ such that $(\mu|_Y)^*(\alpha) = \beta$, and let $\tilde{\alpha} \in T_{\mu(p)}^* M$ be the extension of α vanishing on $(T_{\mu(p)} X)^\perp$. Let w be such that $i_w \omega = \mu^* \tilde{\alpha}$. Then $w \in (\text{Ker } d_p \mu)^\perp = \text{Ker } d_p \mu'$. Now, $v := w - \pi_Y^\sharp(\beta) \in \text{Ker } d_p \mu$ because

$$d_p \mu(\pi_Y^\sharp(\beta)) = \pi_X^\sharp(\alpha) = \pi^\sharp(\tilde{\alpha}) = d_p \mu(w),$$

where in the last equation we used that μ is a Poisson map.

If v' and w' are a second such pair, then the difference

$$v - v' = w - w' \in \text{Ker } d_p \mu \cap \text{Ker } d_p \mu' \cap (T_p Y)^\perp,$$

where we also used that

$$i_{w-w'} \omega|_{T_p Y} = (\beta - \beta)|_{T_p Y} = 0.$$

Taking symplectic orthogonals and using (6.26), we see that the intersection of the three spaces is trivial. So $v = v'$ and $w = w'$.

We have a similar description for the second leg:

$$(-\pi'_Y)^\sharp(\beta) = v' - w' \quad (\beta \in T_p^* Y)$$

where $v' \in \text{Ker } d_p \mu$, $w' \in \text{Ker } d_p \mu'$ satisfy $v' - w' \in T_p Y$ and $(i_{v'} \omega)|_{T_p Y} = \beta$.

Writing

$$w' = v' + (\pi'_Y)^\sharp(\beta)$$

and using that Y is isotropic, we readily obtain

$$(i_{w'}\omega)|_{T_p Y} = (i_{v'}\omega)|_{T_p Y} + (i_{(\pi'_Y)^\sharp(\beta)}\omega)|_{T_p Y} = \beta.$$

The description of $\pi_Y^\sharp(\beta)$ above implies that $v = v'$ and $w = w'$, and so

$$\pi_Y^\sharp(\beta) = w - v = w' - v' = (\pi'_Y)^\sharp(\beta),$$

proving the desired statement.

The correspondence in part (iii) is given by

$$M/\mathcal{F}_\pi \simeq M'/\mathcal{F}_{\pi'}, \quad L \leftrightarrow L' \iff \mu^{-1}(L) = (\mu')^{-1}(L').$$

That this is well-defined follows from Remark 6.29. We leave it to the reader to check that this is a homeomorphism. \square

Remark 6.33. In the proof of item (ii), we have chosen Y to be an isotropic submanifold. If this is not satisfied, then a similar argument shows that the Poisson structures on Y are related by a gauge transformation $\pi_Y = e^B \pi'_Y$, where $B = \omega|_Y$.

Example 6.34. Let $\mu : (S, \omega) \rightarrow \mathfrak{g}^*$ be a G -Hamiltonian space. Recall from Lemma 1.34 that the orbits of the action and the fibers of μ are symplectic orthogonal. Hence, if the action is proper and free — so μ is a submersion — we obtain a dual pair

$$\begin{array}{ccc} & (S, \omega) & \\ \mu \swarrow & & \searrow p \\ (\mu(S), \pi_{\mathfrak{g}}) & & (S/G, \pi_{S/G}) \end{array}$$

We have already encounter versions of properties (i) and (iii) in Proposition 1.33 and Problem 4.10.

For a specific example we apply the previous discussion to Example 1.32 obtaining

$$\begin{array}{ccc} & (\mathbb{C}^2 \setminus \{0\}, \omega) & \\ \mu \swarrow & & \searrow p \\ (\mathbb{R}, 0) & & ((\mathbb{C}^2 \setminus \{0\})/\mathbb{S}^1, \pi) \end{array}$$

where the moment map $\mu : \mathbb{C}^2 \setminus \{0\} \rightarrow \mathbb{R}$ is the \mathbb{S}^1 -invariant function

$$\mu(z, w) = -\frac{i}{2}(z\bar{w} - \bar{z}w).$$

Writing $z = x + iy$ and $w = u + iv$ this function is the determinant

$$\mu(x, y, u, v) = \begin{vmatrix} x & y \\ u & v \end{vmatrix};$$

hence the fibers of μ are connected. Since \mathbb{S}^1 is connected, we conclude that the quotient Poisson structure π on $(\mathbb{C}^2 \setminus \{0\})/\mathbb{S}^1$ has leaf space homeomorphic to \mathbb{R} .

The \mathbb{S}^1 -invariant functions on $\mathbb{C}^2 \setminus \{0\}$ defined in Example 1.32

$$\sigma_1 = \frac{1}{2} (|z|^2 + |w|^2), \quad \sigma_2 = \frac{1}{2} (|z|^2 - |w|^2), \quad \sigma_3 = z\bar{w} + \bar{z}w$$

are related to the moment map by the algebraic relation

$$4\mu^2 = \sigma_1^2 - \sigma_2^2 - \sigma_3^2.$$

As we saw, they also define a Poisson map

$$\sigma : (\mathbb{C}^2 \setminus \{0\})/\mathbb{S}^1 \rightarrow \mathbb{R}^3 \simeq \mathfrak{sl}(2, \mathbb{R})^*.$$

One then obtains an open set $U \subset (\mathbb{C}^2 \setminus \{0\})/\mathbb{S}^1$ on which σ restricts to a Poisson embedding

$$\sigma : U \rightarrow \mathfrak{sl}(2, \mathbb{R})^*.$$

The existence of this isomorphism is not accidental and can be further explained using dual pairs as follows.

Let G and H be two Lie groups with commuting, proper, and free Hamiltonian actions on (S, ω) , such that the orbits are symplectic orthogonal. For simplicity we assume that G , H , and the fibers of the moment maps are connected. Then we obtain a dual pair

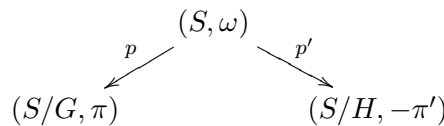

It follows from the assumptions that the two legs should also describe the moment maps of the actions; i.e., we obtain a commutative diagram

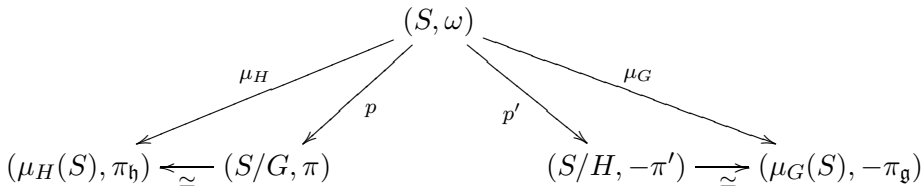

Therefore, in this situation the quotient Poisson structures become linear.

Returning to the example above of the \mathbb{S}^1 -action on $\mathbb{C}^2 \setminus \{0\}$, there is indeed a Hamiltonian action of the group $SL(2, \mathbb{R})$, commuting with the

\mathbb{S}^1 -action. Namely, the standard action coming from the inclusion $SL(2, \mathbb{R}) \subset GL(2, \mathbb{C})$ has as moment map precisely $\mu' = (\sigma_1, \sigma_2, \sigma_3) : \mathbb{C}^2 \setminus \{0\} \rightarrow \mathfrak{sl}(2, \mathbb{R})^* \simeq \mathbb{R}^3$. The action is free and proper on $S = \{\mu > 0\} \subset \mathbb{C}^2 \setminus \{0\}$ and the entire discussion can be represented by the following diagram:

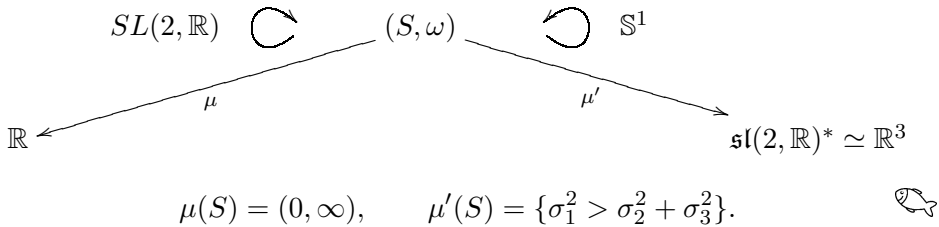

6.5. Local existence

In this section we discuss Weinstein’s original construction [147] of local symplectic realizations. In Chapter 12 we will also give a global version of this construction, which will provide further insight into the local formulas obtained in this section.

Let π be a Poisson structure on \mathbb{R}^n with coordinates $x = (x^1, \dots, x^n)$. In order to build a symplectic realization we add new coordinates $p = (p_1, \dots, p_n)$ which we interpret as dual coordinates on $N := (\mathbb{R}^n)^*$. As for linear Poisson structures — see Section 6.3 — we look for a symplectic form of the type $\omega = -d\Theta$ where Θ is a 1-form on $\mathbb{R}^{2n} = \mathbb{R}^n \times N$ which does not contain dx^i ’s

$$\Theta = \sum_{i=1}^n f^i(x, p) dp_i \in \Gamma(\mathbb{R}^n \times N, \text{pr}_N^* T^* N)$$

and which makes the projection $\mu : \mathbb{R}^n \times N \rightarrow \mathbb{R}^n$ a Poisson map. In order to find such a 1-form, we again use as inspiration the linear case and rewrite this last condition as the Maurer-Cartan equation for the infinite-dimensional Lie algebra

$$\mathfrak{g} := C^\infty(\mathbb{R}^n).$$

Then we can view $\Theta \in \Omega^1(N, \mathfrak{g})$, and the Maurer-Cartan equation for Θ

$$d^N \Theta + \frac{1}{2} \{\Theta, \Theta\} = 0$$

is equivalent to the system of partial differential equations

$$(6.27) \quad \{f^i, f^j\}(x, p) = \frac{\partial f^i}{\partial p_j}(x, p) - \frac{\partial f^j}{\partial p_i}(x, p) \quad (1 \leq i, j \leq n).$$

Here we use the notation d^N to stress that we use the exterior derivative for forms on N . This is needed since Θ denotes both for the 1-form on N and the 1-form on $\mathbb{R}^n \times N$.

Exercise 6.35. With the notation from before, prove the following:

- (a) The 2-form $\omega = -d\Theta$ is nondegenerate precisely on the open set U where the partial Jacobian matrix $(\frac{\partial f^i}{\partial x^j})_{i,j}$ is invertible.
- (b) The projection $\mu : (\mathbb{R}^n \times N, -d\Theta) \rightarrow (\mathbb{R}^n, \pi)$ restricts to a Poisson map on U if and only if Θ satisfies the Maurer-Cartan equation (6.27) on U .

The main problem now is that $\mathfrak{g} = C^\infty(\mathbb{R}^n)$ is an infinite-dimensional Lie algebra and there is no obvious Lie group integrating it. However, as we mentioned at the end of Section 6.3, in the finite-dimensional case the pullback of the Maurer-Cartan form via the exponential can be described completely in terms of the Lie algebra (6.20). In order to obtain a differential form on N , we embed $N = (\mathbb{R}^n)^* \hookrightarrow \mathfrak{g} = C^\infty(\mathbb{R}^n)$ in the obvious way:

$$p \mapsto f_p := \langle \cdot, p \rangle \in C^\infty(\mathbb{R}^n),$$

where $\langle \cdot, \cdot \rangle : \mathbb{R}^n \times (\mathbb{R}^n)^* \rightarrow \mathbb{R}$ is the canonical pairing. Hence,

$$(6.28) \quad \text{ad}_{f_p} = \mathcal{L}_{X_{f_p}} : C^\infty(\mathbb{R}^n) \rightarrow C^\infty(\mathbb{R}^n), \quad \text{with} \quad X_{f_p} = \sum_{i,j} p_i \pi^{ij} \frac{\partial}{\partial x^j}.$$

Interpreting $e^{-t \text{ad}_{f_p}}$ as the adjoint action — see Example A.5 for the explanation of the sign — formula (6.20) suggests that the 1-form we are looking for is $\Theta \in \Omega^1(N, \mathfrak{g}) \subset \Omega^1(\mathbb{R}^n \times N)$ given by

$$(6.29) \quad \begin{aligned} \Theta_{(x,p)}(u, \xi) &= \int_0^1 \langle x, e^{-t \text{ad}_{f_p}} \xi \rangle dt \\ &= \int_0^1 \langle e^{t \text{ad}_{f_p}^*} x, \xi \rangle dt = \int_0^1 \langle \phi_{X_{f_p}}^{-t}(x), \xi \rangle dt, \end{aligned}$$

where $\phi_{X_{f_p}}^t = e^{-t \text{ad}_{f_p}^*}$ is the flow of X_{f_p} .

If we differentiate this last expression for Θ , as we did for the linear case in Exercise 6.23, we obtain an explicit candidate for a symplectic realization. In order to simplify the result further, we pullback $-d\Theta$ along $(x, p) \mapsto (x, -p)$, and we obtain the formula in the following result:

Theorem 6.36 (Existence of local symplectic realizations). *The 2-form*

$$\omega = \int_0^1 (\phi^t)^* \omega_{\text{can}} dt \in \Omega^2(\mathbb{R}^{2n}), \quad \text{with} \quad \phi^t(x, p) = (\phi_{X_{f_p}}^t(x), p),$$

is symplectic on an open set containing $\mathbb{R}^n \times \{0\}$ and together with the restriction of the projection

$$\mu : (\mathbb{R}^{2n}, \omega) \rightarrow (\mathbb{R}^n, \pi), \quad (x, p) \mapsto x,$$

yields a symplectic realization of (\mathbb{R}^n, π) .

Proof. First of all, note that since ϕ^t fixes the points $(x, 0)$ we can start by choosing a small enough neighborhood of $\mathbb{R}^n \times \{0\}$ where the isotopy ϕ^t is defined up to time 1, so the formula for ω makes sense. We will work inside this neighborhood.

The formula for ω can be written more explicitly:

$$\begin{aligned} \omega_{(x,p)}((u, \xi), (v, \eta)) &= \int_0^1 \omega_{\text{can}}((d\phi^t)_{(x,p)}(u, \xi), (d\phi^t)_{(x,p)}(v, \eta)) dt \\ &= \int_0^1 (\langle (d\psi^t)_{(x,p)}(u, \xi), \eta \rangle - \langle (d\psi^t)_{(x,p)}(v, \eta), \xi \rangle) dt, \end{aligned}$$

where $\psi^t : \mathbb{R}^{2n} \rightarrow \mathbb{R}^n$, $\psi^t(x, p) = \phi^t_{X_{f_p}}(x)$ is the second component of ϕ^t .

Let us first look at the points with $p = 0$. We claim that

$$(6.30) \quad (d\psi^t)_{(x,0)} : \mathbb{R}^{2n} \rightarrow \mathbb{R}^n, \quad (u, \xi) \mapsto u + t\pi_x^\sharp(\xi).$$

The fact that $(u, 0)$ is sent to u is clear since $\phi^t(x, 0) = x$. For the image of $(0, \xi)$ we look at the partial derivatives of ψ^t with respect to the coordinates p_i at $(x, 0)$. Using formula (6.28) for X_{f_p} we find

$$\begin{aligned} \left. \frac{d}{dt} \frac{\partial}{\partial p_i} \right|_{p=0} \psi^t(x, p) &= \left. \frac{\partial}{\partial p_i} \right|_{p=0} \frac{d}{dt} \psi^t(x, p) = \left. \frac{\partial}{\partial p_i} \right|_{p=0} X_{f_p}(\psi^t(x, p)) \\ &= \sum_j \pi^{ij}(x) \frac{\partial}{\partial x^j}. \end{aligned}$$

Since this is independent of t we conclude that

$$\left. \frac{\partial}{\partial p_i} \right|_{p=0} \psi^t(x, p) = t\pi_x^\sharp(dx^i),$$

so (6.30) holds. It follows that

$$\omega_{(x,0)}((u, \xi), (v, \eta)) = \langle u, \eta \rangle - \langle v, \xi \rangle + \pi_x(\xi, \eta),$$

showing that $\omega_{(x,0)}$ is nondegenerate for all x .

Using this, one checks right away that at points $(x, 0)$ the differential of the second projection $\mu : \mathbb{R}^{2n} \rightarrow \mathbb{R}^n$ fits into a commutative diagram

$$\begin{array}{ccc} T_{(0,x)}^* \mathbb{R}^{2n} & \xrightarrow{(\omega_{(x,0)}^\flat)^{-1}} & T_{(0,x)} \mathbb{R}^{2n} \\ (d\mu)^* \uparrow & & \downarrow d\mu \\ T_x^* \mathbb{R}^n & \xrightarrow{\pi_x^\sharp} & T_x \mathbb{R}^n \end{array}$$

All that remains is to check the involutivity condition in Libermann's Theorem on a neighborhood of $\mathbb{R}^n \times \{0\}$ for the projection $\mu : (\mathbb{R}^{2n}, \omega) \rightarrow \mathbb{R}^n$. This is because the previous diagram forces the Poisson structure induced

on the base to coincide with π . Involutivity will follow from the equality of bundles

$$(6.31) \quad (\text{Ker } d\mu)^{\perp\omega} = \text{Ker } d\psi^1,$$

which we will prove to hold in a neighborhood of $\mathbb{R}^n \times \{0\}$. For (6.31) to hold at a point (x, p) where ω is nondegenerate, it suffices to show that

$$(6.32) \quad \omega_{(x,p)}((0, \xi_0), (u_0, \eta_0)) = 0, \quad \text{whenever } (d\psi^1)_{(x,p)}(u_0, \eta_0) = 0.$$

Let $\gamma(t) = \psi^t(x, p)$ be the integral curve of X_{f_p} starting at x and consider the path of endomorphisms of $T\mathbb{R}^n$ covering γ :

$$L_t : T_{\gamma(t)}\mathbb{R}^n \rightarrow T_{\gamma(t)}\mathbb{R}^n,$$

$$\frac{\partial}{\partial x_k} \mapsto \left[\frac{\partial}{\partial x_k}, X_{f_p} \right]_{\gamma(t)} = \sum_{i,j} p_i \frac{\partial \pi^{ij}}{\partial x^k}(\gamma(t)) \frac{\partial}{\partial x^j}.$$

Using the local version of the Poisson condition (1.4), one can show that L_t satisfies the equation

$$(6.33) \quad \frac{d}{dt} \pi_{\gamma(t)}^{\sharp}(\xi) = L_t \circ \pi_{\gamma(t)}^{\sharp}(\xi) + \pi_{\gamma(t)}^{\sharp} \circ L_t^*(\xi), \quad \forall \xi \in (\mathbb{R}^n)^*.$$

Then (6.32) follows immediately from the following lemma:

Lemma 6.37. *We have*

$$\omega_{(x,p)}((0, \xi_0), (u_0, \eta_0)) = \langle u_1, \tilde{\xi}_1 \rangle,$$

where

(i) u_1 is the end point of the path

$$t \mapsto u_t := (d\psi^t)_{(x,p)}(u_0, \eta_0) \in T_{\gamma(t)}\mathbb{R}^n,$$

(ii) $\tilde{\xi}_1$ is the end point of the solution $t \mapsto \tilde{\xi}_t \in T_{\gamma(t)}^*\mathbb{R}^n$ of the initial value problem

$$(6.34) \quad \frac{d}{dt} \tilde{\xi}_t = -L_t^* \tilde{\xi}_t + \xi_0, \quad \tilde{\xi}_0 = 0.$$

In order to prove this lemma, we start by observing the following:

- (a) The path $t \mapsto u_t$ satisfies the ODE $\frac{d}{dt} u_t = L_t u_t + \pi_{\gamma(t)}^{\sharp}(\eta_0)$.
- (b) $\pi_{\gamma(t)}^{\sharp}$ maps the path $t \mapsto \tilde{\xi}_t$ to the path $t \mapsto v_t := (d\psi^t)_{(x,p)}(0, \xi_0)$.

Item (a) follows from an easy direct computation, similar to the proof of (6.30). For (b), first apply (a) to the path $t \mapsto v_t$, obtaining

$$\frac{d}{dt}v_t = L_tv_t + \pi_{\gamma(t)}^\sharp(\xi_0).$$

Since $v_0 = 0 = \pi_{\gamma(0)}^\sharp(\tilde{\xi}_0)$, to prove (b) it suffices to check that this ODE is also satisfied by $t \mapsto \pi_{\gamma(t)}^\sharp(\tilde{\xi}_t)$. We leave it to the reader to check that this is a consequence of the defining equation (6.34) for $t \mapsto \tilde{\xi}_t$ and (6.33).

We can now prove the lemma. Note that the definition of ω gives

$$\omega_{(x,p)}((0, \xi_0), (u_0, \eta_0)) = \int_0^1 (\langle v_t, \eta_0 \rangle - \langle u_t, \xi_0 \rangle) dt.$$

On the other hand, using the ODEs that u_t and $\tilde{\xi}_t$ satisfy, we find

$$\begin{aligned} \frac{d}{dt}\langle u_t, \tilde{\xi}_t \rangle &= \langle L_t u_t + \pi_{\gamma(t)}^\sharp(\eta_0), \tilde{\xi}_t \rangle + \langle u_t, -L_t^* \tilde{\xi}_t + \xi_0 \rangle \\ &= \langle \pi_{\gamma(t)}^\sharp(\eta_0), \tilde{\xi}_t \rangle + \langle u_t, \xi_0 \rangle \\ &= -\langle \pi_{\gamma(t)}^\sharp(\tilde{\xi}_t), \eta_0 \rangle + \langle u_t, \xi_0 \rangle \\ &= \langle v_t, \eta_0 \rangle - \langle u_t, \xi_0 \rangle, \end{aligned}$$

where we used the antisymmetry of π and item (b) above. Therefore

$$\omega_{(x,p)}((0, \xi_0), (u_0, \eta_0)) = \int_0^1 \frac{d}{dt}\langle u_t, \tilde{\xi}_t \rangle dt = \langle u_1, \tilde{\xi}_1 \rangle.$$

This shows that the lemma holds, and it completes the proof of the local existence of symplectic realizations. \square

For a general Poisson manifold (M, π) , the theorem gives a symplectic realization of dimension $2 \dim M$ of any domain of a chart for M . However, these depend on choices of local coordinates, and it is nontrivial to show that these local constructions can be glued to obtain a global symplectic realization of (M, π) — see [37]. We will discuss later in Chapter 11 an appropriate notion of connection in Poisson geometry which will allow us to give a global version of Theorem 6.36, proving the existence of symplectic realizations for any Poisson manifold. In Chapter 12, our quest to understand the existence of proper — more generally, *complete* — symplectic realizations will lead us to discover some nonobvious, important, global properties of Poisson manifolds.

Problems

6.1. Let (V, π_V) be a constant Poisson structure of corank s . Show that if $X_1, \dots, X_s \in V$ are linearly independent vectors transverse to $\pi_V^\sharp(V^*)$, then the first projection

$$\mu : V \oplus \mathbb{R}^s \rightarrow V$$

is a symplectic realization of (V, π_V) , where $V \oplus \mathbb{R}^s$ is equipped with the constant bivector

$$\pi_{V \oplus \mathbb{R}^s} := \pi_V + \sum_{i=1}^s X_i \wedge \frac{\partial}{\partial x^i}.$$

6.2. Consider \mathbb{R}^4 equipped with the canonical symplectic structure ω_{can} . Find an explicit map $\mu : \mathbb{R}^4 \rightarrow \mathbb{R}^2$ which gives a symplectic realization of the linear Poisson structure defined by

$$\{x, y\} = x.$$

6.3. Let $\mu : (S, \omega) \rightarrow (M, \pi)$ be a symplectic realization. Show that if the fibers of μ are isotropic, then the rank of π must be constant.

6.4. Let (S, ω) be a symplectic manifold, and let $\mu : S \rightarrow M$ be a surjective submersion. Show that μ is a symplectic realization of the zero Poisson structure on M if and only if the fibers of μ are coisotropic submanifolds of (S, ω) . Conclude that fibration over M with Lagrangian fibers is the same as a symplectic realization of the zero Poisson structure on M of smallest possible dimension.

6.5. Let (M, π) be the Poisson structure associated to the cosymplectic structure (θ, ω) . Consider

$$\Omega := \text{pr}_M^*(\omega) + d\varphi \wedge \text{pr}_M^*(\theta) \in \Omega^2(M \times \mathbb{S}^1).$$

Show that

$$\text{pr}_M : (M \times \mathbb{S}^1, \Omega) \rightarrow (M, \pi)$$

is a symplectic realization.

6.6. Formulate and prove a version of the previous exercise for regular Poisson manifolds of codimension larger than 1.

6.7. Find a map $\mu' : \mathbb{R}^4 \rightarrow \mathbb{R}^2$ giving a dual pair

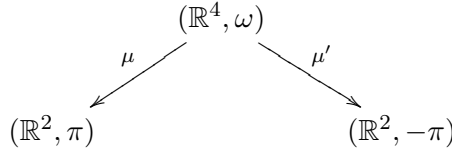

where the left leg is the symplectic realization (6.7).

6.8. Let G be a Lie group with Lie algebra \mathfrak{g} . Show that the symplectic realization (6.14) of $(\mathfrak{g}^*, \pi_{\mathfrak{g}})$ fits into the dual pair

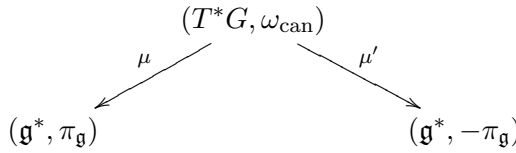

where $\mu'(\alpha) := R_g^* \alpha$, for $\alpha \in T_g^*G$.

6.9. Let (S, ω) be a symplectic manifold, let (M, π) and (M', π') be two Poisson manifolds, and let $\mu : S \rightarrow M$ and $\mu' : S \rightarrow M'$ be two surjective submersions. Show that the following are equivalent:

- (a) $(M, \pi) \xleftarrow{\mu} (S, \omega) \xrightarrow{\mu'} (M', -\pi')$ is a dual pair.
- (b) $(\mu, \mu') : (S, \omega) \rightarrow (M, \pi) \times (M', -\pi')$ is a Poisson map and $\dim M + \dim M' = \dim S$.

6.10. Calculate the symplectic realization of an arbitrary constant Poisson structure on \mathbb{R}^n which results from Theorem 6.36.

6.11. Deduce Theorem 5.19 using Proposition 6.32 and Theorem 6.36.

6.12. Let G be a Lie group with a free and proper action on a symplectic manifold (S, ω) of dimension $\dim S = 2 \dim G$. Let π be the Poisson structure on $M := S/G$ for which the projection $p : S \rightarrow M$ is a symplectic realization.

- (a) Let $y \in M$ be a zero of π . Show that $L := p^{-1}(y)$ is a Lagrangian submanifold of M .
- (b) Show that there is linear isomorphism map $\phi : T_y^*M \xrightarrow{\sim} \mathfrak{g}$ that satisfies

$$(d_x p)^*(\xi) = i_{a_x(\phi(\xi))} \omega, \quad \forall x \in L,$$

where $a : \mathfrak{g} \rightarrow \mathfrak{X}(S)$ denotes the infinitesimal action (in particular, show that the above is independent of x).

- (c) Show that the map ϕ is a Lie algebra isomorphism, where T_y^*M is viewed as the isotropy Lie algebra at y .
(HINT: Use Exercise 2.17.)

-
- (d) Construct a connected Poisson manifold which at two zeros has nonisomorphic isotropy Lie algebras. Conclude that this Poisson manifold is not the quotient of a symplectic manifold of twice its dimension by a free and proper symplectic action.

Dirac Geometry

In Poisson geometry one sometimes has to deal with geometric structures that cross its boundaries. We have already seen some instances of this phenomenon.

For example, given a Hamiltonian G -space (M, ω, μ) , assuming that the G -action on $\mu^{-1}(0)$ is free and proper, the symplectic quotient $M // G = \mu^{-1}(0)/G$ has a reduced symplectic form ω_0 satisfying (Theorem B.19)

$$p_0^* \omega_0 = \omega|_{\mu^{-1}(0)}.$$

In this reduction procedure the submanifold $(\mu^{-1}(0), \omega|_{\mu^{-1}(0)})$ appears naturally, although it is not a symplectic submanifold. For a Hamiltonian G -space (M, π, μ) , where π is a Poisson structure, the situation is even more dramatic, since it is not even clear what kind of geometric structure one has on $\mu^{-1}(0)$ although the quotient $\mu^{-1}(0)/G$ still carries a Poisson structure. The issue is that passing to submanifolds in general takes us out of the Poisson category.

We have also noticed before that there are some issues with morphisms in the Poisson category. For example, we have observed that a symplectic immersion $(N, \omega_N) \hookrightarrow (M, \omega_M)$ is never a Poisson map if $\dim N < \dim M$, although both domain and target are Poisson manifolds. More generally, the inclusion of a Poisson transversal (N, π_N) in a Poisson manifold (M, π_M) is not a Poisson map.

All these issues can be overcome by enlarging the Poisson category to allow for manifolds with presymplectic foliations, i.e., foliations with leafwise closed 2-forms which may degenerate. Such structures are called *Dirac* and will be studied in this chapter.

7.1. Constant Dirac structures

We know already that it is much more efficient to define a Poisson manifold via bivector fields rather than as a (singular) foliation with a leafwise symplectic form. Similarly, defining a Dirac manifold as a (singular) foliation with a leafwise closed 2-form is very cumbersome and there is a much more efficient procedure to deal with them, as we will see now. The price to pay is a bit of abstraction.

The main underlying idea behind Dirac geometry is to replace the tangent bundle TM of a manifold by the so-called *generalized tangent bundle*

$$\mathbb{T}M := TM \oplus T^*M,$$

together with its relevant structure. In this section we discuss the linear algebra underlying this construction, which will be applied later to the tangent space of M at each point.

Fix a real vector space V of dimension m , and consider

$$\mathbb{V} := V \oplus V^* = \{v + \alpha : v \in V, \alpha \in V^*\}.$$

The vector space \mathbb{V} has a natural bilinear symmetric 2-form $(\cdot, \cdot)_{\mathbb{V}}$ given by

$$(7.1) \quad (v + \alpha, w + \beta)_{\mathbb{V}} := \alpha(w) + \beta(v).$$

The objects of interest will be the following subspaces of $(\mathbb{V}, (\cdot, \cdot)_{\mathbb{V}})$.

Definition 7.1. A **Dirac structure** on the m -dimensional vector space V is an m -dimensional subspace $\mathbb{L} \subset \mathbb{V}$ on which $(\cdot, \cdot)_{\mathbb{V}}$ vanishes:

$$(s_1, s_2)_{\mathbb{V}} = 0, \quad \forall s_1, s_2 \in \mathbb{L}.$$

We denote by $\mathfrak{D}(V)$ the collection of all such subspaces.

Example 7.2 (Subspaces). Any linear subspace $F \subset V$ together with its annihilator $F^\circ \subset V^*$ give rise to a Dirac structure

$$\mathbb{L}_F := F \oplus F^\circ \subset \mathbb{V}. \quad \img alt="fish icon" data-bbox="825 695 855 710"/>$$

Our main reason for introducing Dirac structures is that they provide a common framework for 2-forms and bivectors. The following two examples illustrate this.

Example 7.3 (2-forms). A 2-form $\omega \in \wedge^2 V^*$ can be interpreted as a skew-symmetric linear map $\omega^\flat : V \rightarrow V^*$. Then its graph

$$\mathbb{L}_\omega := \{v + i_v \omega : v \in V\} \subset \mathbb{V}$$

is a Dirac structure. This gives a way to view 2-forms as Dirac structures

$$\bigwedge^2 V^* \ni \omega \mapsto \mathbb{L}_\omega \in \mathfrak{D}(V).$$

Lemma 7.4. *A Dirac structure $\mathbb{L} \in \mathfrak{D}(V)$ is of type \mathbb{L}_ω for some $\omega \in \wedge^2 V^*$ (necessarily unique) if and only if \mathbb{L} is transverse to V^* .*

In fact, letting $\text{pr}_V : \mathbb{V} \rightarrow V$ denote the projection onto the first factor, for $\mathbb{L} \in \mathfrak{D}(V)$ one has

$$\begin{aligned} \mathbb{L} \text{ is transverse to } V^* &\iff \mathbb{V} = \mathbb{L} \oplus V^* \\ &\iff \mathbb{L} \cap V^* = \{0\} \\ &\iff \text{pr}_V(\mathbb{L}) = V \iff \text{pr}_V|_{\mathbb{L}} : \mathbb{L} \xrightarrow{\sim} V. \end{aligned}$$

Hence, composing the inverse of $\text{pr}_V|_{\mathbb{L}} : \mathbb{L} \xrightarrow{\sim} V$ with the projection in the second factor $\text{pr}_{V^*}|_{\mathbb{L}} : \mathbb{L} \xrightarrow{\sim} V^*$, we obtain a skew-symmetric linear map $\omega^\flat : V \rightarrow V^*$ and we have $\mathbb{L} = \mathbb{L}_\omega$. 

Example 7.5 (Bivectors). In analogy with the previous example, a bivector $\pi \in \wedge^2 V$ can be interpreted as a linear map $\pi^\sharp : V^* \rightarrow V$. Then its graph

$$\mathbb{L}_\pi := \{\pi^\sharp\alpha + \alpha : \alpha \in V^*\} \subset \mathbb{V}$$

is a Dirac structure. This gives a way to view bivectors as Dirac structures

$$\bigwedge^2 V \ni \pi \mapsto \mathbb{L}_\pi \in \mathfrak{D}(V).$$

Lemma 7.6. *A Dirac structure $\mathbb{L} \in \mathfrak{D}(V)$ is of type \mathbb{L}_π for some $\pi \in \wedge^2 V$ (necessarily unique) if and only if \mathbb{L} is transverse to V .*

Again, for dimensional reasons, if $\mathbb{L} \in \mathfrak{D}(V)$, one has

$$\begin{aligned} \mathbb{L} \text{ is transverse to } V &\iff \mathbb{V} = \mathbb{L} \oplus V \\ &\iff \mathbb{L} \cap V = \{0\} \\ &\iff \text{pr}_{V^*}(\mathbb{L}) = V^* \iff \text{pr}_{V^*}|_{\mathbb{L}} : \mathbb{L} \xrightarrow{\sim} V^*. \end{aligned}$$

It follows that the composition $\pi^\sharp := \text{pr}_V \circ (\text{pr}_{V^*}|_{\mathbb{L}})^{-1} : V^* \rightarrow V$ is a skew-symmetric linear map and that we have $\mathbb{L} = \mathbb{L}_\pi$. 

In general, to a Dirac structure $\mathbb{L} \in \mathfrak{D}(V)$ one can associate two interesting subspaces of V , namely:

- The **range** of \mathbb{L} , defined as $\text{pr}_V(\mathbb{L}) \subset V$. The range equals V if and only if \mathbb{L} is associated to a 2-form, as in Example 7.3.
- The **kernel** of \mathbb{L} , defined as $\mathbb{L} \cap V \subset V$. By Lemma 7.6, the kernel is trivial if and only if \mathbb{L} is associated to a bivector.

Exercise 7.7. Show that the range and the kernel of a Dirac structure $\mathbb{L} \in \mathfrak{D}(V)$ fit into the short exact sequences

$$\begin{aligned} 0 &\longrightarrow (\mathrm{pr}_V(\mathbb{L}))^\circ \longrightarrow \mathbb{L} \xrightarrow{\mathrm{pr}_V} \mathrm{pr}_V(\mathbb{L}) \longrightarrow 0 \\ 0 &\longrightarrow \mathbb{L} \cap V \longrightarrow \mathbb{L} \xrightarrow{\mathrm{pr}_{V^*}} (\mathbb{L} \cap V)^\circ \longrightarrow 0 \end{aligned}$$

As in the case of bivectors — see Proposition 2.24 — there is another important piece of a Dirac structure:

Proposition 7.8. For any Dirac structure $\mathbb{L} \in \mathfrak{D}(V)$ one has an induced 2-form on its range, $\Omega_{\mathbb{L}} \in \wedge^2 \mathrm{pr}_V(\mathbb{L})^*$, defined as follows:

$$(7.2) \quad \Omega_{\mathbb{L}}(v_1, v_2) := \alpha_1(v_2) = -\alpha_2(v_1),$$

where for $v_i \in \mathrm{pr}_V(\mathbb{L})$ one chooses $\alpha_i \in V^*$ so that $v_i + \alpha_i \in \mathbb{L}$.

Moreover, this gives a 1-to-1 correspondence

$$\left\{ \begin{array}{l} \text{Dirac structures} \\ \mathbb{L} \in \mathfrak{D}(V) \end{array} \right\} \xleftrightarrow{\sim} \left\{ \begin{array}{l} \text{pairs } (F, \Omega) \text{ consisting of} \\ - \text{ a subspace } F \subset V, \\ - \text{ a form } \Omega \in \wedge^2 F^* \end{array} \right\},$$

where \mathbb{L} can be recovered from the pair (F, Ω) by

$$\mathbb{L}(F, \Omega) := \{v + \alpha \in \mathbb{V} : v \in F, \alpha|_F = i_v \Omega\}.$$

Exercise 7.9. Prove Proposition 7.8.

Another important property of Dirac structures is that they can be pulled back as well as pushed forward under linear maps. More precisely, given a linear map $A : V_1 \rightarrow V_2$, the **pullback** operation on Dirac structures $A^! : \mathfrak{D}(V_2) \rightarrow \mathfrak{D}(V_1)$ is defined by

$$(7.3) \quad A^!(\mathbb{L}_2) := \{v_1 + A^*(\alpha_2) : A(v_1) + \alpha_2 \in \mathbb{L}_2\},$$

and the **pushforward** operation $A_! : \mathfrak{D}(V_1) \rightarrow \mathfrak{D}(V_2)$ is defined by

$$(7.4) \quad A_!(\mathbb{L}_1) := \{A(v_1) + \alpha_2 : v_1 + A^*(\alpha_2) \in \mathbb{L}_1\}.$$

Remark 7.10. We use the symbol $!$ to distinguish pullbacks/pushforwards of Dirac structure from ordinary pullbacks/pushforwards.

Exercise 7.11. Show that these operations take Dirac structures to Dirac structures.

Finally, one additional important property of Dirac structures concerns the presence of hidden symmetries, called *gauge transformations*: each $B \in \wedge^2 V^*$ induces an isometry of $(\mathbb{V}, (\cdot, \cdot)_{\mathbb{V}})$:

$$e^B := \exp \begin{pmatrix} 0 & 0 \\ B^\flat & 0 \end{pmatrix} = \begin{pmatrix} 1 & 0 \\ B^\flat & 1 \end{pmatrix} : \mathbb{V} \rightarrow \mathbb{V}, \quad v + \alpha \mapsto v + \alpha + i_v B.$$

In particular, for any Dirac structure $\mathbb{L} \in \mathfrak{D}(V)$, one obtains a new Dirac structure

$$e^B \mathbb{L} = \{v + \alpha + i_v B : v + \alpha \in \mathbb{L}\}.$$

Definition 7.12. The Dirac structure $e^B \mathbb{L} \in \mathfrak{D}(V)$ is called the **gauge transform** of \mathbb{L} with respect to the 2-form $B \in \wedge^2 V^*$.

Under the correspondence given by Proposition 7.8, if $\mathbb{L} = \mathbb{L}(F, \Omega_{\mathbb{L}})$, then its gauge transform $e^B \mathbb{L}$ keeps the same vector space F and adds $B|_F$ to Ω_L :

$$e^B \mathbb{L}(F, \Omega) = \mathbb{L}(F, \Omega + B|_F).$$

It follows that Dirac structures admit the following decomposition:

Exercise 7.13. Show that any Dirac structure $\mathbb{L} \in \mathfrak{D}(V)$ is of the form (recall Example 7.2)

$$\mathbb{L} = e^{\Omega} \mathbb{L}_F,$$

for a linear subspace $F \subset V$ and a 2-form $\Omega \in \wedge^2 V^*$.

7.2. Dirac structures

Given a manifold M , we can apply the discussion from the previous section to its tangent spaces.

First of all, we obtain the **generalized tangent bundle** of M :

$$\mathbb{T}M := TM \oplus T^*M.$$

We will write a section of $\mathbb{T}M$ as $X + \alpha$, where $X \in \mathfrak{X}(M)$ and $\alpha \in \Omega^1(M)$.

Next, formula (7.1) defines a fiberwise symmetric bilinear 2-form (\cdot, \cdot) on $\mathbb{T}M$, which when applied to global sections yields smooth functions.

Finally, when passing to manifolds there is an additional structure, namely a type of “generalized Lie bracket”,

$$[\cdot, \cdot] : \Gamma(\mathbb{T}M) \times \Gamma(\mathbb{T}M) \rightarrow \Gamma(\mathbb{T}M)$$

called the **Dorfman bracket**. This extends the usual Lie bracket of vector fields and is defined on sections $X + \alpha, Y + \beta \in \Gamma(\mathbb{T}M)$ by

$$[X + \alpha, Y + \beta] := [X, Y] + \mathcal{L}_X \beta - \mathcal{L}_Y \alpha + \text{di}_Y \alpha.$$

Proposition 7.14. *The Dorfman bracket satisfies the following properties for all $s_1, s_2, s_3 \in \Gamma(\mathbb{T}M)$ and all $f \in C^\infty(M)$:*

(i) *The Leibniz-type identity:*

$$[s_1, f s_2] = \mathcal{L}_{\text{pr}_{TM}(s_1)}(f) s_2 + f [s_1, s_2].$$

(ii) It is skew-symmetric up to an exact 1-form:

$$[s_1, s_2] + [s_2, s_1] = d(s_1, s_2).$$

(iii) The Jacobi-type identity:

$$[s_1, [s_2, s_3]] = [[s_1, s_2], s_3] + [s_2, [s_1, s_3]].$$

(iv) It preserves the metric (\cdot, \cdot) :

$$\mathcal{L}_{\text{pr}_{TM}(s_1)}(s_2, s_3) = ([s_1, s_2], s_3) + (s_2, [s_1, s_3]).$$

The Dorfman bracket is **not a Lie bracket** because it is not skew-symmetric, and so $(\Gamma(TM), [\cdot, \cdot])$ is not a Lie algebra. For this reason, the Jacobi identity holds only in the form (iii). The relations above are precisely the axioms of a geometric structure called a *Courant algebroid* — but this falls outside the scope of this book.

Exercise 7.15. Prove the identities in Proposition 7.14.

An **almost Dirac structure** on M is a subbundle $\mathbb{L} \subset TM$ such that \mathbb{L}_x is a Dirac structure on the vector space $T_x M$ for each $x \in M$.

Definition 7.16. A **Dirac structure** on M is an almost Dirac structure $\mathbb{L} \subset TM$ that is closed under the Dorfman bracket:

$$[s_1, s_2] \in \Gamma(\mathbb{L}), \quad \forall s_1, s_2 \in \Gamma(\mathbb{L}).$$

A pair (M, \mathbb{L}) is called a **Dirac manifold**.

Remark 7.17. If \mathbb{L} is a Dirac structure on M , then $(s_1, s_2) = 0$ for all $s_1, s_2 \in \Gamma(\mathbb{L})$. Therefore, by Proposition 7.14, the Dorfman bracket restricts to a skew-symmetric bracket on $\Gamma(\mathbb{L})$ yielding the Lie algebra $(\Gamma(\mathbb{L}), [\cdot, \cdot])$.

Example 7.18 (Tangent bundle). The tangent bundle $\mathbb{L} = TM$ is a Dirac structure. The restriction of the Dorfman bracket to $\Gamma(\mathbb{L}) = \mathfrak{X}(M)$ is the usual Lie bracket of vector fields. 

Example 7.19 (Cotangent bundle). The cotangent bundle $\mathbb{L} = T^*M$ is also a Dirac structure. The restriction of the Dorfman bracket to $\Gamma(\mathbb{L}) = \Omega^1(M)$ is the zero bracket on 1-forms. 

Besides these two extreme examples, more interesting and relevant examples are provided by the global versions of Examples 7.2, 7.3, and 7.5 (subspaces, 2-forms, and bivectors).

Example 7.20 (Foliations). Following Example 7.2, any distribution $\mathcal{D} \subset TM$ gives rise to an almost Dirac structure

$$\mathbb{L}_{\mathcal{D}} := \mathcal{D} \oplus \mathcal{D}^\circ \subset TM.$$

Notice that $\mathbb{L}_{\mathcal{D}}$ is a Dirac structure on M if and only if \mathcal{D} is involutive. By Frobenius's Theorem, Theorem C.3, this is equivalent to $\mathcal{D} = T\mathcal{F}$, for a foliation \mathcal{F} on M . Thus foliations are examples of Dirac structures. 

Example 7.21 (Closed 2-forms). Following Example 7.3, any differential 2-form $\omega \in \Omega^2(M)$ gives rise to an almost Dirac structure

$$\mathbb{L}_{\omega} = \{v + i_v\omega : v \in TM\}.$$

We claim that \mathbb{L}_{ω} is a Dirac structure if and only if ω is a closed 2-form. First note that the Dorfman bracket can also be written as

$$[X + \alpha, Y + \beta] = [X, Y] + \mathcal{L}_X\beta - i_Y d\alpha.$$

Therefore, for all $X, Y \in \mathfrak{X}(M)$ we have that

$$\begin{aligned} [X + i_X\omega, Y + i_Y\omega] &= [X, Y] + \mathcal{L}_X i_Y\omega - i_Y d i_X\omega \\ &= [X, Y] + (\mathcal{L}_X i_Y - i_Y \mathcal{L}_X)\omega + i_Y i_X d\omega \\ &= [X, Y] + i_{[X, Y]}\omega + i_Y i_X d\omega, \end{aligned}$$

where we have used the relations

$$\mathcal{L}_Y = d i_Y + i_Y d \quad \text{and} \quad \mathcal{L}_X i_Y - i_Y \mathcal{L}_X = i_{[X, Y]}.$$

We conclude that $\Gamma(\mathbb{L}_{\omega})$ is closed under the Dorfman bracket if and only if, for all $X, Y \in \mathfrak{X}(M)$, $i_Y i_X d\omega = 0$. This is equivalent to $d\omega = 0$, as claimed.

Thus, every closed 2-form can be regarded as a Dirac structure on M . As in the linear case, Dirac structures of this type can be recognized as those which are transverse to T^*M . Using the isomorphism $\mathbb{L}_{\omega} \simeq TM$ induced by pr_{TM} , one sees that the Lie algebra induced by the Dorfman bracket on $\Gamma(\mathbb{L}_{\omega})$ is isomorphic to $(\mathfrak{X}(M), [\cdot, \cdot])$. 

Example 7.22 (Bivectors). As in Example 7.5, any bivector field $\pi \in \mathfrak{X}^2(M)$ gives rise to an almost Dirac structure

$$\mathbb{L}_{\pi} = \{\pi^{\sharp}\alpha + \alpha : \alpha \in T^*M\}.$$

Similar to the previous example, \mathbb{L}_{π} is a Dirac structure if and only if π is a Poisson bivector. Actually, the computation necessary to check this reveals the existence of the bracket $[\cdot, \cdot]_{\pi}$ on 1-forms (see (2.9))

$$\begin{aligned} [\pi^{\sharp}\alpha + \alpha, \pi^{\sharp}\beta + \beta] &= [\pi^{\sharp}\alpha, \pi^{\sharp}\beta] + \mathcal{L}_{\pi^{\sharp}\alpha}\beta - \mathcal{L}_{\pi^{\sharp}\beta}\alpha + d(\alpha, \pi^{\sharp}\beta) \\ &= [\pi^{\sharp}\alpha, \pi^{\sharp}\beta] + [\alpha, \beta]_{\pi}, \end{aligned}$$

and this belongs to $\Gamma(\mathbb{L}_{\pi})$ if and only if $\pi^{\sharp}[\alpha, \beta]_{\pi} = [\pi^{\sharp}\alpha, \pi^{\sharp}\beta]$. By item (b) in Proposition 2.11, this condition is equivalent to π being a Poisson structure. Thus, Poisson bivectors are particular examples of Dirac structures.

As in the linear case, Dirac structures of this type can be recognized as those which are transverse to TM . Using the isomorphism $\mathbb{L}_{\pi} \simeq T^*M$

induced by pr_{T^*M} , one sees that the Lie algebra structure induced by the Dorfman bracket on $\Gamma(\mathbb{L}_\pi)$ is isomorphic to $(\Omega^1(M), [\cdot, \cdot]_\pi)$, a Lie algebra we have discussed and used in the previous chapters. 

Define the **Poisson support** of a Dirac structure \mathbb{L} on M as the open set where the kernel of \mathbb{L} is trivial:

$$(7.5) \quad \text{Poisson support of } \mathbb{L} := \{x \in M : \mathbb{L}_x \cap T_x M = 0\}.$$

The Poisson support is precisely the set of points $x \in M$ where \mathbb{L}_x is the graph of a bivector π_x . By the description of π_x from Example 7.5, the resulting bivector field π on the Poisson support is smooth. Thus, the previous example yields:

Corollary 7.23. *The restriction of a Dirac structure \mathbb{L} to its Poisson support U is induced by a Poisson structure $\pi \in \mathfrak{X}^2(U)$; i.e., $\mathbb{L}|_U = \mathbb{L}_\pi$.*

Exercise 7.24. Given a closed 2-form $\omega \in \Omega^2(M)$, show that the Poisson support of the associated Dirac structure \mathbb{L}_ω is the open set where ω is nondegenerate.

Example 7.25. Sometimes singular Poisson structures may be turned into nonsingular objects, provided one uses Dirac structures. For a concrete example, take $M = \mathbb{R}^3$ and consider

$$\pi = \frac{1}{z} \frac{\partial}{\partial x} \wedge \frac{\partial}{\partial y}.$$

This is a Poisson structure on $\mathbb{R}^2 \times (\mathbb{R} \setminus \{0\})$ which is not defined at $z = 0$. However, interpreting it as a Dirac structure, i.e., looking at its graph

$$\mathbb{L}_\pi = \text{Span} \left\{ \frac{\partial}{\partial y} + z dx, \frac{\partial}{\partial x} - z dy, dz \right\},$$

we see that it extends as a Dirac structure \mathbb{L} on the entire \mathbb{R}^3 . Note that \mathbb{L} is uniquely determined by π . The Poisson support of \mathbb{L} is $\mathbb{R}^2 \times (\mathbb{R} \setminus \{0\})$ and the kernel of \mathbb{L} on the plane $z = 0$ is

$$(\mathbb{L} \cap T\mathbb{R}^3)_{(x,y,0)} = \text{Span} \left\{ \frac{\partial}{\partial y}, \frac{\partial}{\partial x} \right\}. \quad \img alt="fish icon" data-bbox="825 770 855 788"/>$$

The discussion on vector spaces from the previous section — see Proposition 7.8 — suggests associating to any Dirac structure \mathbb{L} on M

- (i) a subbundle $\text{pr}_{TM}(\mathbb{L}) \subset TM$,
- (ii) a 2-form $\omega_{\mathbb{L}}$ along $\text{pr}_{TM}(\mathbb{L})$, pointwise given by formula (7.2).

We say that \mathbb{L} is a **regular Dirac structure** if $\text{pr}_{TM}(\mathbb{L})$ has constant rank. Generalizing Theorem 4.13 for Poisson structures, we now have:

Proposition 7.26. *On any manifold M there is a 1-to-1 correspondence*

$$\left\{ \begin{array}{l} \text{regular Dirac} \\ \text{structures } \mathbb{L} \text{ on } M \end{array} \right\} \xleftrightarrow{\sim} \left\{ \begin{array}{l} \text{foliations } \mathcal{F} \text{ on } M \text{ together with a} \\ \text{closed foliated 2-form } \omega \in \Omega^2(\mathcal{F}) \end{array} \right\}.$$

The Dirac structure corresponding to the pair (\mathcal{F}, ω) is

$$(7.6) \quad \mathbb{L}(\mathcal{F}, \omega) := \{v + \alpha : v \in T\mathcal{F}, \alpha|_{T\mathcal{F}} = i_v\omega\}.$$

As in the case of Poisson structures, even when \mathbb{L} is not regular, the singular distribution $\text{pr}_{TM}(\mathbb{L})$ is integrable and one can still talk about the leaves of \mathbb{L} . These are immersed connected submanifolds $S \subset M$ such that

$$T_x S = \text{pr}_{TM}(\mathbb{L}_x), \quad \forall x \in S,$$

and which are maximal with respect to this property. The details of these constructions are similar to those from the Poisson case and are left as exercises — see Problems 7.12 and 7.13. Next, the induced 2-form along $\text{pr}_{TM}(\mathbb{L})$, defined pointwise by (7.2), gives rise to a closed 2-form on each leaf S of \mathbb{L}

$$\omega_S \in \Omega^2(S).$$

We call ω_S the **presymplectic form** on S and the pairs (S, ω_S) are called the **presymplectic leaves** of the Dirac manifold (M, \mathbb{L}) . The partition into leaves and the closed 2-form can now be used to describe the Dirac structure:

Proposition 7.27. *Let $\{(F, \omega_F)\}_{F \in \mathcal{F}}$ be a partition of M by connected, immersed submanifolds $F \subset M$ endowed with closed 2-forms ω_F . If*

$$\mathbb{L}_x := \mathbb{L}(T_x F, \omega_{F,x}) \in \mathfrak{D}(T_x M), \quad x \in F \in \mathcal{F},$$

is an almost Dirac structure, then \mathbb{L} is a Dirac structure and its presymplectic leaves are the given family $\{(F, \omega_F)\}_{F \in \mathcal{F}}$.

In Dirac geometry, there are two types of morphisms according to what we saw in the linear case — see (7.3) and (7.4):

Definition 7.28. Let (M, \mathbb{L}_M) and (N, \mathbb{L}_N) be Dirac manifolds. A smooth map $\Phi : M \rightarrow N$ is called

- **forward Dirac** if

$$\mathbb{L}_{N, \Phi(x)} = (d_x \Phi)_! (\mathbb{L}_{M,x}), \quad \forall x \in M,$$

- **backward Dirac** if

$$\mathbb{L}_{M,x} = (d_x \Phi)^! (\mathbb{L}_{N, \Phi(x)}), \quad \forall x \in M.$$

Poisson and symplectic maps are special cases of Dirac maps:

Example 7.29. If $\pi_M \in \mathfrak{X}^2(M)$ and $\pi_N \in \mathfrak{X}^2(N)$ are Poisson bivectors, then a map $\Phi : (M, \mathbb{L}_{\pi_M}) \rightarrow (N, \mathbb{L}_{\pi_N})$ is a forward Dirac map if and only if Φ is a Poisson map.

Similarly, if $\omega_M \in \Omega^2(M)$ and $\omega_N \in \Omega^2(N)$ are closed 2-forms, then a map $\Phi : (M, \mathbb{L}_{\omega_M}) \rightarrow (N, \mathbb{L}_{\omega_N})$ is a backward Dirac map if and only if $\omega_M = \Phi^*(\omega_N)$.

Exercise 7.30. Show that the inclusion of a symplectic leaf is both a forward and a backward Dirac map $i : (S, \mathbb{L}_{\omega_S}) \rightarrow (M, \mathbb{L}_{\pi})$.

We will look closer at the two notions of Dirac maps in the next sections. For now we consider a situation when these two notions come together: diffeomorphisms between Dirac structures. Although this notion is rather obvious, it is still useful to spell it out explicitly. First of all, note that any diffeomorphism $\Phi : M \xrightarrow{\sim} N$ has an associated **generalized differential** $d\Phi : \mathbb{T}M \rightarrow \mathbb{T}N$ given by

$$d_x\Phi := d_x\Phi + ((d_x\Phi)^{-1})^* : \mathbb{T}_xM \rightarrow \mathbb{T}_{\Phi(x)}N.$$

At the level of sections, $d\Phi$ induces a pullback map

$$(d\Phi)^* : \Gamma(\mathbb{T}N) \rightarrow \Gamma(\mathbb{T}M),$$

and we have

$$(d\Phi)^*(X + \alpha) = \Phi^*(X) + \Phi^*(\alpha), \quad \forall X \in \mathfrak{X}(N), \alpha \in \Omega^1(N),$$

where we made use of the usual pullback of vector fields and of differential forms

$$\Phi^*(X) = (d\Phi)^{-1} \circ X \circ \Phi, \quad \Phi^*(\alpha) = (d\Phi)^* \circ \alpha \circ \Phi.$$

Since $d\Phi$ also preserves the pairing (\cdot, \cdot) and the Dorfman bracket, it follows that $d\Phi$ takes Dirac structures to Dirac structures. Two Dirac structures related in this way are called **diffeomorphic Dirac structures**.

7.3. Pullbacks of Dirac structures

Recall that $\Phi : (M, \mathbb{L}_M) \rightarrow (N, \mathbb{L}_N)$ is a backward Dirac map if

$$\mathbb{L}_{M,x} = (d_x\Phi)^!(\mathbb{L}_{N,\Phi(x)}) := \{v + (d_x\Phi)^*\alpha \in \mathbb{T}_xM : d_x\Phi(v) + \alpha \in \mathbb{L}_{N,\Phi(x)}\},$$

for all $x \in M$. So Φ and \mathbb{L}_N determine \mathbb{L}_M . The interesting question is:

- Given a smooth map $\Phi : M \rightarrow N$ and a Dirac structure \mathbb{L} on N , can one find a Dirac structure on M making Φ into a backward Dirac map?

Of course, this holds precisely when the family of pointwise pullbacks

$$(\Phi^1\mathbb{L})_x := (d_x\Phi)^!(\mathbb{L}_{\Phi(x)}) \in \mathfrak{D}(\mathbb{T}_xM) \quad (x \in M)$$

defines a Dirac structure on M . As we will see, the only problem is that $\Phi^1\mathbb{L}$ may fail to be a smooth subbundle of $\mathbb{T}M$, since then being closed under the Dorfmann bracket will hold.

Example 7.31. When $\mathbb{L} = \mathbb{L}_\omega$ is induced by a 2-form $\omega \in \Omega^2(N)$, the pullback $\Phi^1\mathbb{L}$ is induced by the pullback 2-form $\Phi^*\omega$:

$$\Phi^1\mathbb{L}_\omega = \mathbb{L}_{\Phi^*\omega}.$$

Therefore, $\Phi^1\mathbb{L}_\omega$ is a Dirac structure.

However, for a Poisson bivector field π the pullback $\Phi^1\mathbb{L}_\pi$ may fail to be a smooth subbundle of $\mathbb{T}M$. For example, when $\pi \equiv 0$ the induced Dirac structure is just $\mathbb{L} = T^*N$ and we find that

$$\Phi^1\mathbb{L} = \text{Ker } d\Phi \oplus (\text{Ker } d\Phi)^\circ$$

which is smooth if and only if Φ has constant rank.

Smoothness of the pullback can fail even when Φ has constant rank. For instance, let $M = \mathbb{R}$, $N = \mathbb{R}^2$, and $\Phi(x) = (x, 0)$, and let $\mathbb{L} = \mathbb{L}_\pi$ be the Dirac structure corresponding to the Poisson bivector

$$\pi = x \frac{\partial}{\partial x} \wedge \frac{\partial}{\partial y}.$$

Then we find that

$$(\Phi^1\mathbb{L}_\pi)_x = \begin{cases} T_x\mathbb{R}, & \text{if } x \neq 0, \\ T_0^*\mathbb{R}, & \text{if } x = 0. \end{cases}$$

Hence $\Phi^1\mathbb{L}_\pi$ is not a smooth subbundle of $\mathbb{T}M$.

On the other hand, as we will see below, it is not difficult to show that for a submersion $\Phi^1\mathbb{L}$ is smooth. 

As promised:

Theorem 7.32. *Let $\Phi : M \rightarrow N$ be a smooth map, and let \mathbb{L} be a Dirac structure on N . If $\Phi^1\mathbb{L}$ is a smooth subbundle of $\mathbb{T}M$, then $\Phi^1\mathbb{L}$ is a Dirac structure on M .*

This theorem will be proven together with the next one.

It is natural to expect that the pullback Dirac structure $\Phi^1\mathbb{L}$ has presymplectic leaves the preimages of the presymplectic leaves of \mathbb{L} . A standard assumption which ensures that the preimage of a submanifold is a submanifold is that the map is transverse to the submanifold. Given that presymplectic

leaves are defined as the integral submanifolds of the singular distribution $\text{pr}_{TN}(\mathbb{L})$, the transversality condition becomes

$$d_x\Phi(T_xM) + \text{pr}_{TN}(\mathbb{L}_{\Phi(x)}) = T_{\Phi(x)}N, \quad \forall x \in M.$$

Actually, all that is needed for such arguments to work is that the left-hand side has constant rank — see Theorem C.12.

Theorem 7.33. *Let $\Phi : M \rightarrow N$ be a smooth map, let \mathbb{L} be a Dirac structure on N , and assume that the subspaces*

$$(7.7) \quad d_x\Phi(T_xM) + \text{pr}_{TN}(\mathbb{L}_{\Phi(x)}) \subset T_{\Phi(x)}N \quad (x \in M)$$

have the same dimension. Then $\Phi^!\mathbb{L}$ is a Dirac structure with presymplectic leaves the connected components of $(\Phi^{-1}(S), \Phi^\omega_S)$, where (S, ω_S) ranges over the presymplectic leaves of \mathbb{L} .*

Notice that, by Theorem C.12, in the previous statement there is no ambiguity on the submanifold structure on $\Phi^{-1}(S)$ since it is an initial submanifold of M .

Proof of Theorem 7.33. Note that $\Phi^!\mathbb{L} \subset \mathbb{T}M$ is the image by the map

$$(\text{Id}, \Phi^*) : TM \oplus \Phi^*(T^*N) \rightarrow \mathbb{T}M$$

of the family of subspaces

$$K = \{v + \alpha : d_x\Phi(v) + \alpha \in \mathbb{L}_{\Phi(x)}\} \subset TM \oplus \Phi^*(T^*N).$$

On the other hand, K can be identified with the kernel of the bundle map $TM \oplus \Phi^*(\mathbb{L}) \rightarrow \Phi^*(TN)$ given by

$$(v, w + \alpha) \in T_xM \times \mathbb{L}_{\Phi(x)} \mapsto d_x\Phi(v) - w \in T_{\Phi(x)}N.$$

The hypothesis says that this map has constant rank; hence K is smooth. Therefore $\Phi^!\mathbb{L}$ is smooth also.

Next, notice that the linear pullback operation $A^! : \mathfrak{D}(V_2) \rightarrow \mathfrak{D}(V_1)$ from (7.3) takes a constant Dirac structure of type $\mathbb{L}(F, \Omega)$ associated to (F, Ω) (as in Proposition 7.8) to the one associated to $(A^{-1}(F), A^*\Omega)$. Therefore, if $(S, \omega_S) \subset N$ is a presymplectic leaf of \mathbb{L} , then for all $x \in \Phi^{-1}(S)$

$$(\Phi^!\mathbb{L})_x = \mathbb{L}((d\Phi)^{-1}(T_{\Phi(x)}S), \Phi^*\omega_S) = \mathbb{L}(T_x(\Phi^{-1}(S)), \Phi^*\omega_S).$$

By Proposition 7.27 we deduce that $\Phi^!\mathbb{L}$ is indeed a Dirac structure and its presymplectic foliation consists of the connected components of the presymplectic manifolds $(\Phi^{-1}(S), \Phi^*\omega_S)$. \square

Proof of Theorem 7.32. This follows now from two simple remarks. The first one is that the set U of points in M for which the condition (7.7) from the last theorem is satisfied around the point is dense in M . The second remark is that, for any almost Dirac structure \mathbb{L} on M , to ensure that \mathbb{L}

is closed under the Dorfman bracket it suffices to work over a dense open subset $U \subset M$. Indeed, for $s_1, s_2 \in \Gamma(\mathbb{L})$, the fact that $[s_1, s_2]$ is a section of \mathbb{L} at all points in U clearly implies the same at all points of M . \square

Example 7.34 (Poisson transversals). Let (M, π_M) be a Poisson manifold, and let $X \subset M$ be a Poisson transversal with induced Poisson structure π_X . Then the inclusion $i : (X, \mathbb{L}_{\pi_X}) \hookrightarrow (M, \mathbb{L}_{\pi_M})$ is a backward Dirac map. The description of the symplectic leaves of π_X given in Proposition 5.9 coincides with the description of the leaves of the pullback Dirac structure given in Theorem 7.33. 

Remark 7.35. If $\Phi^!\mathbb{L}$ is smooth but condition (7.7) fails, then the relationship between the presymplectic leaves of \mathbb{L} and $\Phi^!\mathbb{L}$ is more subtle. For example, consider the Dirac structure on \mathbb{R}^3 given by

$$\mathbb{L} = \text{Span} \left\{ \frac{\partial}{\partial x}, dy + z \frac{\partial}{\partial z}, dz - z \frac{\partial}{\partial y} \right\}.$$

Its presymplectic leaves are the lines $S_c = \{y = c, z = 0\}$, $c \in \mathbb{R}$, and the two half-spaces $S_+ = \{z > 0\}$ and $S_- = \{z < 0\}$. The injective immersion $\Phi : \mathbb{R} \rightarrow \mathbb{R}^3, t \mapsto (t, 0, t^2)$ intersects S_0 and S_+ . The pullback Dirac structure exists and is given by $\Phi^!\mathbb{L} = T\mathbb{R}$. So it has only one leaf, which is not of the form $\Phi^{-1}(S)$.

7.4. Pushforwards of Dirac structures

Recall that a map $\Phi : (M, \mathbb{L}_M) \rightarrow (N, \mathbb{L}_N)$ is a forward Dirac map if

$$\mathbb{L}_{N, \Phi(x)} = (d_x \Phi)_!(\mathbb{L}_{M,x}) := \{d_x \Phi(v) + \alpha \in \mathbb{T}_{\Phi(x)}N : v + (d_x \Phi)^* \alpha \in \mathbb{L}_{M,x}\},$$

for all $x \in M$. If this holds, note that \mathbb{L}_M determines \mathbb{L}_N along the image of Φ . The interesting question here is:

- Given a surjective submersion $\Phi : M \rightarrow N$ and a Dirac structure \mathbb{L} on M , is there a Dirac structure on N making Φ into a forward Dirac map?

Of course, we should consider the pointwise pushforwards

$$(7.8) \quad (\Phi_!\mathbb{L})_y := (d_x \Phi)_!(\mathbb{L}_x) \in \mathfrak{D}(\mathbb{T}_y N) \quad (y = \Phi(x)).$$

There are two issues we have to take care of:

- For $\Phi_!\mathbb{L}$ to be well-defined, the subspace $(d_x \Phi)_!(\mathbb{L}_x) \subset \mathbb{T}_y N$ should not depend on the choice of point in the fiber $x \in \Phi^{-1}(y)$. If this is the case, we say that \mathbb{L} is **Φ -invariant**.
- If \mathbb{L} is Φ -invariant, we obtain a well-defined “subbundle”

$$\Phi_!\mathbb{L} \subset \mathbb{T}N,$$

which, as in the case of pullbacks, may fail to be smooth.

As in the case of pullbacks, if both issues can be overcome, the pushforward is a Dirac structure — see Theorem 7.39.

Exercise 7.36. Given a surjective submersion $\Phi : M \rightarrow N$, show that $\Phi_!(TM) = TN$.

In general, because of the Φ -invariance condition, it is more complicated to push forward Dirac structures than to pull them back. We illustrate this with an example which is the analogue of Example 7.31:

Example 7.37. The pullback of Dirac structures induced by 2-forms posed no problems, as it corresponds to the usual pullback of differential forms. However, the pushforward does not always work. For example, consider $\Phi : \mathbb{R}^2 \rightarrow \mathbb{R}$, $\Phi(x, y) = x$, and the Dirac structure induced by

$$\omega := xdx \wedge dy.$$

In this case, the Φ -invariance condition is satisfied but $\Phi_*\mathbb{L}_\omega$ is not smooth.

For the Dirac structure \mathbb{L}_π induced by a Poisson bivector $\pi \in \mathfrak{X}^2(M)$, the condition that \mathbb{L}_π is Φ -invariant is equivalent to π being Φ -projectable, i.e., Φ -related to a bivector field $\Phi_*\pi$ on N . When this holds $\Phi_*\pi$ is a Poisson structure and $\Phi_!\mathbb{L}_\pi = \mathbb{L}_{\Phi_*\pi}$. 

Exercise 7.38. Show that Proposition C.17 is an example of the pushforward as well as of the pullback construction for Dirac structures.

The analogues of Theorems 7.32 and 7.33 hold if Φ -invariance is assumed. We leave the proofs as exercises.

Theorem 7.39. *Let $\Phi : M \rightarrow N$ be a surjective submersion, and let \mathbb{L} be a Dirac structure on M that is Φ -invariant.*

- (i) *If $\Phi_!\mathbb{L}$ is a smooth subbundle, then $\Phi_!\mathbb{L}$ is a Dirac structure on N .*
- (ii) *If $\text{Ker}(d\Phi) \cap \mathbb{L}$ has constant rank, then $\Phi_!\mathbb{L}$ is a Dirac structure.*

Remark 7.40. In this section, we always assume that Φ is a surjective submersion. The first part of the theorem also holds without the assumption that Φ is a submersion. This is because it suffices to check that $\Phi_!\mathbb{L}|_U$ is a Dirac structure, where U is the image of the regular points of Φ , which is dense — by Sard's Theorem — and open. However, the second part of the theorem might fail if Φ is not a submersion. For example, the smooth homeomorphism $\Phi(q, p) = (q^3, p)$ of \mathbb{R}^2 sends the canonical Poisson structure to a nonsmooth bivector field:

$$\Phi_*\left(\frac{\partial}{\partial p} \wedge \frac{\partial}{\partial q}\right) = 3q^{\frac{2}{3}} \frac{\partial}{\partial p} \wedge \frac{\partial}{\partial q}.$$

Example 7.41 (Liebermann's Theorem). The discussion in Example 7.37 implies that the pushforward $\Phi_! \mathbb{L}_\omega$ of a Dirac structure associated to a symplectic form, if it exists, is associated to a Poisson structure. In fact, Lieberman's Theorem, Theorem 6.27, can be seen as a special case of Theorem 7.39: the hypotheses there — connected fibers and involutivity of the distribution that is symplectic orthogonal to the fibers — guarantee that the Dirac structure defined by the symplectic form is invariant under the submersion.



Example 7.42 (Reduction). We have seen that the quotient M/G of a symplectic manifold (M, ω) by a free and proper symplectic action of a Lie group G has an induced Poisson structure π . Since the defining property of π was that the quotient map $p : M \rightarrow M/G$ is a Poisson map, we deduce that the Dirac structure \mathbb{L}_ω can be pushed forward to the Dirac structure \mathbb{L}_π on M/G .

This construction, as well as a slight generalization, can be obtained using the previous theorem. Consider a proper and free action of a Lie group G on M that preserves a closed 2-form ω , which is not necessarily nondegenerate. Denote by $\mathfrak{a} : \mathfrak{g} \rightarrow \mathfrak{X}(M)$ the infinitesimal action. Note that ω being G -invariant implies that \mathbb{L}_ω is p -invariant and that the condition from Theorem 7.39(ii) becomes

$$\text{Ker } \omega \cap \text{Im } \mathfrak{a} \quad \text{has constant rank.}$$

If this condition holds, there is an induced Dirac structure $p_! \mathbb{L}_\omega$ on M/G . According to (7.5), the Poisson support of $p_! \mathbb{L}_\omega$ consists of the points where $T(M/G) \cap p_! \mathbb{L}_\omega = 0$, and this is the image under p of the G -invariant subset consisting of points in M where

$$\text{Ker } \omega \subset \text{Im } \mathfrak{a}.$$

We conclude the following:

Corollary 7.43. *Given a proper free G -action on M preserving a closed 2-form $\omega \in \Omega^2(M)$ of constant rank, if $\text{Ker } \omega \subset \text{Im } \mathfrak{a}$, then there is a unique Poisson structure M/G such that the projection $p : M \rightarrow M/G$ is a forward Dirac map. The resulting Poisson structure is symplectic if and only if*

$$(7.9) \quad \text{Im } \mathfrak{a} \cap (\text{Im } \mathfrak{a})^{\perp \omega} = \text{Ker } \omega.$$

This corollary can be used to understand symplectic reduction from the orbit point of view — as in (B.11). Starting with a G -Hamiltonian space (M, ω) with moment map $\mu : M \rightarrow \mathfrak{g}^*$, assume that the action is proper and free. Then we can restrict ω to $\mu^{-1}(\mathcal{O}_\xi)$ obtaining a G -invariant, closed 2-form, of constant rank. Applying Lemma 1.34, one finds that the kernel

of the restriction is precisely

$$\text{Ker } \omega|_{\mu^{-1}(\mathcal{O}_\xi)} = T(G \cdot x) \cap \text{Ker } d_x \mu \subset \text{Im } \mathfrak{a}.$$

Since (7.9) is satisfied, we obtain a symplectic structure on $\mu^{-1}(\mathcal{O}_\xi)/G$.

Exercise 7.44. Show that the resulting symplectic structure on $\mu^{-1}(\mathcal{O}_\xi)/G$ is symplectic and coincides with the reduced symplectic form on $M //_\xi G$.

We can summarize orbit reduction by a commuting diagram of Dirac manifolds

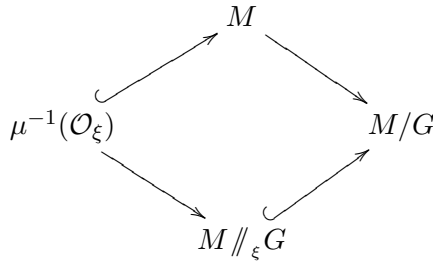

where the inclusions are backward Dirac maps and the projections are forward Dirac maps — see Problem 7.6. 

Example 7.45 (Passing from Dirac to Poisson). Since a Dirac structure \mathbb{L} on M is a Poisson structure if and only if its kernel vanishes, i.e., $\mathbb{L} \cap TM = 0$, one can try to “kill” the kernel to obtain a Poisson structure. For that, one needs two conditions:

- (i) The kernel $\mathbb{L} \cap TM$ has constant rank. It follows that the kernel is an involutive distribution.
- (ii) The foliation defined by the kernel is simple; i.e., there is a surjective submersion with connected fibers $\Phi : M \rightarrow N$, such that $\text{Ker } d\Phi = \mathbb{L} \cap TM$.

We claim that then \mathbb{L} can be pushed forward along $\Phi : M \rightarrow N$ to a Dirac structure on N . The condition in Theorem 7.39(ii) is clearly satisfied, while the Φ -invariance follows by an argument similar to the one in Liberman’s Theorem. Using that Φ is a submersion and using the definition of the pushforward, we obtain

$$(\Phi_! \mathbb{L}) \cap TN = d\Phi(\mathbb{L} \cap TM) = 0.$$

So $\Phi_! \mathbb{L}$ is induced by a Poisson structure π on N .

Exercise 7.46. Show that the resulting map $\Phi : (M, \mathbb{L}) \rightarrow (N, \mathbb{L}_\pi)$ is also a backward Dirac map. 

7.5. Gauge equivalences

We saw in Section 7.2 that the generalized differential $\mathfrak{d}\Phi : \mathbb{T}M \rightarrow \mathbb{T}M$ of a diffeomorphism $\Phi : M \rightarrow M$ preserves the canonical pairing (\cdot, \cdot) and the Dorfman bracket $[\cdot, \cdot]$. In other words, it is an **automorphism of the generalized tangent bundle**. Note that these are the essential properties which ensure that $\mathfrak{d}\Phi$ sends Dirac structures to Dirac structures.

To introduce other automorphisms of $\mathbb{T}M$, we extend Definition 7.12 from vector spaces to manifolds. We define the **gauge transformation** induced by a 2-form $B \in \Omega^2(M)$ as the vector bundle isomorphism

$$e^B : \mathbb{T}M \rightarrow \mathbb{T}M, \quad v + \alpha \mapsto v + \alpha + i_v B.$$

We leave the proof of the following as an exercise.

Lemma 7.47. *The map $e^B : \mathbb{T}M \rightarrow \mathbb{T}M$ preserves the canonical pairing (\cdot, \cdot) . It preserves the Dorfman bracket $[\cdot, \cdot]$ if and only if $\mathfrak{d}B = 0$.*

Hence, any closed 2-form defines an automorphism of the generalized tangent bundle. We show now that there are no other symmetries:

Theorem 7.48. *Let $A : \mathbb{T}M \rightarrow \mathbb{T}M$ be a bundle isomorphism covering a diffeomorphism $\Phi : M \rightarrow M$ and preserving both the canonical pairing (\cdot, \cdot) and the Dorfman bracket $[\cdot, \cdot]$. Then*

$$A = e^B \circ \mathfrak{d}\Phi,$$

for some closed 2-form $B \in \Omega^2(M)$.

Proof. Let $A : \mathbb{T}M \rightarrow \mathbb{T}M$ be as in the statement of the theorem. Then

$$A \circ (\mathfrak{d}\Phi)^{-1} : \mathbb{T}M \rightarrow \mathbb{T}M$$

is also a bundle isomorphism that preserves both the canonical pairing and the Dorfman bracket but which covers the identity. So one can assume that $\Phi = \text{Id}_M$ and one needs to show that $A = e^B$, for some closed 2-form B .

First we show that

$$(7.10) \quad \text{pr}_{\mathbb{T}M} A(Y) = Y, \quad \forall Y \in \mathfrak{X}(M).$$

For this, let $s_1 = X + \alpha$ and $s_2 = Y + \beta$ be sections of the generalized tangent bundle $\mathbb{T}M$. For any $f \in C^\infty(M)$, Proposition 7.14(i) and (ii) imply

$$[f s_1, s_2] = f[s_1, s_2] - \mathcal{L}_Y(f) s_1 + (s_1, s_2) df.$$

Hence, we find that

$$\begin{aligned} A([f s_1, s_2]) &= f A([s_1, s_2]) - \mathcal{L}_Y(f) A(s_1) + (s_1, s_2) A(df), \\ [A(f s_1), A(s_2)] &= f[A(s_1), A(s_2)] - \mathcal{L}_{\text{pr}_{\mathbb{T}M}(A(s_2))}(f) A(s_1) + (A(s_1), A(s_2)) df. \end{aligned}$$

Since A preserves both the pairing and the bracket, we conclude

$$(7.11) \quad -\mathcal{L}_Y(f)A(s_1) + (s_1, s_2)A(df) = -\mathcal{L}_{\text{pr}_{TM}(A(s_2))}(f)A(s_1) + (s_1, s_2)df.$$

Choosing $s_1 = X$ and $s_2 = Y$ so that $(s_1, s_2) = 0$, we see that

$$\mathcal{L}_Y(f)A(X) = \mathcal{L}_{\text{pr}_{TM}(A(Y))}(f)A(X),$$

and so we obtain (7.10).

If we now let $s_1 = \alpha$ and $s_2 = Y$ in (7.11), we also obtain

$$A(df) = df, \quad \forall f \in C^\infty(M).$$

This relation together with (7.10) implies that A is of the form

$$A(X + \alpha) = X + \alpha + N(X),$$

for some bundle map $N : TM \rightarrow T^*M$. Using again that A preserves the canonical pairing, we conclude that $N = B^\flat$ for a 2-form $B \in \Omega^2(M)$. So we have shown that

$$A(X + \alpha) = e^B(X + \alpha) = X + \alpha + i_X B.$$

By Lemma 7.47, A preserves the Dorfman bracket iff B is closed. □

Exercise 7.49. Show that the automorphisms of the generalized tangent bundle $\mathbb{T}M$ form a group isomorphic to the semidirect product,

$$\text{Aut}(\mathbb{T}M) \simeq \text{Diff}(M) \ltimes \Omega_{\text{cl}}^2(M),$$

where $\text{Diff}(M)$ acts on the abelian group $(\Omega_{\text{cl}}^2(M), +)$ via pullback of forms.

Lemma 7.47 implies that the gauge transform $e^B : \mathbb{T}M \rightarrow \mathbb{T}M$ associated to a closed 2-form B maps Dirac structures to Dirac structures.

Definition 7.50. The **gauge transform** of a Dirac structure \mathbb{L} with respect to a closed 2-form $B \in \Omega_{\text{cl}}^2(M)$ is the Dirac structure

$$e^B \mathbb{L} := \{v + \alpha + i_v B : v + \alpha \in \mathbb{L}\}.$$

Two Dirac structures \mathbb{L}_1 and \mathbb{L}_2 are said to be **gauge equivalent** if there exists $B \in \Omega_{\text{cl}}^2(M)$ such that $\mathbb{L}_2 = e^B \mathbb{L}_1$.

If we think of a Dirac structure \mathbb{L} on a manifold M as a (singular) foliation by presymplectic leaves (S, ω_S) , then its gauge transform $e^B \mathbb{L}$ has the same foliation as \mathbb{L} but where the presymplectic form on a leaf S has been transformed to $\omega_S + B|_S$.

Example 7.51 (Gauge transformations of Poisson structures). Definition 5.20 of gauge equivalent Poisson structures is a special instance of the notion of gauge equivalence for Dirac structures: two Poisson structures are

B -gauge equivalent precisely when the associated Dirac structures are B -gauge equivalent. Note also that, given a Poisson structure π , the B -gauge transform of the Dirac structure \mathbb{L}_π is

$$e^B \mathbb{L}_\pi = \{ \pi^\sharp(\alpha) + (I + B^\flat \circ \pi^\sharp)\alpha : \alpha \in T^*M \}.$$

In general, this Dirac structure is not associated with a Poisson structure. Its Poisson support (7.5) is the set of points $x \in M$ for which the map

$$(7.12) \quad I + B^\flat \circ \pi^\sharp : T_x^*M \rightarrow T_x^*M$$

is a linear isomorphism. When the Poisson support is M , then $e^B \mathbb{L}_\pi$ is the Dirac structure associated with the Poisson bivector $\pi_B \in \mathfrak{X}^2(M)$ given by

$$\pi_B^\sharp = \pi^\sharp \circ (I + B^\flat \circ \pi^\sharp)^{-1}.$$

This justifies the use of the notation $e^B \pi$ for π_B . 

Example 7.52 (Gauge transformations of symplectic realizations). Given a symplectic realization $\mu : (S, \omega) \rightarrow (M, \pi)$ and a closed 2-form $B \in \Omega^2(M)$ such $(I + B^\flat \circ \pi^\sharp)$ is invertible, observe the following:

- (i) $\omega + \mu^* B \in \Omega^2(S)$ is still a symplectic form.
- (ii) $\mu : (S, \omega + \mu^* B) \rightarrow (M, e^B \pi)$ is a Poisson map.

Hence, $\mu : (S, \omega + \mu^* B) \rightarrow (M, e^B \pi)$ is a symplectic realization. The following exercise gives a concrete example.

Exercise 7.53. Show that the linear Poisson structure on \mathbb{R}^2 given by $\{x, y\} = x$ is B -gauge equivalent to the Poisson structure given by

$$\{x, y\}_B = x e^{-x},$$

via the closed 2-form (smooth at $x = 0$)

$$B = \frac{1 - e^x}{x} dx \wedge dy.$$

Conclude that $\{\cdot, \cdot\}_B$ has a symplectic realization $\mu : \mathbb{R}^4 \rightarrow \mathbb{R}^2$, $(x, y, u, v) \mapsto (x, y)$, where \mathbb{R}^4 is equipped with the symplectic form

$$\omega_B = \frac{1 - e^x}{x} dx \wedge dy + e^v (du \wedge dx + x du \wedge dv) + dv \wedge dy.$$

(HINT: Use a symplectic realization from Section 6.3.) 

Example 7.54 (Coupling construction). The coupling construction in Section 4.4 can be better understood in terms of Dirac structures and their gauge transformations. There, starting with a principal G -bundle over a symplectic manifold, $p : P \rightarrow (S, \omega_S)$, endowed with a connection 1-form

$\theta \in \Omega^1(P, \mathfrak{g})$, we have constructed a Poisson manifold

$$(7.13) \quad (M^\theta(P, \omega_S), \pi^\theta)$$

that sits inside $P \times_G \mathfrak{g}^*$ as an open neighborhood of $S \simeq P \times_G 0$.

Here is the description of the coupling construction in the framework of Dirac structures:

- (i) The connection $\theta \in \Omega^1(P, \mathfrak{g})$ can be seen as a 1-form $\tilde{\theta}$ on $P \times \mathfrak{g}^*$ and, together with the symplectic form $\omega_S \in \Omega^2(S)$, they yield a closed, G -invariant 2-form:

$$\Omega := p^*\omega_S - d\tilde{\theta} \in \Omega^2(P \times \mathfrak{g}^*).$$

The graph of this 2-form can be pushed forward to a Dirac structure

$$\mathbb{L}^\theta := \text{pr}_!(\mathbb{L}_\Omega) \subset \mathbb{T}(P \times_G \mathfrak{g}^*).$$

- (ii) The coupling Poisson structure (7.13) is precisely the Poisson support (7.5) of \mathbb{L}^θ

$$M^\theta(P, \omega_S) = \text{Poisson support of } \mathbb{L}^\theta, \\ \mathbb{L}_{\pi^\theta} = \mathbb{L}^\theta|_{M^\theta(P, \omega_S)}.$$

- (iii) If θ' is another principal bundle connection, then \mathbb{L}^θ and $\mathbb{L}^{\theta'}$ are gauge equivalent with respect to $B = d(\tilde{\theta} - \tilde{\theta}')$. By Moser's Lemma — in the form of Theorem 5.22 — the germ of π^θ near S is independent of the choice of connection, up to Poisson diffeomorphisms.

In conclusion, the coupling construction, when viewed as a Dirac structure, makes sense globally on $P \times_G \mathfrak{g}^*$ and is unique up to exact gauge transformations. From the Poisson perspective, the Poisson structure π^θ , which can be defined only around S , naturally extends as a Dirac structure \mathbb{L}^θ to the entire $P \times_G \mathfrak{g}^*$.

Exercise 7.55. Justify (i) and (ii) above by showing the following:

- (a) $\text{Ker } \Omega \cap \text{Im } \varrho = 0$ holds everywhere on $P \times \mathfrak{g}^*$.
- (b) The Poisson support of L^θ is the image under p of the nondegeneracy locus of Ω .

(HINT: Look at Example 7.42 and Exercise 4.26.)



Problems

7.1. Let $\mathbb{L} \in \mathfrak{D}(V)$ be a Dirac structure, and let $D \subset V$ be a subspace complementary to the kernel of \mathbb{L}

$$V = (\mathbb{L} \cap V) \oplus D.$$

Show that the Dirac structure $\mathbb{L}_D = D \oplus D^\circ$ is complementary to \mathbb{L} :

$$\mathbb{V} = \mathbb{L} \oplus \mathbb{L}_D.$$

7.2. Consider a section $s \in \Gamma(\mathbb{T}M)$. Show that the operation

$$\text{ad}_s := [s, \cdot] : \Gamma(\mathbb{T}M) \rightarrow \Gamma(\mathbb{T}M)$$

is a derivation of the Dorfman bracket and the canonical pairing:

$$\begin{aligned} \text{ad}_s([s_1, s_2]) &= [\text{ad}_s s_1, s_2] + [s_1, \text{ad}_s s_2], \\ \mathcal{L}_{\text{pr}_{TM}(s)}(s_1, s_2) &= (\text{ad}_s s_1, s_2) + (s_1, \text{ad}_s s_2). \end{aligned}$$

7.3. The Courant bracket is defined as the antisymmetrization of the Dorfman bracket, so it is given on sections $X + \alpha, Y + \beta \in \Gamma(\mathbb{T}M)$ by

$$\llbracket X + \alpha, Y + \beta \rrbracket := [X, Y] + \mathcal{L}_X \beta - \mathcal{L}_Y \alpha + \frac{1}{2} d(i_Y \alpha - i_X \beta).$$

Show that this bracket is

(a) skew-symmetric: $\llbracket s_1, s_2 \rrbracket = -\llbracket s_2, s_1 \rrbracket$,

but that it fails to satisfy the other relations in the following controlled way:

(b) failure of the Leibniz rule:

$$\llbracket s_1, f s_2 \rrbracket = f \llbracket s_1, s_2 \rrbracket + \mathcal{L}_{\text{pr}_{TM}(s_1)}(f) s_2 - \frac{1}{2} (s_1, s_2) df,$$

(c) failure to be compatible with the metric:

$$\begin{aligned} \mathcal{L}_{\text{pr}_{TM}(s_1)}(s_2, s_3) &= (\llbracket s_1, s_2 \rrbracket, s_3) + (s_2, \llbracket s_1, s_3 \rrbracket) \\ &\quad + \frac{1}{2} (d(s_1, s_2), s_3) + \frac{1}{2} (s_2, d(s_1, s_3)), \end{aligned}$$

(d) failure to satisfy the Jacobi identity:

$$\begin{aligned} &\llbracket s_1, \llbracket s_2, s_3 \rrbracket \rrbracket + \llbracket s_2, \llbracket s_3, s_1 \rrbracket \rrbracket + \llbracket s_3, \llbracket s_1, s_2 \rrbracket \rrbracket \\ &= -\frac{1}{6} d((s_1, \llbracket s_2, s_3 \rrbracket) + (s_2, \llbracket s_3, s_1 \rrbracket) + (s_3, \llbracket s_1, s_2 \rrbracket)), \end{aligned}$$

for all $s_1, s_2, s_3 \in \Gamma(\mathbb{T}M)$ and all $f \in C^\infty(M)$.

7.4. Consider the Courant bracket of the previous problem. Show the following:

- (a) A maximal isotropic subbundle $\mathbb{L} \subset \mathbb{T}M$ is closed under the Courant bracket if and only if it is closed under the Dorfman bracket.
- (b) For a Dirac structure $\mathbb{L} \subset \mathbb{T}M$, the Courant bracket and the Dorfman bracket induce the same operation on $\Gamma(\mathbb{L})$.

7.5. Prove Theorem 7.39.

7.6. Consider a commutative diagram of manifolds

$$\begin{array}{ccc} M & \xrightarrow{j} & N \\ i \downarrow & & \downarrow k \\ P & \xrightarrow{l} & Q \end{array}$$

which is a *strong* pullback, in the sense that

$$M = \{(x, y) \in N \times P : k(x) = l(y)\}, \quad j = \text{pr}_N|_M, \quad i = \text{pr}_P|_M,$$

and k and l are transverse:

$$\text{Im } d_x k + \text{Im } d_y l = T_{k(x)}Q, \quad \forall (x, y) \in M.$$

Consider Dirac structures on these manifolds such that k and i are backward Dirac maps and l is a forward Dirac map. Prove that j is also a forward Dirac map.

7.7. Prove Lemma 7.47.

7.8. Let $(M_1, \pi_1) \xleftarrow{\mu_1} (S, \omega) \xrightarrow{\mu_2} (M_2, -\pi_2)$ be a dual pair. Prove that the corresponding Dirac structures are related by

$$\mu_1^! \mathbb{L}_{\pi_1} = e^\omega \mu_2^! \mathbb{L}_{\pi_2}.$$

7.9. Prove the following generalization of Libermann’s Theorem: Consider a surjective submersion with connected fibers $\mu : S \rightarrow M$ and a Dirac structure \mathbb{L} on S . Then M admits a Dirac structure such that μ is a forward Dirac map if and only if the family

$$x \mapsto (d_x \mu)^!(d_x \mu)_! \mathbb{L}_x \in \mathbb{T}_x S \quad (x \in S)$$

defines a Dirac structure on S . Recover Libermann’s Theorem from this statement.

7.10. Define the flow of a section $s = X + \alpha \in \Gamma(\mathbb{T}M)$ as the 1-parameter family

$$\Phi_s^t := d\phi_X^t \circ e^{d\beta t} : \mathbb{T}D_t \rightarrow \mathbb{T}D_{-t}$$

where $D_t \subset M$ is the domain of existence of the flow $\phi_X^t : D_t \rightarrow D_{-t}$ and

$$\beta_t := \int_0^t (\phi_X^\varepsilon)^* \alpha \, d\varepsilon \in \Omega^1(D_t).$$

For a section $\tilde{s} \in \Gamma(\mathbb{T}M)$, we denote the pullback by the flow of s by

$$(\Phi_s^t)^* \tilde{s} := e^{-d\beta_t} (\phi_X^t)^* \tilde{s} \in \Gamma(\mathbb{T}D_t).$$

Show the following:

(a) The flow can also be written as

$$\Phi_s^t = e^{d\gamma_t} \circ d\phi_X^t, \quad \text{where } \gamma_t = \int_0^t (\phi_X^{-\varepsilon})^* \alpha \, d\varepsilon \in \Omega^1(D_{-t}).$$

(b) For all $t_1, t_2 \in \mathbb{R}$,

$$\Phi_s^{t_1} \circ \Phi_s^{t_2} = \Phi_s^{t_1+t_2}.$$

(c) For all $\tilde{s} \in \Gamma(\mathbb{T}M)$,

$$\frac{d}{dt} (\Phi_s^t)^* \tilde{s} = (\Phi_s^t)^* [s, \tilde{s}].$$

(d) If $(s, s) = 0$, for all $\tilde{s} \in \Gamma(\mathbb{T}M)$,

$$\frac{d}{dt} (\Phi_s^t)^* \tilde{s} = [s, (\Phi_s^t)^* \tilde{s}].$$

7.11. Let \mathbb{L} be a Dirac structure. Show that the flow of a section $s \in \Gamma(\mathbb{L})$, defined in the previous problem, preserves \mathbb{L} :

$$\Phi_s^t(\mathbb{L}_x) = \mathbb{L}_{\phi_X^t(x)}.$$

7.12. Let (M, \mathbb{L}) be a Dirac manifold. Define the rank of \mathbb{L} at $x \in M$ by

$$\text{rank}(\mathbb{L}_x) := \dim(\text{pr}_{TM}(\mathbb{L}_x)).$$

Prove the following local splitting theorem around x : if $\text{rank}(\mathbb{L}_x) = r$, then there are local coordinates $(U, x^1, \dots, x^r, y^1, \dots, y^s)$ for M centered at x and a closed 2-form $B \in \Omega^2(U)$ such that

$$e^B \mathbb{L}|_U = \text{Span} \left\{ \frac{\partial}{\partial x^i}, \sum_{b=1}^s \pi^{ab}(y) \frac{\partial}{\partial y^b} + dy^a : 1 \leq i \leq r, 1 \leq a \leq s \right\},$$

for certain smooth functions $\pi^{ij}(y)$ with $\pi^{ij}(0) = 0$. In other words,

$$(U, e^B \mathbb{L}|_U) \simeq (V, TV) \times (W, \mathbb{L}_\pi),$$

where $\dim V = \text{rank}(\mathbb{L}_x)$ and π vanishes at x .

HINT: As in the proof of Theorem 3.2, proceed by induction on r . For $r \geq 1$, take $X + \alpha$ a local section of \mathbb{L} with $X_x \neq 0$. Apply the flow box theorem to X (or Lemma 3.3), and then find a closed 2-form B_1 such that X is a section of $e^{B_1} \mathbb{L}$. Show that, around x , $e^{B_1} \mathbb{L}$ splits as $(I, TI) \times (W, \mathbb{L}')$, where $I \subset \mathbb{R}$ is an open interval and (W, \mathbb{L}') is a Dirac manifold with $\text{rank}(\mathbb{L}'_x) = r - 1$.

7.13. Mimicking the proof of Theorem 4.1, use the previous problem to prove that a Dirac structure \mathbb{L} on a manifold M defines a presymplectic foliation of M , where the following hold:

- (a) The leaf S thorough $x \in M$ is the set of points y that can be reached from x by a composition of flows of vector fields in $\text{pr}_{TM}(\Gamma(\mathbb{L}))$:

$$S = \{y = \phi_{X_1}^1 \circ \cdots \circ \phi_{X_n}^1(x) : X_i + \alpha_i \in \Gamma(\mathbb{L})\}.$$

- (b) The leaves integrate the singular distribution $\text{pr}_{TM}(\mathbb{L})$; i.e., the tangent space of the leaf S through x is $T_x S = \text{pr}_{TM}(\mathbb{L}_x)$.

- (c) The leaf S through $x \in M$ carries a presymplectic form given by

$$\omega_S(v, w) := \beta(v) = -\alpha(w), \quad \text{if } v, w \in T_x S,$$

where $\alpha, \beta \in T_x^* M$ are any covectors such that $v + \alpha, w + \beta \in \mathbb{L}_x$.

7.14. Let $H \in \Omega_{\text{cl}}^3(M)$ be a closed 3-form. “Twist” the Dorfman bracket as follows:

$$[X + \alpha, Y + \beta]_H := [X + \alpha, Y + \beta] + i_X i_Y H,$$

for $X + \alpha, Y + \beta \in \Gamma(\mathbb{T}M)$. Show that this operation satisfies all the properties listed in Proposition 7.14. What are H -twisted Dirac structures? If $H = dB$, can you relate H -twisted Dirac structures to ordinary ones?

Submanifolds in Poisson Geometry

On a Poisson manifold (M, π) there are several interesting ways in which the Poisson tensor π can interact with a submanifold $N \subset M$. Already in symplectic geometry one encounters symplectic submanifolds, Lagrangian submanifolds, coisotropic submanifolds, etc. For a Poisson manifold (M, π) the various types of submanifolds N are controlled by the π -orthogonal to N , which was defined in Definition 5.2 as

$$(TN)^{\perp\pi} := \pi^{\sharp}((TN)^{\circ}).$$

We have encountered so far two types of submanifolds: symplectic leaves, for which $(TN)^{\perp\pi} = \{0\}$, and Poisson transversals, for which $T_N M = TN \oplus (TN)^{\perp\pi}$. We now look at other interesting types of submanifolds.

8.1. Poisson submanifolds

For any symplectic leaf (S, ω_S) of a Poisson manifold (M, π) , Corollary 4.8 shows that the inclusion $i : (S, \omega_S^{-1}) \hookrightarrow (M, \pi)$ is a Poisson map. We set:

Definition 8.1. A **Poisson submanifold** of a Poisson manifold (M, π) is a Poisson manifold (N, π_N) together with an injective immersion $i : N \hookrightarrow M$ which is a Poisson map.

The nicest case is that of **embedded Poisson submanifolds**, i.e., when $N \subset M$ is an embedded submanifold and i is the inclusion. In general, we have **immersed Poisson submanifolds** $i : N \hookrightarrow M$ which we still identify with their image $i(N)$, so that one can assume that the map i is

the inclusion and $T_x N$ is identified with the subspace $d_x i(T_x N)$ of $T_{i(x)} M$. However, one has to keep in mind that, in general, the topology on N is not the topology induced from M .

Proposition 8.2. *Let (M, π) be a Poisson manifold. Given an immersed submanifold $N \hookrightarrow M$ there is at most one Poisson structure π_N on N that makes (N, π_N) into a Poisson submanifold. This happens if and only if any of the following equivalent conditions hold:*

- (i) $\text{Im } \pi_x^\sharp \subset T_x N$, for all $x \in N$.
- (ii) $(TN)^{\perp \pi} = 0$.
- (iii) Every Hamiltonian vector field $X_H \in \mathfrak{X}(M)$ is tangent to N .

When N is an embedded submanifold, these condition are also equivalent to the following:

- (vi) The vanishing ideal of N

$$\mathcal{I}(N) := \{f \in C^\infty(M) : f(x) = 0, \forall x \in N\}$$

is a Lie algebra ideal; i.e., $\{f, g\} \in \mathcal{I}(N)$ whenever $f \in \mathcal{I}(N)$ and $g \in C^\infty(M)$.

In particular, a Poisson submanifold $N \hookrightarrow M$ intersects each symplectic leaf S of (M, π) in an open subset of S . The connected components of the intersections $N \cap S$ are the symplectic leaves of (N, π_N) .

Proof. If $i : (N, \pi_N) \hookrightarrow (M, \pi)$ is a Poisson submanifold, then π_N is i -related to π :

$$d_x i(\pi_{N,x}) = \pi_x, \quad \forall x \in N,$$

or equivalently,

$$(8.1) \quad d_x i \circ \pi_{N,x}^\sharp \circ (d_x i)^* = \pi_x^\sharp, \quad \forall x \in N.$$

Since $d_x i$ is injective, this shows that π_N is unique. It also shows that (i) must hold if (N, π_N) is a Poisson submanifold.

Next, let $i : N \hookrightarrow M$ be a submanifold such that $\text{Im } \pi_x^\sharp \subset d_x i(T_x N)$. We claim that there exists a unique smooth bivector field π_N on N such that (8.1) holds. Since $\text{Im } \pi_x^\sharp \subset d_x i(T_x N)$, it is enough to check that for any $\alpha \in (T_x N)^\circ = \text{Ker}(d_x i)^*$ we have $\pi_x^\sharp(\alpha) = 0$. This follows by skew-symmetry, as for any $\beta \in T_x^* M$,

$$\langle \pi_x^\sharp(\alpha), \beta \rangle = -\langle \alpha, \pi_x^\sharp(\beta) \rangle = 0.$$

Uniqueness also implies that $(\pi_{N,x}^\sharp)^* = -\pi_{N,x}^\sharp$. The smoothness of π_N is automatic.

Now observe that $[\pi_N, \pi_N] = 0$. In fact, by Proposition 2.15 the Schouten brackets of i -related multivector fields are also i -related:

$$(d_x i)([\pi_N, \pi_N]_x) = [\pi, \pi]_{i(x)} = 0.$$

Since i is an immersion, the result follows. This shows that if (i) holds, then N has a unique Poisson structure such that it is a Poisson submanifold.

For the equivalence between (i) and (ii), observe that using

$$\langle \pi_x^\sharp(\alpha), \beta \rangle = -\langle \alpha, \pi_x^\sharp(\beta) \rangle,$$

with $\alpha \in (T_x N)^\circ$ and $\beta \in T_x^* M$, we obtain that

$$(T_x N)^\perp \pi = \pi_x^\sharp((T_x N)^\circ) = 0 \iff \pi_x^\sharp(T_x^* M) \subset T_x N.$$

The equivalence between (i) and (iii) is obvious.

Finally, if N is an embedded submanifold, a vector field $X \in \mathfrak{X}(M)$ is tangent to N if and only if $\mathcal{L}_X(f) \in \mathcal{I}(N)$, for any $f \in \mathcal{I}(N)$. Hence, in this case, the equivalence between (iii) and (iv) follows from the relation $\{f, g\} = -\mathcal{L}_{X_g}(f)$. \square

Exercise 8.3. What can one say about the equivalence with (iv) in the proposition if the submanifold is not embedded?

Exercise 8.4. Prove the claim about the symplectic leaves from the proposition.

(HINT: Use Theorem C.12 and Proposition 1.8.)

Corollary 8.5. *If $N_1, N_2 \subset (M, \pi)$ are two Poisson submanifolds that intersect cleanly, i.e., $N_1 \cap N_2$ is a submanifold with $T(N_1 \cap N_2) = TN_1 \cap TN_2$, then $N_1 \cap N_2$ is also a Poisson submanifold.*

From Proposition 5.26 one also obtains immediately the following relationship between Poisson submanifolds and Poisson transversals (labeled PTs in the following diagram).

Corollary 8.6. *Consider a Poisson transversal (X, π_X) and a Poisson submanifold (N, π_N) in a Poisson manifold (M, π) . Then:*

- (i) N and X intersect transversally.
- (ii) $X \cap N$ is a Poisson transversal in (N, π_N) .
- (iii) $X \cap N$ is a Poisson submanifold of (X, π_X) .

Moreover, the Poisson structures induced on $X \cap N$ in (ii) and (iii) coincide:

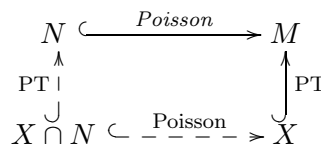

Remark 8.7. Notice a simple, but interesting, geometric consequence of the previous corollary: any Poisson submanifold containing a Poisson transversal must be an open set.

The following exercise gives another geometric description of Poisson submanifolds:

Exercise 8.8. Given a Poisson manifold (M, π) , show that an immersed submanifold $N \hookrightarrow M$ is a Poisson submanifold if and only if, for any symplectic leaf S of M , $S \cap N$ is open in S and, for the smooth structure on $S \cap N$ induced from S , the inclusion $S \cap N \hookrightarrow N$ is smooth.

(HINT: Use a splitting chart and Proposition 8.2.)

The exercise also suggests considering the following class of Poisson submanifolds.

Definition 8.9. A Poisson submanifold $N \subset (M, \pi)$ is called **complete** if it is a union of symplectic leaves.

Exercise 8.10. Show that a submanifold $N \subset (M, \pi)$ is a complete Poisson submanifold if and only if any integral curve $\gamma : [0, 1] \rightarrow M$ of a Hamiltonian vector field that starts in N stays in N and is smooth as a curve in N .

Example 8.11 (Symplectic leaves). Obviously, any symplectic leaf is a Poisson submanifold. By definition, symplectic leaves are precisely the minimal complete Poisson submanifolds. 

Example 8.12 (Zeros). When $N = \{x\}$ consists of a single point, then N is a Poisson submanifold if and only if x is a zero of π . In general, any submanifold contained in the zero-locus of a Poisson bivector is a complete Poisson submanifold. 

Example 8.13 (Symplectic manifolds). By Proposition 8.2(i), the only Poisson submanifolds of a symplectic manifold are the open subsets. The complete Poisson submanifolds are the connected components. 

Example 8.14 (Log-symplectic manifolds). For a log-symplectic manifold (M, π) with singular locus Z , both $M \setminus Z$ and Z are (generally disconnected) complete Poisson submanifolds. They are both regular Poisson manifolds, but note that $M = (M \setminus Z) \cup Z$ is not a regular Poisson manifold. 

Example 8.15 (Degeneracy submanifolds). Generalizing the previous examples, given a Poisson manifold (M, π) , one can consider the set of points where π has rank at most $2k$:

$$Z_k := \{x \in M : \pi_x^{k+1} = 0\}.$$

If Z_k is an embedded submanifold, then it is a closed, complete Poisson submanifold. In fact, it is the union of all symplectic leaves of dimension

at most $2k$. Note that the $M \setminus Z_k$ are always open Poisson submanifolds. More generally, if the sets $Z_{k+l} \setminus Z_k$ are embedded submanifolds, then they are Poisson submanifolds. 

Example 8.16 (Ideals in Lie algebras). Let \mathfrak{g} be a Lie algebra and consider the linear Poisson structure $(\mathfrak{g}^*, \pi_{\mathfrak{g}})$. If $\mathfrak{h} \subset \mathfrak{g}$ is a linear subspace, then $\mathfrak{h}^\circ \subset \mathfrak{g}^*$ is a Poisson submanifold if and only if $\mathfrak{h} \subset \mathfrak{g}$ is a Lie ideal. One way to see this is by computing the orthogonals appearing in (ii) of Proposition 8.2; i.e., for $\xi \in \mathfrak{h}^\circ$,

$$(8.2) \quad \begin{aligned} (T_\xi \mathfrak{h}^\circ)^{\perp \pi_{\mathfrak{g}}} &= \{\pi_\xi^\#(u) : u \in (\mathfrak{g}^*)^* \text{ vanishing on } \mathfrak{h}^\circ\} \\ &= \{\text{ad}_u^*(\xi) : u \in \mathfrak{h}\} \subset \mathfrak{g}^*. \end{aligned}$$

Hence, the Poisson submanifold condition holds if and only if $\xi([\mathfrak{h}, \mathfrak{g}]) = 0$ for all $\xi \in \mathfrak{h}^\circ$; in other words, \mathfrak{h} is an ideal in \mathfrak{g} :

$$[\mathfrak{h}, \mathfrak{g}] \subset \mathfrak{h}.$$

Since \mathfrak{h}° is a union of symplectic leaves, it is a complete Poisson submanifold. Moreover, under the canonical isomorphism $\mathfrak{h}^\circ \simeq (\mathfrak{g}/\mathfrak{h})^*$, the induced Poisson structure on \mathfrak{h}° coincides the linear Poisson structure $\pi_{\mathfrak{g}/\mathfrak{h}}$. 

Example 8.17 (Level sets of Casimirs). Note that a smooth family of Poisson structures $\{\pi_t\}_{t \in I}$ on a manifold M is the same thing as a Poisson structure $\tilde{\pi}$ on $M \times I$ for which all the submanifolds $M \times \{t\}$ are Poisson submanifolds.

A closely related appearance of Poisson submanifolds is as level sets of a Casimir function C on an arbitrary Poisson manifold (M, π) . If $r \in \mathbb{R}$ is a regular value of C , it follows that the level set $\{C = r\}$ is automatically a complete Poisson submanifold of (M, π) . The Casimir relevant for a family on $M \times I$ is, of course, $C(x, t) = t$. 

Example 8.18 (Affine Poisson structures). Note that any affine Poisson manifold can be realized as a Poisson submanifold of a linear one. Indeed, given any 2-cocycle λ on a Lie algebra \mathfrak{g} , the inclusion

$$(\mathfrak{g}^*, \pi_{\mathfrak{g}, \lambda}) \hookrightarrow (\tilde{\mathfrak{g}}_\lambda^*, \pi_{\tilde{\mathfrak{g}}_\lambda}), \quad \xi \mapsto (\xi, 1)$$

realizes the affine Poisson structure $\pi_{\mathfrak{g}, \lambda}$ as a complete Poisson submanifold in the dual of the central extension $\tilde{\mathfrak{g}}_\lambda = \mathfrak{g} \oplus \mathbb{R}$. As seen in Subsection 2.4.8, this is a special case of the previous example. 

Example 8.19 (LV-type Poisson structures). For a Lotka-Volterra-type Poisson structure π_A on \mathbb{R}^n associated with a skew-symmetric matrix $A = (a^{ij})$ we find

$$\pi_A^\#(dx^i) = \sum_{j=1}^n a^{ij} x^i x^j \frac{\partial}{\partial x^j}.$$

It follows that for any integers $1 \leq i_1 < \dots < i_k \leq n$, the subspaces

$$V_{i_1, \dots, i_k} = \{(x^1, \dots, x^n) \in \mathbb{R}^n : x^{i_l} = 0, l = 1, \dots, k\}$$

are complete Poisson submanifolds. The induced Poisson bracket is the LV-type Poisson structure π_M associated with the $(n - k) \times (n - k)$ minor M of A obtained by removing the rows and columns i_1, \dots, i_k . 

Example 8.20 (Spheres in the dual of a compact Lie algebra). A Lie algebra is said to be **compact** if there exists some compact Lie group G with Lie algebra \mathfrak{g} . This can also be characterized by the existence of an inner product (\cdot, \cdot) which is ad-invariant:

$$([u, v], w) + (v, [u, w]) = 0, \quad \forall u, v, w \in \mathfrak{g}.$$

The induced inner product on \mathfrak{g}^* is invariant under the coadjoint action. Therefore, each sphere

$$\mathbb{S}_r = \{\xi \in \mathfrak{g}^* : \|\xi\| = r\}, \quad r > 0,$$

is a union of coadjoint orbits, i.e., of symplectic leaves for the linear Poisson structure, and so it is a complete Poisson submanifold. Of course, this fits in Example 8.17 for the Casimir function $C(\xi) := \|\xi\|^2$. 

Example 8.21 (Quotients and Hamiltonian actions). Consider a proper and free Hamiltonian G -space (M, π) with moment map $\mu : M \rightarrow \mathfrak{g}^*$, as in Section 1.5. For the quotient Poisson structure $(M/G, \pi_{M/G})$ we show that the submanifolds

$$M //_{\mathcal{O}} G := \mu^{-1}(\mathcal{O})/G \subset M/G$$

are Poisson submanifolds for any coadjoint orbit $\mathcal{O} \subset \mathfrak{g}^*$.

For any $H \in C^\infty(M/G)$, using that $H \circ p$ is G -invariant and the moment map condition (1.25), we find

$$0 = \omega(v)(H \circ p) = X_{\mu v}(H \circ p) = -X_{H \circ p}(\mu v), \quad \forall v \in \mathfrak{g}.$$

So $X_{H \circ p}$ is tangent to the μ -fibers and in particular to $\mu^{-1}(\mathcal{O})$. Therefore, $X_H = p_* X_{H \circ p}$ is tangent to $M //_{\mathcal{O}} G$, and so $M //_{\mathcal{O}} G \subset M/G$ is a Poisson submanifold. 

For Poisson transversals $X \subset (M, \pi)$ we have seen that any symplectic realization $\mu : (S, \omega) \rightarrow (M, \pi)$ restricts to a symplectic realization of X . More generally, we have seen that Poisson transversals behave functorially with respect to Poisson maps. The situation for Poisson submanifolds is more subtle. First of all, there is no functoriality: given a Poisson map $\Phi : (M_1, \pi_1) \rightarrow (M_2, \pi_2)$ and a Poisson submanifold $N \subset M_2$, *it is not true* that $\Phi^{-1}(N) \subset M_1$ is a Poisson submanifold, even if Φ is transverse to N . However, when it comes to symplectic realizations, the following result

shows that in many cases a symplectic realization of (M, π) can be used to obtain a realization of a Poisson submanifold N .

Proposition 8.22. *Let N be a Poisson submanifold of (M, π) , and consider a symplectic realization*

$$\mu : (S, \omega) \rightarrow (M, \pi).$$

Setting $C := \mu^{-1}(N)$ and $\omega_C := \omega|_C \in \Omega^2(C)$, we have the following:

(i) *The kernel of ω_C ,*

$$\mathcal{K}_C := \text{Ker } \omega_C \subset TC,$$

defines a regular foliation on C .

(ii) *If this foliation is simple, then ω_C descends to a symplectic form $\underline{\omega}$ on the leaf space $\underline{C} := C/\mathcal{K}_C$, and μ descends to a symplectic realization of the Poisson submanifold (N, π_N) :*

$$\underline{\mu} : (\underline{C}, \underline{\omega}) \rightarrow (N, \pi_N).$$

This proposition will be best understood when discussing coisotropic submanifolds, and so the proof is deferred until then. See also Proposition C.17.

Exercise 8.23. For a Poisson structure of LV-type, consider the natural symplectic realization of type (6.6), given in Example 6.12. Show that for the Poisson submanifolds V_{i_1, \dots, i_k} discussed in Example 8.19 the construction above yields a symplectic realization of V_{i_1, \dots, i_k} which is again of the same type (6.6).

Example 8.24. Consider the Poisson submanifold $\mathfrak{h}^\circ \subset \mathfrak{g}^*$ associated to a Lie ideal $\mathfrak{h} \subset \mathfrak{g}$ — see Example 8.16. Let G be a connected Lie group with Lie algebra \mathfrak{g} . Let $H \subset G$ be the connected Lie subgroup with Lie algebra \mathfrak{h} . Then H is normal; assume it is also closed. This assumption holds, e.g., if G is simply connected. Since \mathfrak{h} is an ideal, $\mathfrak{k} := \mathfrak{g}/\mathfrak{h}$ is the Lie algebra of $K := G/H$. Moreover, under the canonical identification $\mathfrak{h}^\circ \simeq \mathfrak{k}^*$ the Poisson structure on \mathfrak{h}° becomes the linear Poisson structure $\pi_{\mathfrak{k}}$.

We apply the proposition to the canonical symplectic realization (6.16)

$$\mu_G : (T^*G \simeq G \times \mathfrak{g}^*, \omega_{\text{can}}) \rightarrow (\mathfrak{g}^*, \pi_{\mathfrak{g}}).$$

Then

$$C = \mu_G^{-1}(\mathfrak{k}^*) = G \times \mathfrak{k}^*$$

and one can show that the kernel of $\omega_C = \omega_{\text{can}}|_C$ is made of the tangent spaces of the cosets of H in G . Therefore the resulting foliation is simple, with leaf space $G/H \times \mathfrak{k}^* = K \times \mathfrak{k}^*$. The resulting symplectic realization of $(\mathfrak{k}^*, \pi_{\mathfrak{k}})$ is precisely the canonical one corresponding to K

$$\mu_K : (T^*K \simeq K \times \mathfrak{k}^*, \omega_{\text{can}}) \rightarrow (\mathfrak{k}^*, \pi_{\mathfrak{k}}).$$

Let us remark that the identification of the symplectic manifolds $C/H \simeq T^*K$ can also be understood using Hamiltonian reduction

$$T^*(G/H) \simeq \mu_H^{-1}(0)/H = T^*G//H,$$

where $\mu_H : T^*G \rightarrow \mathfrak{h}^*$ is the composition of μ_G with the restriction map $\mathfrak{g}^* \rightarrow \mathfrak{h}^*$. The isomorphism is a particular case of Example B.21.

Exercise 8.25. Explain the relationship between the assumption that H is closed and the assumption made in item (ii) of Proposition 8.22. 

Exercise 8.26. Show that the symplectic realization of an affine Poisson structure constructed in Example 6.25 can be obtained from Proposition 8.22 applied to the Poisson submanifold from Example 8.18.

In the previous examples Proposition 8.22 could be applied to produce symplectic realizations. However, this is not always the case.

Example 8.27. For a compact Lie algebra \mathfrak{g} , consider a sphere $\mathbb{S}_r \subset \mathfrak{g}^*$ as in Example 8.20. Let G be a compact connected Lie group integrating \mathfrak{g} . For the canonical symplectic realization from (6.16),

$$\mu : (T^*G \simeq G \times \mathfrak{g}^*, \omega_{\text{can}}) \rightarrow (\mathfrak{g}^*, \pi_{\mathfrak{g}}),$$

we have

$$C = \mu^{-1}(\mathbb{S}_r) = G \times \mathbb{S}_r.$$

We claim that, in general, the kernel of $\omega_C = \omega_{\text{can}}|_C$ does not define a simple foliation, so Proposition 8.22 does not provide a symplectic realization of \mathbb{S}_r .

For this, recall from Example B.21 that the action of G on the right on itself lifts to a Hamiltonian action on T^*G with moment map μ . Under the identification $T^*G \simeq G \times \mathfrak{g}^*$, this action is given by

$$g \cdot (h, \xi) = (hg^{-1}, \text{Ad}_g^* \xi).$$

The moment map condition gives

$$i_{\mathfrak{a}(v)}\omega_{\text{can}} = d\mu_v.$$

The right-hand side is the differential of the map $(g, \xi) \mapsto \xi(v)$, so we obtain

$$d\mu_v|_{T_g G \times T_\xi \mathbb{S}_r} = 0 \iff v \in \text{Span}\{v_\xi\},$$

where $v_\xi \in \mathfrak{g}$ is the element corresponding to ξ under the isomorphism $\mathfrak{g} \simeq \mathfrak{g}^*$ induced by the inner product. Since $\text{Ker } \omega_C$ is 1-dimensional, we obtain

$$\text{Ker } \omega_C|_{(g, \xi)} = \text{Span}\{\mathfrak{a}(v_\xi)|_{(g, \xi)}\}.$$

Next, using that $\text{ad}_{v_\xi}^* \xi = 0$, it follows that the leaf through (g, ξ) of the foliation of $G \times \mathbb{S}_r$ defined by $\text{Ker } \omega_C$ is

$$L_{(g, \xi)} = \{(g \exp(tv_\xi), \xi) : t \in \mathbb{R}\}.$$

Exercise 8.28. Show the following:

- (a) If $\mathfrak{g} = \mathfrak{so}(3)$, the resulting foliation of $C = \mathrm{SO}(3) \times \mathbb{S}^2$ is simple.
 (b) If $\mathfrak{g} = \mathfrak{so}(4)$, the resulting foliation of $C = \mathrm{SO}(4) \times \mathbb{S}^5$ is not simple.
 (HINT: $\mathfrak{so}(4) \simeq \mathfrak{so}(3) \oplus \mathfrak{so}(3)$). 

8.2. Poisson-Dirac submanifolds

Poisson submanifolds and Poisson transversals are two types of submanifolds which naturally inherit Poisson structures. Dirac geometry offers a general framework to deal with such submanifolds.

Definition 8.29. A **Poisson-Dirac submanifold** of a Poisson manifold (M, π) is a Poisson manifold (N, π_N) with an injective immersion

$$i : (N, L_{\pi_N}) \hookrightarrow (M, L_{\pi})$$

which is a backward Dirac map.

Note that given a submanifold N of a Poisson manifold (M, π) there is at most one Poisson structure on N making the inclusion a Poisson-Dirac submanifold. On the other hand, the existence of this structure can be characterized as follows:

Proposition 8.30. *An immersed submanifold $i : N \hookrightarrow M$ of a Poisson manifold (M, π) is a Poisson-Dirac submanifold if and only if the following conditions hold:*

- (i) $T_x N \cap (T_x N)^{\perp \pi} = 0$, for all $x \in N$.
 (ii) The bivector field $\pi_N \in \Gamma(\wedge^2 TN)$ defined at each point by
- $$(8.3) \quad \pi_{N,x}(\xi, \eta) = \pi_x(\tilde{\xi}, \tilde{\eta}) \quad (\xi, \eta \in T_x^* N),$$
- where $\tilde{\xi}, \tilde{\eta} \in ((T_x N)^{\perp \pi})^\circ$ are extensions of ξ, η , is smooth.

The extensions in item (ii) exist by item (i). Moreover, the proposition says that (i) and (ii) imply that $\pi_N \in \mathfrak{X}^2(N)$ is automatically a Poisson structure. On the other hand, the following exercise shows that the smoothness condition (ii) is not automatic.

Exercise 8.31. Consider the regular foliation of \mathbb{C}^3 by complex lines

$$z_2 = a, \quad z_3 = az_1 + b \quad (a, b \in \mathbb{C}).$$

The leaves are symplectic submanifolds of $(\mathbb{C}^3 \simeq \mathbb{R}^6, \omega_{\mathrm{can}})$. They form the symplectic foliation of a regular Poisson structure π on $M = \mathbb{R}^6$. Show that the 4-dimensional submanifold $N = \{(z_1, z_2, z_3) : z_3 = 0\} \subset M$ satisfies condition (i) of Proposition 8.30 but does not satisfy condition (ii). 

Proof of Proposition 8.30. The proposition will follow by spelling out Definition 8.29. Consider a submanifold N of a Poisson manifold (M, π) . We claim that for each $x \in N$, the pullback Dirac structure

$$(i^! \mathbb{L}_\pi)_x \in \mathfrak{D}(T_x N)$$

comes from a bivector $\pi_{N,x} \in \bigwedge^2 T_x N$ if and only if condition (i) in the previous proposition holds. Indeed using the definition of $(i^! \mathbb{L}_\pi)_x$ we find

$$\begin{aligned} (i^! \mathbb{L}_\pi)_x &= \{w + \tilde{\xi}|_{T_x N} \in \mathbb{T}_x N : \tilde{\xi} \in T_x^* M \text{ and } w = \pi^\sharp \tilde{\xi}\} \\ &= \{\pi^\sharp \tilde{\xi} + \tilde{\xi}|_{T_x N} \in \mathbb{T}_x N : \tilde{\xi} \in T_x^* M \text{ such that } \pi^\sharp \tilde{\xi} \in T_x N\}. \end{aligned}$$

Lemma 7.6 shows that this subspace comes from a bivector if and only if

$$\begin{aligned} (i^! \mathbb{L}_\pi)_x \cap T_x N &= \{\pi^\sharp \tilde{\xi} : \tilde{\xi} \in T_x^* M \text{ with } \tilde{\xi}|_{T_x N} = 0, \pi^\sharp \tilde{\xi} \in T_x N\} \\ &= T_x N \cap (T_x N)^{\perp \pi} = \{0\}. \end{aligned}$$

This proves the claim.

Now if (i) holds, the bivector $\pi_{N,x} \in \bigwedge^2 T_x N$ inducing $(i^! \mathbb{L}_\pi)_x$ is precisely the bivector field described by the explicit formula (8.3). Theorem 7.32 implies that \mathbb{L}_{π_N} is a Dirac structure, and so π_N is a Poisson structure. \square

Example 8.32 (Poisson submanifolds and transversals). It follows immediately from Proposition 8.30 that Poisson submanifolds $((T_x N)^{\perp \pi} = \{0\})$ and Poisson transversals $(T_x M = T_x N \oplus (T_x N)^{\perp \pi})$ are particular classes of Poisson-Dirac submanifolds. For a Poisson transversal we already knew that the inclusion is a backward Dirac map — see Example 7.34. On other hand, for a Poisson submanifold the inclusion is both a forward and a backward Dirac map.

A Poisson transversal of (M, π) intersects each symplectic leaf transversely. In the following exercise you are asked to show that this property distinguishes Poisson transversals among all Poisson-Dirac submanifolds.

Exercise 8.33. Show that a Poisson-Dirac submanifold N of (M, π) is a Poisson transversal iff it is transverse to each symplectic leaf of π , i.e., iff

$$T_x M = T_x N + \text{Im } \pi_x^\sharp, \quad \forall x \in N. \quad \text{🐟}$$

Example 8.34 (Singletons). Submanifolds consisting of one point are automatically Poisson-Dirac submanifolds. They are Poisson transversals if and only if the Poisson structure is nondegenerate at the point and they are Poisson submanifolds if and only if the Poisson structure vanishes at the point. 🐟

Example 8.35 (Symplectic submanifolds). For a symplectic manifold (M, ω) , the Poisson-Dirac submanifolds are precisely the symplectic submanifolds of (M, ω) , and so they coincide with the Poisson transversals of (M, ω) . 🐟

Example 8.36 (Linear Poisson structures). Let \mathfrak{g} be a Lie algebra and consider the linear Poisson structure $(\mathfrak{g}^*, \pi_{\mathfrak{g}})$. A sufficient condition for a linear space $\mathfrak{h}^\circ \subset \mathfrak{g}^*$ to be a Poisson-Dirac submanifold can be obtained from (8.2):

$$(T_\xi \mathfrak{h}^\circ)^{\perp \pi_{\mathfrak{g}}} = \{\text{ad}_u^*(\xi) : u \in \mathfrak{h}\} \subset \mathfrak{g}^*.$$

Hence, the first condition in Proposition 8.30 is satisfied if and only if for every $\xi \in \mathfrak{h}^\circ$ and $u \in \mathfrak{h}$ one has

$$\langle \xi, [u, u'] \rangle = 0, \forall u' \in \mathfrak{h} \implies \langle \xi, [u, v] \rangle = 0, \forall v \in \mathfrak{g}.$$

For example, this holds if $\mathfrak{h} \subset \mathfrak{g}$ admits a complement $\mathfrak{k} \subset \mathfrak{g}$ such that

$$(8.4) \quad \mathfrak{g} = \mathfrak{h} \oplus \mathfrak{k}, \quad [\mathfrak{h}, \mathfrak{k}] \subset \mathfrak{h}.$$

This should be compared with the condition found in Example 8.16 for \mathfrak{h}° to be a Poisson submanifold, namely that \mathfrak{h} is an ideal in \mathfrak{g} .

One still needs to check that condition (ii) in Proposition 8.30 holds. We claim that the existence of a complement (8.4) is also enough for (ii) to hold true. In fact, if such complement exists, then $(T_\xi \mathfrak{h}^\circ)^{\perp \pi_{\mathfrak{g}}} \subset \mathfrak{k}^\circ$, and so

$$T_\xi^* \mathfrak{h}^\circ \simeq \mathfrak{k} \subset ((T_\xi \mathfrak{h}^\circ)^{\perp \pi_{\mathfrak{g}}})^\circ.$$

Hence, given an $\eta \in T_\xi^* \mathfrak{h}^\circ$, if we view it as a constant form in \mathfrak{k} , we have an extension $\tilde{\eta} \in ((T \mathfrak{h}^\circ)^{\perp \pi})^\circ$, and it follows that condition (ii) holds.

We conclude that the existence of a complement (8.4) is a sufficient condition for $\mathfrak{h}^\circ \subset \mathfrak{g}^*$ to be a Poisson-Dirac submanifold. We leave it as an exercise to show that the induced Poisson structure is linear.

For a simple concrete example, consider a compact Lie algebra \mathfrak{g} with an invariant inner product (\cdot, \cdot) . Let $\mathfrak{k} \subset \mathfrak{g}$ be a subalgebra, and let $\mathfrak{h} = \mathfrak{k}^\perp$. Then the invariance of the inner product gives

$$([u, v], v') = (u, [v, v']) = 0, \quad \forall u \in \mathfrak{h}, v, v' \in \mathfrak{k}.$$

So $[\mathfrak{h}, \mathfrak{k}] \subset \mathfrak{h}$ holds and we conclude that $\mathfrak{h}^\circ \subset \mathfrak{g}^*$ is a Poisson-Dirac submanifold. Via the isomorphism $\mathfrak{h}^\circ \simeq \mathfrak{k}^*$, the induced Poisson structure is the linear one corresponding to \mathfrak{k} . Note that if \mathfrak{h} is not an ideal, then \mathfrak{h}° is neither a Poisson submanifold nor a Poisson transversal. 

Example 8.37. Given a Poisson manifold (N, π) one can try to embed it as a Poisson-Dirac submanifold of a simpler (e.g., linear) Poisson manifold.

For instance, consider $N = \mathbb{R}^2$ with Poisson bracket defined by $\{x, y\} = x^2 + y^2$. One can enlarge it by adding extra coordinates z, w , and c (c indicating that this coordinate will be a Casimir) and embed it into a linear Poisson structure in $M = \mathbb{R}^5$: relative to the coordinates (x, y, z, w, c) the

linear Poisson bracket is defined by

$$\begin{aligned}\{x, y\} &= 0, & \{x, z\} &= x, & \{x, w\} &= y, \\ \{y, z\} &= y, & \{y, w\} &= -x, & \{z, w\} &= c, \\ \{x, c\} &= \{y, c\} = \{z, c\} = \{w, c\} &= 0.\end{aligned}$$

We leave it as an exercise to check that the embedding $N \hookrightarrow M$, $(x, y) \mapsto (x, y, 0, 0, 1)$ turns N into a Poisson-Dirac submanifold of M and that the induced Poisson structure is precisely $\{x, y\} = x^2 + y^2$. 

In general, the relationship between the symplectic foliations of a Poisson-Dirac submanifold and of the ambient Poisson manifold is subtle. This was already observed in Remark 7.35 for pullbacks of Dirac structures and the following example illustrates it in the case of Poisson structures.

Example 8.38. Consider $M = \mathbb{R}^4$ with coordinates (u, v, z, w) and the log-symplectic Poisson structure

$$\pi = u \frac{\partial}{\partial u} \wedge \frac{\partial}{\partial v} + \frac{\partial}{\partial z} \wedge \frac{\partial}{\partial w}.$$

The injective immersion

$$i : \mathbb{R}^2 \rightarrow \mathbb{R}^4, \quad (x, y) \mapsto (x^2, 0, x, y)$$

gives a Poisson-Dirac submanifold $N \subset M$ with Poisson bivector field

$$\pi_N = \frac{\partial}{\partial x} \wedge \frac{\partial}{\partial y}.$$

The Poisson manifold (N, π_N) is nondegenerate, so it has only one leaf, but it intersects three different symplectic leaves of (M, π) . 

Example 8.39. Consider an LV-type Poisson structure on $M = \mathbb{R}^4$:

$$\begin{aligned}\{x, y\} &= xy, & \{x, z\} &= 0, & \{x, w\} &= xw, \\ \{z, y\} &= zy, & \{y, w\} &= 0, & \{z, w\} &= zw.\end{aligned}$$

We leave it as an exercise to check that the embedding $\mathbb{R}^2 \hookrightarrow \mathbb{R}^4$, $(u, v) \mapsto (u, v, u, v)$ gives a Poisson-Dirac submanifold and that the induced Poisson structure on \mathbb{R}^2 is again of Lotka-Volterra-type:

$$\{u, v\} = uv.$$

This is neither a Poisson submanifold nor a Poisson transversal. It is instructive to compare the resulting symplectic foliations of \mathbb{R}^2 and \mathbb{R}^4 . 

8.3. Coregular Poisson-Dirac submanifolds

It turns out that among Poisson-Dirac submanifolds there is a particularly well-behaved class.

Definition 8.40. A **coregular Poisson-Dirac submanifold** is a submanifold N of a Poisson manifold (M, π) such that

- (i) $TN \cap (TN)^{\perp\pi} = \{0\}$,
- (ii) $TN^{\perp\pi}$ has constant rank.

Exercise 8.41. If N is a submanifold of a Poisson manifold (M, π) for which the π -orthogonals $(T_x N)^{\perp\pi}$ have constant rank, show that $(TN)^{\perp\pi} \subset T_N M$ is a smooth subbundle.

Next we show that these submanifolds are indeed Poisson-Dirac and, moreover, that unlike general Poisson-Dirac submanifolds, their symplectic foliation has a simple description.

Proposition 8.42. *Let (M, π) be a Poisson manifold, and let $N \subset M$ be a submanifold with the property that $(TN)^{\perp\pi}$ has constant rank. Then N is a Poisson-Dirac submanifold if and only if $TN \cap (TN)^{\perp\pi} = 0$.*

In this case, the symplectic leaves of (N, π_N) are the connected components of the intersections $(N \cap S, \omega_S|_{N \cap S})$, where (S, ω_S) ranges over the symplectic leaves of (M, π) .

Proof. Applying Theorem 7.33 to the Dirac structure associated with the Poisson manifold (M, π) , we conclude that if $T_x N + \text{Im } \pi_x^\sharp$ is of constant dimension, then $i^! \mathbb{L}_\pi$ is a Dirac structure on N . Since

$$\begin{aligned} \dim(T_x N + \text{Im } \pi_x^\sharp) &= \dim N + \dim(\text{Im } \pi_x^\sharp) - \dim(T_x N \cap \text{Im } \pi_x^\sharp) \\ &= \dim N + \dim(T_x N)^{\perp\pi}, \end{aligned}$$

the assumption in the corollary guarantees that $i^! \mathbb{L}_\pi$ is a Dirac structure. This Dirac structure is the graph of a Poisson bivector field if and only if $TN \cap (TN)^{\perp\pi} = 0$, and then Theorem 7.33 gives the description of the symplectic leaves of (N, π_N) , so the proposition follows. \square

Exercise 8.43. Show that the constant rank condition (ii) in Definition 8.40 does not hold for the Poisson-Dirac submanifolds from Examples 8.38 and 8.39.

Before we give examples of coregular Poisson-Dirac submanifolds, we provide some more geometric insight into this special class of submanifolds.

Theorem 8.44. *Given an embedded submanifold N of a Poisson manifold (M, π) , the following are equivalent:*

- (i) N is a coregular Poisson-Dirac submanifold.
- (ii) N is a Poisson submanifold inside a Poisson transversal $X \subset M$.

Moreover, in this case the germ of X around N is unique up to local Poisson diffeomorphisms.

Proof. (i) \Rightarrow (ii). Let N be a Poisson-Dirac submanifold of (M, π) , and assume that $(TN)^\perp_\pi$ has constant rank. Since $TN \cap (TN)^\perp_\pi = \{0\}$, we can choose a vector subbundle $TN \subset V \subset T_N M$ satisfying

$$V \oplus (TN)^\perp_\pi = T_N M.$$

We claim that $V^\perp_\pi = (TN)^\perp_\pi$, so that

$$V \oplus V^\perp_\pi = T_N M.$$

Hence, if we choose a small enough submanifold $N \subset X \subset M$ with $T_N X = V$ — which can be done because N is embedded — then X will be a Poisson transversal in M and N a Poisson submanifold of X , so (ii) follows.

To prove the claim, observe that

$$((TN)^\perp_\pi)^\circ = \{\alpha \in T_N^* M : \pi^\sharp(\alpha) \in TN\} \supset \text{Ker } \pi^\sharp|_N.$$

So $\text{Ker } \pi^\sharp \cap V^\circ = \{0\}$ and we conclude that $V^\perp_\pi := \pi^\sharp(V^\circ)$ has dimension complementary to V : $\dim V^\perp_\pi = \dim(TN)^\perp_\pi$. However, since $TN \subset V$ we also have $V^\perp_\pi \subset (TN)^\perp_\pi$, so we must have $V^\perp_\pi = (TN)^\perp_\pi$ as claimed.

(ii) \Rightarrow (i). Assume that there exists a Poisson transversal $X \supset N$ of (M, π) such that N is a Poisson submanifold of X . In particular, N is a Poisson-Dirac submanifold. We claim that $(T_N X)^\perp_\pi = (TN)^\perp_\pi$, so $(TN)^\perp_\pi$ has constant rank.

To prove the claim observe that $T_N X \supset TN$ so $(T_N X)^\perp_\pi \subset (TN)^\perp_\pi$. To prove the reverse inclusion we show that $((T_N X)^\perp_\pi)^\circ \subset ((TN)^\perp_\pi)^\circ$. By the definition of \perp_π , we have

$$\begin{aligned} ((TN)^\perp_\pi)^\circ &= \{\alpha \in T_N^* M : \pi^\sharp(\alpha) \in TN\}, \\ ((T_N X)^\perp_\pi)^\circ &= \{\alpha \in T_N^* M : \pi^\sharp(\alpha) \in T_N X\}. \end{aligned}$$

Since X is a Poisson transversal, if $\pi^\sharp(\alpha) \in T_N X$, then $\pi^\sharp(\alpha) = \pi^\sharp_X(\alpha|_{T_N X})$; since N is a Poisson submanifold of (X, π_X) , we obtain that $\pi^\sharp(\alpha) \in TN$. This proves that $((T_N X)^\perp_\pi)^\circ \subset ((TN)^\perp_\pi)^\circ$.

The proof of uniqueness of the germ of X around N is left as an exercise — see Problem 8.13. □

Example 8.45. Consider a singleton $\{x\}$ viewed as a Poisson-Dirac submanifold, as in Example 8.34. The Poisson transversal given by the proposition is precisely a slice to the symplectic leaf through x . Hence, one recovers slices and *the* transverse Poisson structure of Theorem 5.19. 

Example 8.46. Poisson submanifolds and Poisson transversals are examples of coregular Poisson-Dirac submanifolds. The proposition shows that Poisson submanifolds of Poisson transversals are coregular Poisson-Dirac, and in fact, they all arise in this way. 

Example 8.47. Let us consider again Example 8.37, where $N = \mathbb{R}^2$ is a Poisson-Dirac submanifold of $M = \mathbb{R}^5$. We find that

$$(TN)_{(x,y,0,0,1)}^{\perp\pi} = \text{Span} \left\{ x \frac{\partial}{\partial x} + y \frac{\partial}{\partial y} - \frac{\partial}{\partial w}, y \frac{\partial}{\partial x} - x \frac{\partial}{\partial y} + \frac{\partial}{\partial z} \right\},$$

so it has constant rank. Then Theorem 8.44 gives a Poisson transversal $N \subset X \subset M$, where $N \subset X$ becomes a Poisson submanifold. To find X we follow the proof of Theorem 8.44: we look for a vector subbundle $TN \subset V \subset T_N M$ satisfying

$$V_x \oplus (TN)_x^{\perp\pi} = T_x M, \quad \forall x \in N.$$

A solution is

$$V_x = \text{Span} \left\{ \frac{\partial}{\partial x}, \frac{\partial}{\partial y}, \frac{\partial}{\partial c} \right\}, \quad \forall x \in N,$$

so we can take $X \supset N$ to be open in the linear subspace $z = w = 0$. For example, if we let

$$X = \{(x, y, 0, 0, c) : x, y, c \in \mathbb{R}, c > 0\},$$

one checks that it is a Poisson transversal. The resulting Poisson structure on X is given by

$$\{x, y\} = \frac{x^2 + y^2}{c}, \quad \{x, c\} = \{y, c\} = 0.$$

Each slice $c = c_0$ is a Poisson submanifold and at $c = 1$ one recovers N .

Exercise 8.48. Show that $Q = \{(x, y, z, w, 1) : x, y, z, w \in \mathbb{R}\} \subset M$ is a Poisson submanifold and $N \subset Q$ is a Poisson transversal. Find the induced Poisson bracket on Q .

(HINT: Use that $(x, y, z, w, c) \mapsto c$ is a Casimir and that $(x, y, z, w, 1) \mapsto (z, w)$ can be made into a Poisson map $Q \rightarrow \mathbb{R}^2$.) 

Remark 8.49 (Symplectic realizations). The way that symplectic realizations interact with Poisson-Dirac submanifolds is subtle. However, in the case of coregular Poisson-Dirac submanifolds Proposition 8.22 generalizes word by word. Actually, the result for Poisson manifolds also implies the one for coregular Poisson-Dirac submanifolds. This follows using Theorem 8.44

to embed a coregular Poisson-Dirac submanifold into a Poisson transversal as a Poisson submanifold and then applying Proposition 6.2.

We will not discuss this further here because, similar to the case of Poisson submanifolds, this result becomes more natural within the general framework of pre-Poisson manifolds to be discussed in Section 8.6.

8.4. Coisotropic submanifolds

So far we have discussed various classes of submanifolds, namely symplectic leaves, Poisson submanifolds, Poisson transversals, Poisson-Dirac submanifolds, all having the important property that they carry induced Poisson structures. We now move to a different class of submanifolds which play an important role in reduction.

Definition 8.50. A **coisotropic** submanifold of a Poisson manifold (M, π) is any submanifold $C \subset M$ satisfying

$$(TC)^{\perp\pi} \subset TC.$$

There are two extreme instances of coisotropic submanifolds:

- (i) $(TC)^{\perp\pi} = 0$: these are exactly **Poisson submanifolds**.
- (ii) $(TC)^{\perp\pi} = TC \cap \text{Im } \pi^\sharp$: these are called **Lagrangian submanifolds**.

Example 8.51. For a symplectic manifold, one recovers the classical notion of coisotropic submanifold. For example, in \mathbb{R}^{2n} with the canonical Poisson structure the submanifold

$$C_r = \{(q, p) \in \mathbb{R}^{2n} : p_{n-r+1} = p_{n-r+2} = \cdots = p_n = 0\} \quad (1 \leq r \leq n)$$

is coisotropic, and it is Lagrangian iff $r = n$. 

Exercise 8.52. Let C be a submanifold of (M, π) which intersects the symplectic leaves cleanly. Show that C is coisotropic if and only if the intersection $C \cap S$ is a coisotropic submanifold of (S, ω_S) for each leaf S . Show that a similar result holds if coisotropic is replaced by Lagrangian.

Example 8.53. As in symplectic geometry, codimension-1 submanifolds of Poisson manifolds are automatically coisotropic. For example, if one considers the Poisson manifold \mathbb{R}^3 with symplectic foliation by planes $z = c$, then the parabola $z = y^2 + x^2$ will be a coisotropic submanifold for any foliated symplectic form. Note that the intersection with the leaf $z = 0$ is just a single point, hence it is not a coisotropic submanifold of the leaf. 

Example 8.54. Poisson submanifolds are precisely those submanifolds that are simultaneously coisotropic and Poisson-Dirac. 

The following result lists alternative characterizations of the coisotropic condition for *embedded* submanifolds. You should compare them with the similar characterizations for Poisson submanifolds from Proposition 8.2.

Proposition 8.55. *Let (M, π) be a Poisson manifold. For an embedded submanifold $C \subset M$ the following conditions are equivalent:*

- (i) C is a coisotropic submanifold.
- (ii) The set of 1-forms

$$\Omega_C^1(M) := \{\alpha \in \Omega^1(M) : \alpha|_{TC} = 0\}$$

is closed under the Lie bracket $[\cdot, \cdot]_\pi$.

- (iii) The vanishing ideal $\mathcal{I}(C)$ is a Lie subalgebra.
- (iv) X_H is tangent to C for any $H \in \mathcal{I}(C)$.

Proof. (i) \Rightarrow (ii). Let $\alpha, \beta \in \Omega_C^1(M)$. Recall that

$$[\alpha, \beta]_\pi = \mathcal{L}_{\pi^\sharp(\alpha)}(\beta) - \mathcal{L}_{\pi^\sharp(\beta)}(\alpha) - d\pi(\alpha, \beta).$$

Since $\pi^\sharp(\alpha)$ and $\pi^\sharp(\beta)$ are tangent to C , the first two terms are in $\Omega_C^1(M)$. The third belongs to $\Omega_C^1(M)$ because $\pi(\alpha, \beta)|_C = 0$.

- (ii) \Rightarrow (iii). Let $\alpha \in \Omega_C^1(M)$ and $g \in \mathcal{I}(C)$. For any $\beta \in \Omega^1(M)$,

$$[\alpha, g\beta]_\pi = (\mathcal{L}_{\pi^\sharp(\alpha)}g)\beta + g[\alpha, \beta]_\pi.$$

By assumption, the left-hand side is in $\Omega_C^1(M)$ and, since $g \in \mathcal{I}(C)$, so is the last term on the right-hand side. Thus $(\mathcal{L}_{\pi^\sharp(\alpha)}g)\beta \in \Omega_C^1(M)$. Since β is arbitrary, this implies that $\mathcal{L}_{\pi^\sharp(\alpha)}g \in \mathcal{I}(C)$. Letting $\alpha := df$, with $f \in \mathcal{I}(C)$, we obtain that $\{f, g\} \in \mathcal{I}(C)$.

- (iii) \Rightarrow (iv). For $H, f \in \mathcal{I}(C)$, we have

$$X_H(f)(x) = \{H, f\}(x) = 0, \quad \forall x \in C.$$

Since C is an embedded submanifold, this implies that X_H is tangent to C .

- (iv) \Rightarrow (i). For any $f, g \in \mathcal{I}(C)$, we have that

$$\pi(d_x f, d_x g) = X_f(g)(x) = 0, \quad \forall x \in C.$$

Since C is an embedded submanifold, we have that $(T_x C)^\circ$ is generated by elements $d_x f$ where $f \in \mathcal{I}(C)$. We conclude that

$$\pi(\alpha, \beta) = 0, \quad \forall \alpha, \beta \in (TC)^\circ.$$

This is equivalent to $(TC)^\perp \subset TC$. □

Example 8.56. The characterizations from Proposition 8.55 might fail for nonembedded submanifolds. For example, let $M = \mathbb{T}^3$ with the rank 2 Poisson structure $\pi = \frac{\partial}{\partial \varphi^1} \wedge \frac{\partial}{\partial \varphi^2}$, and let N be a line

$$i : \mathbb{R} \hookrightarrow \mathbb{T}^3, \quad t \mapsto (at, bt, t),$$

where $a, b, 1 \in \mathbb{R}$ are linearly independent over \mathbb{Q} . Then N is a Poisson transversal, so it is not coisotropic. On the other hand, since N is dense in \mathbb{T}^3 , the vanishing ideal $\mathcal{I}(N)$ consists only of the zero function, which is of course a Lie subalgebra. 

Example 8.57. For the linear Poisson structure in the dual of a Lie algebra $(\mathfrak{g}^*, \pi_{\mathfrak{g}})$ a linear subspace $\mathfrak{h}^\circ \subset \mathfrak{g}^*$ is a coisotropic submanifold if and only if $\mathfrak{h} \subset \mathfrak{g}$ is a Lie subalgebra. This follows from expression (8.2) for $(T\mathfrak{h}^\circ)^\perp_{\pi_{\mathfrak{g}}}$ in Example 8.16, where we saw that ideals correspond to linear Poisson submanifolds. 

Example 8.58. Given a Poisson manifold (M, π) and two commuting Poisson vector fields $X, Y \in \mathfrak{X}(M, \pi)$, we saw in Example 5.15 that for each $\lambda \in \mathbb{R} \setminus \{0\}$ the bivector field

$$\pi_\lambda := \pi + X \wedge \frac{\partial}{\partial t} + Y \wedge \frac{\partial}{\partial s} + \lambda \frac{\partial}{\partial t} \wedge \frac{\partial}{\partial s}$$

defines a Poisson structure on $M \times \mathbb{R}^2$ for which $M \times \{0\}$ is a Poisson transversal. When $\lambda = 0$, $M \times \{0\}$ becomes a coisotropic submanifold. Therefore, although Poisson transversals and coisotropic submanifolds are rather far apart, a small perturbation of π may deform a coisotropic submanifold into a Poisson transversal. 

Example 8.59. Generalizing the symplectic case, given a Hamiltonian action of a Lie group G on a Poisson manifold (M, π) with moment map $\mu : M \rightarrow \mathfrak{g}^*$ for which $0 \in \mathfrak{g}^*$ is a regular value, the zero level set $\mu^{-1}(0) \subset M$ is a coisotropic submanifold: its π -orthogonal coincides with the span of the infinitesimal generators of the action and since μ is G -equivariant these are tangent to $\mu^{-1}(0)$. 

Another important reason to consider coisotropic submanifolds is their close relationship with Poisson maps:

Theorem 8.60. *A smooth map $\Phi : M_1 \rightarrow M_2$ between two Poisson manifolds (M_1, π_1) and (M_2, π_2) is a Poisson map if and only if its graph,*

$$\text{Graph}(\Phi) = \{(x_1, \Phi(x_1)) : x_1 \in M_1\} \subset M_1 \times M_2,$$

is a coisotropic submanifold of $(M_1, \pi_1) \times (M_2, -\pi_2)$.

Proof. Notice that we have

$$T\text{Graph}(\Phi) = \{(v, d\Phi(v)) : v \in TM_1\},$$

so that

$$(T\text{Graph}(\Phi))^\circ = \{((d\Phi)^*\beta, -\beta) : \beta \in T^*M_2\}.$$

Let π denote the Poisson structure on $(M_1, \pi_1) \times (M_2, -\pi_2)$. It follows that

$$\begin{aligned} (T\text{Graph}(\Phi))^{\perp\pi} &= \pi^\sharp\left((T\text{Graph}(\Phi))^\circ\right) \\ &= \{(\pi_1^\sharp((d\Phi)^*\beta), \pi_2^\sharp(\beta)) : \beta \in T^*M_2\}. \end{aligned}$$

From this it is clear that $\text{Graph}(\Phi)$ is coisotropic; i.e.,

$$(T\text{Graph}(\Phi))^{\perp\pi} \subset T\text{Graph}(\Phi)$$

if and only if

$$d\Phi \circ \pi_1^\sharp \circ (d\Phi)^*\beta = \pi_2^\sharp(\beta), \quad \forall \beta \in T^*M_2,$$

which means that Φ is a Poisson map. □

Recall that, in general, the pullback of a Poisson submanifold by a Poisson map transverse to it is not a Poisson submanifold. Since a Poisson submanifold is an example of a coisotropic submanifold the situation is clarified by the following result.

Proposition 8.61. *Let $\Phi : (M, \pi_M) \rightarrow (N, \pi_N)$ be a Poisson map, and assume that Φ is transverse to a submanifold $C \subset N$. If $C \subset N$ is a coisotropic submanifold, then so is $\Phi^{-1}(C) \subset M$. The converse holds when $C \subset \Phi(M)$.*

Proof. Since Φ is transverse to C , $\Phi^{-1}(C) \subset M$ is a submanifold and for $x \in \Phi^{-1}(C)$ and $y = \Phi(x)$,

$$T_x\Phi^{-1}(C) = (d_x\Phi)^{-1}(T_yC), \quad (T_x\Phi^{-1}(C))^\circ = (d_x\Phi)^*(T_yC)^\circ.$$

Using that Φ is a Poisson map, we find that

$$\begin{aligned} d_x\Phi((T_x\Phi^{-1}(C))^{\perp\pi_M}) &= d_x\Phi \circ \pi_M^\sharp(T_x\Phi^{-1}(C))^\circ \\ &= d_x\Phi \circ \pi_M^\sharp \circ (d_x\Phi)^*(T_yC)^\circ \\ &= \pi_N^\sharp(T_yC)^\circ = (T_yC)^{\perp\pi_N}. \end{aligned}$$

Assume that $C \subset N$ is coisotropic. Then for all $x \in \Phi^{-1}(C)$

$$(T_x\Phi^{-1}(C))^{\perp\pi_M} \subset (d_x\Phi)^{-1}((T_yC)^{\perp\pi_N}) \subset (d_x\Phi)^{-1}(T_yC) = T_x\Phi^{-1}(C),$$

where $y = \Phi(x)$. So $\Phi^{-1}(C)$ is a coisotropic submanifold.

Conversely, assume that $\Phi^{-1}(C)$ is a coisotropic submanifold and in addition that $C \subset \Phi(M)$. Then, for each $y \in C$ we find $x \in \Phi^{-1}(y)$, and so

$$(T_yC)^{\perp\pi_N} = d_x\Phi((T_x\Phi^{-1}(C))^{\perp\pi_M}) \subset d_x\Phi(T_x\Phi^{-1}(C)) \subset T_yC.$$

So C is a coisotropic submanifold. □

Example 8.62. For a proper and free Poisson action of a Lie group G on a Poisson manifold (M, π) , the map $p : M \rightarrow M/G$ is a Poisson submersion. Hence, the proposition shows that a G -invariant submanifold $C \subset M$ is coisotropic if and only if $C/G \subset M/G$ is coisotropic. 

Example 8.63. Since the coadjoint orbit $\mathcal{O}_\xi \subset \mathfrak{g}^*$ is a Poisson submanifold it is also a coisotropic submanifold. Hence, if ξ is a regular value of the moment map $\mu : (M, \pi) \rightarrow \mathfrak{g}^*$, for some G -Hamiltonian action, then $\mu^{-1}(\mathcal{O}_\xi) \subset M$ is a coisotropic submanifold. In particular, this recovers Example 8.59. 

As we have mentioned before, in general, a coisotropic submanifold C does not inherit a Poisson structure from the ambient Poisson manifold (M, π) . However, the fact that $\mathcal{I}(C) \subset C^\infty(M)$ is a Poisson algebra suggests the existence of some Poisson structure associated with C . For this we introduce:

Definition 8.64. The **characteristic distribution** of a coisotropic submanifold C of a Poisson manifold (M, π) is

$$\mathcal{K}_C := (TC)^\perp \subset TC.$$

Theorem 8.65 (Coisotropic reduction). *Let C be a coisotropic submanifold of (M, π) , and assume that \mathcal{K}_C has constant rank. Then:*

- (i) \mathcal{K}_C defines a regular foliation, called the **characteristic foliation**.
- (ii) If this foliation is simple, then its leaf space $\underline{C} := C/\mathcal{K}_C$ carries a unique Poisson structure $\underline{\pi} \in \mathfrak{X}^2(\underline{C})$ satisfying

$$p^! \mathbb{L}_{\underline{\pi}} = i^! \mathbb{L}_\pi,$$

where $i : C \hookrightarrow M$ is the inclusion and $p : C \rightarrow \underline{C}$ is the projection.

In the statement of the theorem we have used the language of Dirac geometry. The condition determining $\underline{\pi}$ can be given in more detail as follows:

$$i^! \mathbb{L}_\pi = \mathbb{L}_C = p^! \mathbb{L}_{\underline{\pi}} \quad \begin{array}{ccc} & & (M, \mathbb{L}_\pi) \\ & \nearrow i & \\ (C, \mathbb{L}_C) & & \\ & \searrow p & \\ & & (\underline{C}, \mathbb{L}_{\underline{\pi}}) \end{array}$$

The intermediate Dirac structure $\mathbb{L}_C := i^! \mathbb{L}_\pi$ given by

$$\mathbb{L}_C = \{(\pi^\sharp \alpha, \alpha|_{TC}) : \alpha \in T_C^* M \text{ vanishing on } (TC)^\perp\}$$

has kernel precisely the characteristic distribution

$$\mathbb{L}_C \cap TC = \{\pi^\sharp \alpha : \alpha|_{TC} = 0\} = \mathcal{K}_C.$$

We obtain a Dirac geometric characterization of the constant rank condition:

Lemma 8.66. *The characteristic distribution \mathcal{K}_C is of constant rank if and only if \mathbb{L}_C is a smooth Dirac structure on C . In this case, \mathcal{K}_C is involutive.*

Proof. If \mathcal{K}_C has constant rank, then it follows from the general criteria of Theorem 7.33 and a dimension count as in the proof of Proposition 8.42 that \mathbb{L}_C is smooth.

For the converse, we observe that \mathcal{K}_C can be seen as both

- (i) the intersection of two smooth bundles, namely TC and \mathbb{L}_C ,
- (ii) the image of a vector bundle map, namely $\pi^\sharp : (TC)^\circ \rightarrow TC$.

Hence, the rank of \mathcal{K}_C around a point can only decrease by (i) and increase by (ii), so it must be constant.

In general, the kernel of a Dirac structure is involutive, provided it has constant rank. □

Proof of Theorem 8.65. From the general discussion on Dirac structures from Example 7.45, we obtain a Poisson structure $\underline{\pi}$ on \underline{C} such that $p_!(\mathbb{L}_C) = \mathbb{L}_{\underline{\pi}}$. By Exercise 7.46, the map is also backward Dirac: $p^!\mathbb{L}_{\underline{\pi}} = \mathbb{L}_C$. □

Example 8.67 (Hamiltonian quotients). Theorem 8.65 includes as a special case the usual symplectic reduction for a Hamiltonian G -space (Theorem B.19) and its Poisson geometric generalization. Given a Hamiltonian G -space (M, π) with moment map $\mu : (M, \pi) \rightarrow \mathfrak{g}^*$, if the action of G on $\mu^{-1}(0)$ is free and proper, then 0 is a regular value of μ and, as we saw before, $\mu^{-1}(0) \subset M$ is a coisotropic submanifold. The characteristic distribution at $x \in \mu^{-1}(0)$ is given by

$$(T_x \mu^{-1}(0))^{\perp \pi} = \pi^\sharp((T_x \mu^{-1}(0))^\circ) = \pi^\sharp((d_x \mu)^*(\mathfrak{g})) = \{X_{\mu_v}|_x : v \in \mathfrak{g}\},$$

so it coincides with the orbit distribution. Hence, in this case, if G is connected, the theorem yields a reduced Poisson structure on the usual Hamiltonian quotient:

$$\mu^{-1}(0)/(T\mu^{-1}(0))^{\perp \pi} = \mu^{-1}(0)/G = M//G.$$

When the action of G on M is proper and free, $\mu^{-1}(0)/G$ is a Poisson submanifold of M/G , as discussed in Example 8.21. 

We can combine several of the results in this section to obtain symplectic realizations of the quotient Poisson structure associated with the coisotropic submanifold.

Proposition 8.68. *Let $\mu : (S, \omega) \rightarrow (M, \pi)$ be a symplectic realization, and let $C_M \subset M$ be a coisotropic submanifold, so that $C_S := \mu^{-1}(C_M) \subset S$ is a coisotropic submanifold. Assume the following:*

- (i) *The characteristic distribution \mathcal{K}_{C_M} of C_M has constant rank.*
- (ii) *The characteristic foliations $\mathcal{K}_{C_S} = \text{Ker } \omega|_{C_S}$ and \mathcal{K}_{C_M} are simple.*

Then $\underline{C}_S := C_S/\mathcal{K}_{C_S}$ is a symplectic manifold, $\underline{C}_M := C_M/\mathcal{K}_{C_M}$ is a Poisson manifold, and μ induces a symplectic realization

$$\underline{\mu} : (\underline{C}_S, \underline{\omega}) \rightarrow (\underline{C}_M, \underline{\pi}).$$

Proof. Note that the restriction

$$\mu : (C_S, \omega|_{C_S}) \rightarrow (C_M, \mathbb{L}_{C_M})$$

is a forward Dirac map. This follows by applying Problem 7.6 to the square

$$\begin{array}{ccc} (S, \omega) & \xrightarrow{\mu} & (M, \pi) \\ \uparrow & & \uparrow \\ (C_S, \omega|_{C_S}) & \xrightarrow{\mu} & (C_M, \mathbb{L}_{C_M}) \end{array}$$

Since $C_S \subset S$ is a coisotropic submanifold in a symplectic manifold, it follows that \mathcal{K}_{C_S} has constant rank. The proof of Proposition 8.61 shows that

$$d_x \mu(\mathcal{K}_{C_S, x}) = \mathcal{K}_{C_M, \mu(x)}, \quad \forall x \in C_S.$$

This equation implies that μ takes leaves to leaves and then it descends to a smooth map $\underline{\mu} : \underline{C}_S \rightarrow \underline{C}_M$. This map is a submersion because μ and the quotient maps are all submersions. The fact that $\underline{\mu}$ is forward Poisson follows again from Problem 7.6 applied to the diagram

$$\begin{array}{ccc} (C_S, \omega|_{C_S}) & \xrightarrow{\mu} & (C_M, \mathbb{L}_{C_M}) \\ \downarrow & & \downarrow \\ (\underline{C}_S, \underline{\omega}) & \xrightarrow{\underline{\mu}} & (\underline{C}_M, \underline{\pi}) \end{array} \quad \square$$

The coisotropic reduction discussed before required the constant rank assumption on the characteristic distribution. Lemma 8.66 showed that, under this condition, a coisotropic submanifold C of (M, π) carries an induced Dirac structure \mathbb{L}_C . The **coisotropic embedding problem** addresses the converse question:

- *Which Dirac manifolds (C, \mathbb{L}_C) can be embedded coisotropically in a Poisson manifold (M, π) ?*

Example 8.69. The following special instance of this problem is well known in symplectic geometry: given a manifold C endowed with a closed 2-form $\omega_C \in \Omega^2(C)$ one looks for a symplectic manifold (M, ω) together with a coisotropic embedding $i : C \hookrightarrow M$ such that $\omega_C = i^*\omega$. Gotay’s Theorem [81] states that this is possible if and only if ω_C has constant rank. 

Generalizing Gotay’s Theorem, one has the following coisotropic embedding theorem:

Theorem 8.70 (Cattaneo and Zambon [31]). *Let (C, \mathbb{L}_C) be a Dirac manifold. There exists a Poisson manifold (M, π) and a coisotropic embedding $i : C \hookrightarrow M$ such that $\mathbb{L}_C = i^!\mathbb{L}_\pi$ if and only if $\mathbb{L}_C \cap TC$ has constant rank.*

Proof. If (M, π) is a Poisson manifold and $i : C \hookrightarrow M$ is a coisotropic embedding such that $\mathbb{L}_C = i^!\mathbb{L}_\pi$, then by Lemma 8.66 the bundle $\mathbb{L}_C \cap TC$ has constant rank.

Conversely, assume that (C, \mathbb{L}_C) is a Dirac manifold such that $\mathcal{K}_C := \mathbb{L}_C \cap TC$ is of constant rank. Choose a subbundle $D \subset TC$ such that

$$(8.5) \quad TC = \mathcal{K}_C \oplus D.$$

This gives an embedding of the dual vector bundle $j : \mathcal{K}_C^* \hookrightarrow T^*C$. Denote by $B = j^*\omega_{\text{can}}$ the pullback of the canonical symplectic form and define a Dirac structure on the total space of \mathcal{K}_C^* by

$$\mathbb{L} := e^B \text{pr}^! \mathbb{L}_C$$

where $\text{pr} : \mathcal{K}_C^* \rightarrow C$ is the bundle projection. Let $i : C \hookrightarrow \mathcal{K}_C^*$ be the zero section. We claim the following:

- (i) $i^!\mathbb{L} = \mathbb{L}_C$.
- (ii) $(T_x \mathcal{K}_C^*) \cap \mathbb{L}_x = \{0\}$ for all $x \in i(C)$.
- (iii) If $\alpha \in (Ti(C))^\circ$ and $v + \alpha \in \mathbb{L}$, then $v \in Ti(C)$.

Assuming these claims, we can finish the proof by observing that: by (ii) there is an open neighborhood $M \subset \mathcal{K}_C^*$ of the zero section where $\mathbb{L} = \mathbb{L}_\pi$ for a Poisson structure $\pi \in \mathfrak{X}^2(M)$; by (iii) the zero section $i : C \hookrightarrow M$ is a coisotropic embedding; and by (i) we have $i^!\mathbb{L}_\pi = \mathbb{L}_C$.

Now, (i) follows from the straightforward computation

$$i^!\mathbb{L} = i^!(e^B \text{pr}^! \mathbb{L}_C) = e^{i^*B} i^! \text{pr}^! \mathbb{L}_C = e^0 (\text{pr} \circ i)^! \mathbb{L}_C = \mathbb{L}_C,$$

where we used that $j \circ i : C \rightarrow T^*C$ is the zero section, so

$$i^*B = (j \circ i)^* \omega_{\text{can}} = 0.$$

To prove (ii), we observe that

$$\begin{aligned} v \in \mathbb{L} \cap T_{i(C)}\mathcal{K}_C^* &\iff v - i_v B \in \text{pr}^! \mathbb{L}_C \\ &\iff -i_v B = \text{pr}^* \alpha \text{ and } d \text{pr}(v) + \alpha \in \mathbb{L}_C. \end{aligned}$$

The decomposition (8.5) gives

$$(8.6) \quad T_{i(C)}\mathcal{K}_C^* = \mathcal{K}_C^* \oplus TC = \mathcal{K}_C^* \oplus \mathcal{K}_C \oplus D,$$

where $D = \text{Ker } B$ and relative to which B is the canonical symplectic form on the first two factors. Therefore, we obtain

$$-i_v B = \text{pr}^* \alpha \implies d \text{pr}(v) + \alpha \in D + D^\circ.$$

But by Problem 7.1, we have $\mathbb{L}_C \cap (D + D^\circ) = \{0\}$. So we obtain

$$v \in \mathbb{L} \cap T_{i(C)}\mathcal{K}_C^* \implies v \in \text{Ker}(d \text{pr}) \cap \text{Ker}(B) \implies v = 0,$$

so (ii) holds.

Finally, to prove (iii), notice that if $v + \alpha \in \mathbb{L}$, then $i_v B - \alpha = \text{pr}^* \beta$, for some $\beta \in T^*C$. Additionally if $\alpha \in (Ti(C))^\circ$, then we must have

$$i_v B(w) = \text{pr}^* \beta(w), \quad \forall w \in Ti(C).$$

From (8.6), we conclude that $v \in D \subset TC$, so (iii) holds. □

8.5. Example: Fixed point sets

We will now discuss an interesting way to obtain submanifolds of the types introduced in this chapter as fixed point sets.

Consider an involution $\tau : M \rightarrow M$, i.e., a diffeomorphism such that $\tau^2 = \text{Id}$. Each connected component of the fixed point set of τ ,

$$M_0 = \{x \in M : \tau(x) = x\},$$

is an embedded submanifold, with tangent bundle the fixed point set of $d\tau$,

$$TM_0 = \{v \in T_{M_0}M : d\tau(v) = v\}.$$

Note that the connected components can have distinct dimensions.

If (M, π) is a Poisson manifold, we say that τ is a **Poisson involution** if $\tau^* \pi = \pi$ and an **anti-Poisson involution** if $\tau^* \pi = -\pi$.

Proposition 8.71. *Let (M, π) be a Poisson manifold, and let $\tau : M \rightarrow M$ be a Poisson involution. Then the connected components of the fixed point set M_0 of τ are Poisson-Dirac submanifolds.*

On the other hand, if τ is an anti-Poisson involution, then the connected components of M_0 are coisotropic submanifolds.

Proof. At a fixed point $x \in M_0$, we have $(d_x\tau)^2 = \text{Id}$. Hence the tangent space at such a point decomposes into the ± 1 -eigenspaces of $d_x\tau$,

$$T_xM = (T_xM)^+ \oplus (T_xM)^-, \quad (T_xM)^\pm := \{v \in T_xM : d_x\tau(v) = \pm v\},$$

and $T_xM_0 = (T_xM)^+$. Similarly, the cotangent spaces decompose as

$$T_x^*M = (T_x^*M)^+ \oplus (T_x^*M)^-, \quad (T_x^*M)^\pm := \{\alpha \in T_x^*M : (d_x\tau)^*(\alpha) = \pm\alpha\},$$

and we have $T_x^*M_0 = (T_x^*M)^+$, $(T_xM_0)^\circ = (T_x^*M)^-$. Since τ is a Poisson map, we have

$$\pi_x^\sharp = d_x\tau \circ \pi_x^\sharp \circ (d_x\tau)^* \quad (x \in M_0)$$

and it follows that

$$(8.7) \quad \pi^\sharp((T_xM)^\pm) \subset (T_xM)^\pm.$$

Therefore,

$$(T_xM_0)^{\perp\pi} = \pi^\sharp((T_xM_0)^\circ) = \pi^\sharp((T_x^*M)^-) \subset (T_xM)^-.$$

Hence the first condition in Proposition 8.30 is satisfied. For the second condition we observe that the projection $p^+ : T_xM \rightarrow (T_xM)^+$ gives a canonical way of extending $\xi \in T_x^*M_0$ to a covector $\tilde{\xi} := p_+^*(\xi) \in T_x^*M$. The resulting π_0 on M_0 given by (8.3) is then smooth.

On the other hand, if τ is an anti-Poisson map, we find

$$(8.8) \quad \pi^\sharp((T_x^*M)^\pm) \subset (T_xM)^\mp \quad (x \in M_0).$$

Hence, in this case we obtain $(T_xM_0)^{\perp\pi} \subset (T_xM)^+ = T_xM_0$, which is the condition for M_0 to be coisotropic. \square

Corollary 8.72. *If $\tau : (M, \pi) \rightarrow (M, \pi)$ is a Poisson involution, then the fixed point set M_0 is a Poisson transversal if and only if*

$$\text{Ker } \pi_x^\sharp \cap (T_xM_0)^\circ = \{0\}, \quad \forall x \in M_0.$$

Proof. In the previous proof we saw that

$$(T_xM_0)^{\perp\pi} \subset (T_xM)^- \quad \text{and} \quad \pi^\sharp((T_x^*M)^\pm) \subset (T_xM)^\pm \quad (x \in M_0).$$

So M_0 is a Poisson transversal iff $(T_xM_0)^{\perp\pi} = (T_xM)^-$ or, equivalently, if π^\sharp restricts to an isomorphism $(T_xM_0)^\circ \rightarrow (T_xM)^-$ (by a dimension count). \square

Exercise 8.73. Show that any Poisson structure on a Lie group G for which the inversion $\iota : G \rightarrow G$ is an anti-Poisson map must vanish at the unit.

Exercise 8.74. Show that if $\tau : (M, \pi) \rightarrow (M, \pi)$ is a Poisson involution, then the induced Poisson bracket on the fixed point set M_0 is given by

$$\{f_1, f_2\}_{M_0} = \{\bar{f}_1, \bar{f}_2\}|_{M_0},$$

where $\bar{f}_i \in C^\infty(M)$ is any τ -invariant smooth extension of $f_i \in C^\infty(M_0)$. You need to show that such extensions exist!

Example 8.75 (Involutions on Lie algebras). Let $\tau : \mathfrak{g} \rightarrow \mathfrak{g}$ be a linear involution of a Lie algebra \mathfrak{g} . Decompose \mathfrak{g} into the ± 1 -eigenspaces of τ :

$$\mathfrak{g} = \mathfrak{h} \oplus \mathfrak{p}.$$

Then \mathfrak{h} is the fixed point set of τ , while \mathfrak{p}° is the fixed point set of the transpose $\tau^* : \mathfrak{g}^* \rightarrow \mathfrak{g}^*$.

Now, the transpose $\tau^* : \mathfrak{g}^* \rightarrow \mathfrak{g}^*$ is a Poisson involution if and only if τ is a Lie algebra automorphism, and this is equivalent to

$$[\mathfrak{h}, \mathfrak{h}] \subset \mathfrak{h}, \quad [\mathfrak{h}, \mathfrak{p}] \subset \mathfrak{p}, \quad [\mathfrak{p}, \mathfrak{p}] \subset \mathfrak{h}.$$

The proposition says that then $M_0 = \mathfrak{p}^\circ \subset \mathfrak{g}^*$ is a Poisson-Dirac submanifold, and this matches what we saw in Example 8.36. Note also that, by Example 8.16, \mathfrak{p}° is a Poisson submanifold if and only if $[\mathfrak{p}, \mathfrak{p}] = 0$. Moreover, \mathfrak{p}° is a Poisson transversal only when $\mathfrak{p} = 0$, and so $\tau = \text{Id}$.

On the other hand, the transpose $\tau^* : \mathfrak{g}^* \rightarrow \mathfrak{g}^*$ is an anti-Poisson involution if and only if τ is a Lie algebra anti-automorphism, and this is equivalent to

$$[\mathfrak{h}, \mathfrak{h}] \subset \mathfrak{p}, \quad [\mathfrak{h}, \mathfrak{p}] \subset \mathfrak{h}, \quad [\mathfrak{p}, \mathfrak{p}] \subset \mathfrak{p}.$$

The proposition says that $M_0 = \mathfrak{p}^\circ$ is a coisotropic submanifold of \mathfrak{g}^* , and this matches what we saw in Example 8.57. 

Example 8.76. Consider the LV-type Poisson structure in \mathbb{R}^4 given in Example 8.39. One checks immediately that the map

$$\tau : \mathbb{R}^4 \rightarrow \mathbb{R}^4, \quad (x, y, z, w) \mapsto (z, w, x, y),$$

is a Poisson involution. The fixed point set is precisely the Poisson-Dirac submanifold $N \subset \mathbb{R}^4$ considered in that example. This is not a Poisson transversal since it includes a zero of the ambient Poisson structure — or use the corollary above. We extend the coordinates (u, v) on N to τ -invariant functions on \mathbb{R}^4 :

$$\bar{u}(x, y, z, w) = \frac{x+z}{2}, \quad \bar{v}(x, y, z, w) = \frac{y+w}{2},$$

and we compute their Poisson bracket

$$\{\bar{u}, \bar{v}\} = \frac{1}{4}\{x+z, y+w\} = \frac{1}{4}(xy+xw+zy+zw) = \bar{u}\bar{v}.$$

Therefore, by Exercise 8.74, the Poisson bracket on N is $\{u, v\} = uv$, which coincides with the one found in Example 8.39. 

If we regard an involution as a \mathbb{Z}_2 -action, Proposition 8.71 admits the following generalization:

Proposition 8.77. *Consider an action of a compact Lie group G on a Poisson manifold (M, π) by Poisson diffeomorphisms. Each connected component of the fixed point set*

$$M^G := \{x \in M : g \cdot x = x, \forall g \in G\}$$

is a Poisson-Dirac submanifold. It is a Poisson transversal if and only if

$$\text{Ker } \pi^\sharp \cap (TM^G)^\circ = 0.$$

Proof. Recall that since G is compact, the fixed point set M^G is a submanifold — possibly with connected components of different dimensions. Its tangent bundle is the fixed point set of the lifted action of G on TM :

$$TM^G = (TM)^G.$$

Also, M has a G -invariant Riemannian metric, and if E denotes the orthogonal bundle to TM^G , we have a G -invariant decomposition

$$T_{MG}M = TM^G \oplus E.$$

We also have the dual decomposition of the cotangent bundles

$$T_{MG}^*M = E^\circ \oplus (TM^G)^\circ,$$

where $E^\circ = (T^*M)^G$ coincides with fixed point set of the lifted action of G on T^*M . In particular, notice that these decompositions are independent of the choice of invariant metric.

Now, the G -equivariance of $\pi^\sharp : T^*M \rightarrow TM$ implies that

$$\pi^\sharp(E^\circ) \subset TM^G, \quad \pi^\sharp((TM^G)^\circ) \subset E.$$

Hence the first condition in Proposition 8.30 is satisfied. For the second condition we observe that the projection $p : T_x M \rightarrow T_x M^G$ gives a canonical way of extending $\xi \in T_x^* M^G$ to a covector $\tilde{\xi} := p^*(\xi) \in T_x^* M$. The resulting Poisson structure on M^G given by (8.3) is then smooth.

Since $T_{MG}M = TM^G \oplus E$ and $(TM^G)^\perp = \pi^\sharp((TM^G)^\circ) \subset E$, we see that M^G is a Poisson transversal if and only if the restriction of π^\sharp to $(TM^G)^\circ$ is an isomorphism, which is equivalent to the condition in the proposition (by dimension count). \square

Exercise 8.78. Show that, under the conditions of the proposition, the Poisson bracket on the fixed point set M^G is given by

$$\{f_1, f_2\}_{MG} = \{\bar{f}_1, \bar{f}_2\}|_{MG},$$

where $\bar{f}_i \in C^\infty(M)$ is any G -invariant smooth extension of $f_i \in C^\infty(M^G)$.

NOTE: For a compact Lie group, G -invariant extensions can always be constructed by taking any smooth extension \tilde{f}_i and then averaging over G :

$$\bar{f}_i(x) := \int_G \tilde{f}_i(gx) dg,$$

where dg is the normalized Haar measure on G (i.e., $\int_G dg = 1$).

Example 8.79. For a symplectic action, the previous proposition becomes a standard result in symplectic geometry that ensures that the fixed point set of a symplectic action of a compact Lie group is a symplectic submanifold. So, in this case, the fixed point set is a Poisson transversal. 

Exercise 8.80. Consider the coadjoint action $G \times \mathfrak{g}^* \rightarrow \mathfrak{g}^*$. This is a Poisson action on $(\mathfrak{g}^*, \pi_{\mathfrak{g}})$. Find the Poisson structure on the fixed Poisson set.

8.6. Pre-Poisson submanifolds

Definition 8.81. A **pre-Poisson submanifold** of a Poisson manifold (M, π_M) is a submanifold $P \subset M$ with the property that

$$TP + (TP)^{\perp\pi} \subset TM$$

is of constant rank.

Note that a Poisson-Dirac submanifold P is a pre-Poisson submanifold if and only if it is coregular. Hence, Figure 8.1 illustrates all the different types of submanifolds of Poisson manifolds that we have introduced:

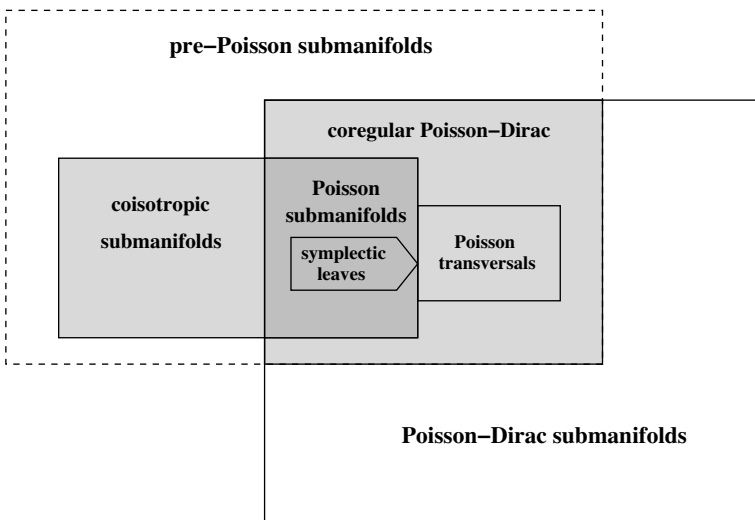



Figure 8.1. Submanifolds of a Poisson manifold

Notice that a submanifold is both a Poisson submanifold and a Poisson transversal if and only if it is an open subset. The tangent overlap between these two classes in Figure 8.1 represents this intersection.

Example 8.82 (Symplectic structures). For a symplectic manifold (S, ω) a submanifold $P \subset S$ is a pre-Poisson submanifold if and only if $\omega|_P$ has constant rank. In symplectic geometry, these are sometimes called *presymplectic submanifolds*, which is the origin of the name “pre-Poisson submanifold”. In this case, the diagram above simplifies considerably, since for a submanifold of S one has the equivalences

$$\begin{array}{ccccccc} \text{symplectic} & \iff & \text{Poisson} & \iff & \text{Poisson-Dirac} & \iff & \text{coregular} \\ \text{submanifold} & & \text{transversal} & & \text{submanifold} & & \text{Poisson-Dirac.} \end{array}$$

Moreover, the symplectic leaves are the connected components of S , while the Poisson submanifolds are the open subsets of S . 

Example 8.83 (Linear Poisson structures). Let $(\mathfrak{g}^*, \pi_{\mathfrak{g}})$ be a linear Poisson manifold. As we saw in Example 8.16 for a subspace $\mathfrak{h}^\circ \subset \mathfrak{g}^*$ we have

$$(T_\xi \mathfrak{h}^\circ)^{\perp \pi_{\mathfrak{g}}} = \{\text{ad}_u^*(\xi) : u \in \mathfrak{h}\}.$$

So $\mathfrak{h}^\circ \subset \mathfrak{g}^*$ is pre-Poisson submanifold if and only if the subspaces

$$\{\text{ad}_u^*(\xi) : u \in \mathfrak{h}\} + \mathfrak{h}^\circ \subset \mathfrak{g}$$

have dimension independent of ξ . Since for $\xi = 0$ this subspace is \mathfrak{h}° , the condition becomes

$$\{\text{ad}_u^*(\xi) : u \in \mathfrak{h}\} \subset \mathfrak{h}^\circ,$$

or, in other words, that \mathfrak{h} is a Lie subalgebra of \mathfrak{g} . As we saw in Example 8.57, this is the condition for $\mathfrak{h}^\circ \subset \mathfrak{g}^*$ to be a coisotropic submanifold:

$$\begin{array}{ccccc} \mathfrak{h}^\circ \text{ is coisotropic} & \iff & \mathfrak{h}^\circ \text{ is pre-Poisson} & \iff & \mathfrak{h} \subset \mathfrak{g} \text{ is Lie} \\ \text{submanifold} & & \text{submanifold} & & \text{subalgebra.} \end{array}$$

Taking into consideration also Example 8.16 one has the equivalences

$$\begin{array}{ccccc} \mathfrak{h}^\circ \text{ is Poisson} & \iff & \mathfrak{h}^\circ \text{ is coregular} & \iff & \mathfrak{h} \subset \mathfrak{g} \text{ is Lie} \\ \text{submanifold} & & \text{Poisson-Dirac} & & \text{ideal.} \end{array}$$

Also, since linear Poisson structures vanish at the origin, $\mathfrak{h}^\circ \subset \mathfrak{g}^*$ is a Poisson transversal only if $\mathfrak{h} = \{0\}$. Finally, in Example 8.36 we saw that

$$\begin{array}{ccc} \mathfrak{h} \subset \mathfrak{g} \text{ has a complement } \mathfrak{k} & \implies & \mathfrak{h}^\circ \text{ is Poisson-Dirac} \\ \text{such that } [\mathfrak{h}, \mathfrak{k}] \subset \mathfrak{h} & & \text{submanifold.} \end{array} \quad \img alt="fish icon" data-bbox="825 795 855 815"/>$$

For a Poisson manifold (M, π) , it is not hard to see that if a submanifold is a coisotropic submanifold of a Poisson transversal of M , then it is pre-Poisson. The following theorem shows that this actually characterizes pre-Poisson submanifolds and should be compared to Theorem 8.44.

Theorem 8.84 (Cattaneo and Zambon [31]). *For any embedded submanifold P of a Poisson manifold (M, π) the following are equivalent:*

- (i) P is a pre-Poisson submanifold.
- (ii) P is a coisotropic submanifold inside some Poisson transversal X .

Moreover, the germ of X around P is unique up to Poisson diffeomorphisms.

Proof. (i) \Rightarrow (ii). If P is a pre-Poisson submanifold, then $U := TP + (TP)^\perp{}^\pi$ is a vector bundle. Consider the surjective map

$$(8.9) \quad (TP)^\circ \rightarrow U/TP, \quad \alpha \mapsto \pi^\sharp(\alpha) \bmod TP.$$

The kernel of this map is precisely U° , as can be seen using the relation

$$((TP)^\perp{}^\pi)^\circ = (\pi^\sharp)^{-1}(TP).$$

Let $V \subset T_P M$ be a subbundle such that $(TP)^\circ = V^\circ \oplus U^\circ$. Passing to the annihilators, this decomposition is equivalent to the conditions

$$T_P M = V + U \quad \text{and} \quad TP = V \cap U.$$

Since the map in (8.9) restricted to V° is a bijection, we have that

$$(8.10) \quad U = TP \oplus V^\perp{}^\pi.$$

These decompositions yield

$$T_P M = V \oplus V^\perp{}^\pi.$$

Choose a small enough submanifold $P \subset X \subset M$ with $T_P X = V$. Then X is a Poisson transversal in M . Moreover, P is a coisotropic submanifold of X because along P the Poisson structure $\pi_X^\sharp : T_P^* X \rightarrow T_P X$ coincides with $\pi^\sharp|_{(V^\perp{}^\pi)^\circ}$, via the identification $T_P^* X = V^* \simeq (V^\perp{}^\pi)^\circ$. Hence, passing to the annihilators in (8.10) and using that U° is the kernel of the map (8.9), we obtain

$$\pi^\sharp((TP)^\circ \cap (V^\perp{}^\pi)^\circ) = \pi^\sharp(U^\circ) \subset TP.$$

(ii) \Rightarrow (i). Let $P \subset M$ be a submanifold, and assume there exists a Poisson transversal X of (M, π) such that $P \subset X$ is a coisotropic submanifold of X . We claim that

$$TP + (TP)^\perp{}^\pi = TP \oplus (T_P X)^\perp{}^\pi,$$

so $TP + (TP)^\perp{}^\pi$ has constant rank; hence P is a pre-Poisson submanifold of (M, π) .

To prove the claim, we first observe that the right-hand side is indeed a direct sum because $P \subset X$ and X is a Poisson transversal. Moreover, we also have $(T_P X)^\perp{}^\pi \subset (TP)^\perp{}^\pi$ and so the right-hand side is contained in the

left-hand side. For the opposite inclusion, we again use $(T_P X)^{\perp\pi} \subset (TP)^{\perp\pi}$ and that X is a Poisson transversal to obtain

$$(TP)^{\perp\pi} = (T_P X)^{\perp\pi} \oplus ((TP)^{\perp\pi} \cap T_P X).$$

If we now use the condition that $P \subset X$ is a coisotropic submanifold,

$$(TP)^{\perp\pi} \cap T_P X \subset TP,$$

we obtain the reverse inclusion.

The proof of uniqueness of the germ of X around P is left as an exercise — see Problem 8.13. □

Many of the results that we have obtained for coisotropic submanifolds have a direct analog in the setting of pre-Poisson submanifolds. The proofs can be obtained either by adapting those from the coisotropic case or by applying those results directly to the submanifold when viewed as a coisotropic inside a Poisson transversal, as in the previous theorem. For this reason, the details will be omitted.

First we consider the behavior of pre-Poisson submanifolds under Poisson maps.

Proposition 8.85. *Let $\Phi : (M, \pi_M) \rightarrow (N, \pi_N)$ be a Poisson map, and assume that Φ is transverse to a submanifold $P \subset N$. If P is a pre-Poisson submanifold, then so is $\Phi^{-1}(P)$. The converse holds when $P \subset \Phi(M)$.*

This proposition generalizes not just the case of coisotropic submanifolds, but also the one for Poisson transversals — just that in the latter case, transversality held automatically.

Next, pre-Poisson submanifolds still give rise to Poisson structures by reduction.

Theorem 8.86 (Pre-Poisson reduction). *Let P be a pre-Poisson submanifold of (M, π) , and assume that the **characteristic distribution***

$$\mathcal{K}_P := TP \cap (TP)^{\perp\pi} \subset TP$$

has constant rank. Then:

- (i) \mathcal{K}_P defines a regular foliation.
- (ii) If this foliation is simple, then its leaf space $\underline{P} := P/\mathcal{K}_P$ carries a unique Poisson structure $\underline{\pi} \in \mathfrak{X}^2(\underline{P})$ satisfying

$$p^! \mathbb{L}_{\underline{\pi}} = i^! \mathbb{L}_{\pi},$$

where $i : P \hookrightarrow M$ is the inclusion and $p : P \rightarrow \underline{P}$ is the projection.

The proof of this theorem is entirely similar to that of Theorem 8.65. The Dirac structures can be represented by the diagram

$$i^!\mathbb{L}_\pi = \mathbb{L}_P = p^!\mathbb{L}_\pi \quad \begin{array}{ccc} & & (M, \mathbb{L}_\pi) \\ & \nearrow i & \\ (P, \mathbb{L}_P) & & \\ & \searrow p & \\ & & (\underline{P}, \underline{\mathbb{L}}_\pi) \end{array}$$

where the inclusion is backward Dirac and the projection is forward and backward Dirac.

Finally, we look at the interaction with presymplectic realizations and reduction.

Proposition 8.87. *Let $\mu : (S, \omega) \rightarrow (M, \pi)$ be a symplectic realization, and let $P_M \subset M$ be a pre-Poisson submanifold, so that $P_S := \mu^{-1}(P_M) \subset S$ is a pre-Poisson submanifold. Assume the following:*

- (i) *The characteristic distribution \mathcal{K}_{P_M} of P_M has constant rank.*
- (ii) *The characteristic foliations $\mathcal{K}_{P_S} = \text{Ker } \omega|_{P_S}$ and \mathcal{K}_{P_M} are simple.*

Then $\underline{P}_S := P_S/\mathcal{K}_{P_S}$ is a symplectic manifold, $\underline{P}_M := P_M/\mathcal{K}_{P_M}$ is a Poisson manifold, and $\underline{\mu}$ induces a symplectic realization

$$\underline{\mu} : (\underline{P}_S, \underline{\omega}) \rightarrow (\underline{P}_M, \underline{\pi}).$$

This result puts together the constructions of realizations for Poisson transversals (Proposition 6.2), Poisson submanifolds (Proposition 8.22), and coregular Poisson-Dirac submanifolds (Remark 8.49).

Observing that the restriction $\mu : (P_S, \omega|_{P_S}) \rightarrow (P_M, \mathbb{L}_{P_M})$ can be viewed as a “presymplectic realization” of the pre-Poisson submanifold P_M , this construction is described by the following diagram of (pre-)symplectic realizations and reductions:

$$\begin{array}{ccccc} & & (S, \omega) & \xrightarrow{\mu} & (M, \pi) \\ & \nearrow & & & \nearrow \\ (P_S, \omega|_{P_S}) & \xrightarrow{\mu} & (P_M, \mathbb{L}_{P_M}) & & \\ & \searrow & & & \searrow \\ & & (\underline{P}_S, \underline{\omega}) & \xrightarrow{\underline{\mu}} & (\underline{P}_M, \underline{\pi}) \end{array}$$

Problems

8.1. Let \mathfrak{g} be a Lie algebra with a vector space decomposition $\mathfrak{g} = \mathfrak{h} \oplus \mathfrak{k}$ satisfying $[\mathfrak{h}, \mathfrak{k}] \subset \mathfrak{h}$, as in Example 8.36. Show that the induced Poisson structure on the Poisson-Dirac manifold $\mathfrak{h}^\circ \subset \mathfrak{g}^*$ is linear. If \mathfrak{k} is Lie algebra, verify that the resulting linear Poisson structure is isomorphic to $(\mathfrak{k}^*, \pi_{\mathfrak{k}})$.

8.2. Observe that Poisson-Dirac submanifolds of Poisson-Dirac submanifolds are Poisson-Dirac submanifolds of the ambient manifold. Similarly, show that the following classes are closed under inclusion:

- (a) Poisson submanifolds,
- (b) Poisson transversals,
- (c) coregular Poisson-Dirac submanifolds.

8.3. Let $\Phi : (M, \pi_M) \rightarrow (N, \pi_N)$ be a Poisson map which is an immersion. Show that $\text{Graph}(\Phi) \subset (M, \pi_M) \times (N, -\pi_N)$ is a Lagrangian submanifold — see the discussion following Definition 8.50.

8.4. Let $\Phi : (M, \pi_M) \rightarrow (N, \pi_N)$ be a Poisson map which is a surjective submersion, and let $C \subset N$ be a submanifold. If $\Phi^{-1}(C) \subset M$ is a Lagrangian submanifold, show that $C \subset N$ is also a Lagrangian submanifold. Give an example showing that the converse may fail.

8.5. Show that a submanifold of a Poisson manifold (M, π) is a Poisson submanifold if and only if it is both a coisotropic and a Poisson-Dirac submanifold.

8.6. Let (M, π) be a Poisson manifold. Show the following:

- (a) If N is an immersed Poisson submanifold of (M, π) which is closed as a subset of M , then N is a complete Poisson submanifold.
- (b) If $\{N_i\}_{i \in I}$ is a partition of (M, π) into immersed Poisson submanifolds, then each N_i is a complete Poisson submanifold.

HINT: Use Exercise 8.8.

8.7. Let $(M \times \mathfrak{g}^*, \Pi_{\mathfrak{g}, \mathcal{a}})$ be the Poisson manifold associated to an infinitesimal Poisson action $\mathcal{a} : \mathfrak{g} \rightarrow \mathfrak{X}(M, \pi)$ as in Problem 2.11. Consider the slices

$$M_\xi := M \times \{\xi\} \subset M \times \mathfrak{g}^* \quad (\xi \in \mathfrak{g}^*).$$

- (a) Show that M_0 is always a coisotropic submanifold.
- (b) Show that M_ξ is a Poisson-Dirac submanifold if and only if $\mathcal{a}(\mathfrak{g}_\xi) = 0$.
- (c) When is M_ξ a Poisson transversal?

8.8. Assume that the action in the previous problem comes from an action of a connected, compact Lie group $G \times M \rightarrow M$. Show that

$$(M \times \mathfrak{g}^*)^G = M^G \times [\mathfrak{g}, \mathfrak{g}]^\circ$$

and find the Poisson structure on this Poisson-Dirac submanifold.

8.9. Given manifolds M and N a (smooth) **relation** $R : M \rightarrow N$ is a submanifold $R \subset M \times N$. Given a relation $R : M \rightarrow N$, we denote by $R^{-1} : N \rightarrow M$ the inverse relation

$$R^{-1} := \{(y, x) \in N \times M : (x, y) \in R\}.$$

If $R : M \rightarrow N$ and $S : N \rightarrow P$ are relations, the **composite relation** $S \circ R : M \rightarrow P$ defined by

$$S \circ R := \{(x, z) \in M \times P : \exists y \in N \text{ such that } (x, y) \in R \text{ and } (y, z) \in S\}$$

may fail to be a submanifold. We say that two relations $R : M \rightarrow N$ and $S : N \rightarrow P$ meet **cleanly** if $R \circ S$ is a submanifold of $M \times P$ and for each $(x, y) \in R$ and $(y, z) \in S$ we have

$$T_{(x,z)}(S \circ R) = T_{(y,z)}S \circ T_{(x,y)}R.$$

If (M, π_M) and (N, π_N) are Poisson manifolds, a **Poisson relation** is a coisotropic submanifold $R \subset (M, \pi_M) \times (N, -\pi_N)$. Show the following:

- If $R : M \rightarrow N$ is a Poisson relation, the inverse $R^{-1} : N \rightarrow M$ is also a Poisson relation.
- Each coisotropic submanifold $C \subset (M, \pi_M)$ gives rise to a Poisson relation $R(C) : (\{*\}, 0) \rightarrow (M, \pi_M)$.
- A map $\Phi : (M, \pi_M) \rightarrow (N, \pi_N)$ is Poisson if and only if $\text{Graph}(\Phi)$ is a Poisson relation.
- If $R : (M, \pi_M) \rightarrow (N, \pi_N)$ and $S : (N, \pi_N) \rightarrow (P, \pi_P)$ are Poisson relations which meet cleanly, then $S \circ R : M \rightarrow P$ is a Poisson relation.

8.10. Let (M, π_M) be a Poisson manifold. Show that a surjective submersion $\Phi : M \rightarrow N$ is a Poisson map for some Poisson structure $\pi_N \in \mathfrak{X}^2(N)$ if and only if $\Phi^{-1} \circ \Phi : M \rightarrow M$ is a Poisson relation (see Problem 8.9).

8.11. Let $\mathfrak{h} \subset \mathfrak{g}$ be a Lie subalgebra. Consider an affine subspace $\xi + \mathfrak{h}^\circ \subset \mathfrak{g}^*$.

- Show that $\xi + \mathfrak{h}^\circ \subset \mathfrak{g}^*$ is a coisotropic submanifold iff $\xi \in [\mathfrak{h}, \mathfrak{h}]^\circ$.
- Show that $\xi + \mathfrak{h}^\circ \subset \mathfrak{g}^*$ is always a pre-Poisson submanifold.
- Find a Poisson transversal in \mathfrak{g}^* that contains $\xi + \mathfrak{h}^\circ$ as a coisotropic submanifold.

8.12. Let (P, \mathbb{L}_P) be a Dirac manifold. Show that there exists a Poisson manifold (M, π) and a pre-Poisson embedding $i : P \hookrightarrow M$ with $\mathbb{L}_P = i^! \mathbb{L}_\pi$ if and only if $\mathbb{L}_P \cap TP$ has constant rank.

8.13. Let P be an embedded pre-Poisson submanifold of (M, π) , and denote $U := TP + (TP)^\perp \subset T_P M$.

(a) Consider an embedded submanifold $P \subset X \subset M$, and denote $V := T_P X \subset T_P M$. Prove that the following are equivalent:

(i) A neighborhood of P in X is a Poisson transversal in which P is a coisotropic submanifold.

(ii) $(TP)^\circ = V^\circ \oplus U^\circ$.

(HINT: Look at the proof of Theorem 8.84.)

(b) Consider two embedded Poisson transversals $X_0, X_1 \subset M$ such that P is a coisotropic submanifold in both. Show that, after possibly shrinking X_0 and X_1 , there exists a smooth family of Poisson transversals $\{X_t\}_{t \in [0,1]}$ connecting them and such that P is a coisotropic submanifold in each X_t .

(HINT: Use a tubular neighborhood adapted to X_0 and part (a) to reduce to the case when $T_P X_0 = T_P X_1$.)

(c) Prove the uniqueness assertions of Theorems 8.44 and 8.84.

(HINT: Use (b) and Problem 5.9.)

Notes and References for Part 2

The existence of symplectic leaves underlying any Poisson manifold was first proved by Kirillov [98], possibly inspired by the symplectic structure on the coadjoint orbits of a Lie algebra. The version discussed in this text is, essentially, the one given by Weinstein in [147], but for the smooth structure on the leaves we present a self-contained proof. The linear Poisson structure on the dual of a Lie algebra goes back to Sophus Lie, as we have already observed in Part 1, and the symplectic structure on coadjoint orbits was rediscovered in the 1960s by Kirillov [97], Kostant [103], and Souriau [136].

As one could expect, the study of regular Poisson structures evolved faster than the study of general Poisson structures. For example, a Moser stability theorem for regular Poisson structures was obtained by Hector et al. in [89], while the general case, which will be discussed in Chapter 9, appears only in the work of Ginzburg and Weinstein [80] and later in [44]. However, even in the realm of regular Poisson structures one runs quickly into difficult questions. For example, there is a simple criterion due to Thurston to decide whether a manifold carries a codimension-1 foliation, but no general criteria is known for the existence of a Poisson structure of corank 1. As pointed out in Chapter 4, even in the case of spheres, existence is only known for \mathbb{S}^1 (obvious), \mathbb{S}^3 (the Reeb foliation), and \mathbb{S}^5 (Mitsumatsu [121]).

The notion of transverse Poisson structure appears first in Weinstein's paper [147] and since then it has been the subject numerous studies, in particular for coadjoint orbits (see, e.g., [50] and references therein). In Weinstein [147], it was wrongly claimed that the transverse Poisson structure to any coadjoint orbit is linearizable, but a counterexample was given

by A. B. Givental [148, 149] — which appears as Exercise 5.28. Poisson transversals also appeared first in [147], where they were not named. They are sometimes known as “cosymplectic submanifolds”, but since the notion of a cosymplectic manifold has a well-established, distinct meaning, the term Poisson transversal was proposed in [71] and now seems to have universal acceptance.

As with many other basic notions in Poisson geometry, symplectic realizations were introduced by Weinstein in [147], where their local existence is proven. They were defined and studied independently by Karasev and Maslov [94, 96] — who called them *phase spaces* — under the additional assumption that they admit a Lagrangian section. The proof of local existence given here is more recent and is a specialization of the global existence proof given in [48], to be discussed in Chapter 11. Libermann’s Theorem appeared first in the note [108]. Symplectic realizations were extensively studied by Dazord and his coauthors in connection with noncommutative integrable systems (see, e.g., [53] and references therein).

Dirac structures were first introduced by T. Courant [38, 39] to give a geometric formalization of Dirac’s theory of constraints in classical mechanical systems. In the last two decades they have been shown to be relevant to a broad range of topics in mathematics and mathematical physics. For example, their complex version plays a major role in the generalized complex geometry of Gualtieri and Hitchin [83]. Our brief treatment is aimed exclusively at those aspects directly relevant to Poisson geometry. More thorough introductions and references to their applications can be found in the surveys of Bursztyn [21] and Meinrenken [119].

The notion of a Poisson submanifold appears already in [147], where its basic properties are established. Coisotropic submanifolds were also introduced by Weinstein in [152], with the express aim of “extending the lagrangian calculus from symplectic to Poisson manifolds”. The notion of a Poisson-Dirac submanifold has its origins in the work of Xu [161], who considered a special case of this notion. General Poisson-Dirac submanifolds were introduced in [42], where the coregular case is also studied, albeit under the name *constant rank*. We borrow the term *coregular* from the recent work of Brambila, Frejlich, and Martinez-Torres [17]. Poisson involutions and anti-involutions, along with their fixed point set, were first studied in [64, 68] in connection with integrable systems, and they were studied further by Xu [161]. Pre-Poisson submanifolds were introduced and studied by Cattaneo and Zambon [31] in their solution of the coisotropic embedding problem for Poisson manifolds.

Part 3

Global Aspects

We now turn to the study of global properties of Poisson manifolds. The study of such properties must take into account the presence of three different ingredients: the symplectic geometry of the leaves, the topology of the foliation, and the geometry transverse to the leaves. In the next chapters we will develop a variety of techniques and tools to explore global Poisson geometry and topology.

Poisson Cohomology

9.1. The cotangent Lie algebroid

Many constructions in classical differential geometry rely on the Lie bracket of vector fields. This operation makes the space of vector fields a Lie algebra and, furthermore, it satisfies the Leibniz identity

$$[X, fY] = f[X, Y] + \mathcal{L}_X(f)Y.$$

We have seen that one incarnation of a Poisson structure π on a manifold M is the Lie bracket from Proposition 2.11 on the space of 1-forms $\Omega^1(M)$:

$$[\alpha, \beta]_\pi := \mathcal{L}_{\pi^\# \alpha}(\beta) - \mathcal{L}_{\pi^\# \beta}(\alpha) - d(\pi(\alpha, \beta)).$$

Also this Lie bracket satisfies a Leibniz-type identity

$$[\alpha, f\beta]_\pi = f[\alpha, \beta]_\pi + \mathcal{L}_{\pi^\# \alpha}(f)\beta.$$

The striking similarities between these two operations beg for a deeper understanding. This is the starting point of a new view/philosophy on Poisson geometry, dual to the classical one, where the tangent bundle is replaced by the cotangent bundle. The conceptual framework is provided by the theory of Lie algebroids.

Definition 9.1. A **Lie algebroid** over a manifold M consists of a vector bundle $A \rightarrow M$, a Lie algebra structure $[\cdot, \cdot]_A$ on the space of sections $\Gamma(A)$, and a vector bundle map $\rho : A \rightarrow TM$ satisfying the Leibniz identity

$$[\alpha, f\beta]_A = f[\alpha, \beta]_A + \mathcal{L}_{\rho(\alpha)}(f)\beta, \quad \forall \alpha, \beta \in \Gamma(A), f \in C^\infty(M).$$

One should think of a Lie algebroid A as “the correct tangent bundle” for some geometry present on the base manifold M . The map $\rho : A \rightarrow TM$, called the **anchor map**, relates this new tangent bundle back to the classical tangent bundle: its image is made of “the relevant tangent directions”. The following consequence of the definition makes this connection more precise:

Proposition 9.2. *Let $(A, [\cdot, \cdot]_A, \rho)$ be a Lie algebroid. Then*

$$\rho([\alpha, \beta]_A) = [\rho(\alpha), \rho(\beta)], \quad \forall \alpha, \beta \in \Gamma(A).$$

Proof. Consider the Jacobiator

$$J(\alpha, \beta, \gamma) := [[\alpha, \beta]_A, \gamma]_A + [[\beta, \gamma]_A, \alpha]_A + [[\gamma, \alpha]_A, \beta]_A.$$

Using only the Leibniz identity, \mathbb{R} -bilinearity, and skew-symmetry, we find that for any $\alpha, \beta, \gamma \in \Gamma(A)$ and function $f \in C^\infty(M)$, we have

$$J(\alpha, \beta, f\gamma) - fJ(\alpha, \beta, \gamma) = \mathcal{L}_{\rho([\alpha, \beta]_A) - [\rho(\alpha), \rho(\beta)]}(f)\gamma.$$

Since $[\cdot, \cdot]_A$ satisfies Jacobi, the left side is zero, and the result follows. \square

Example 9.3 (Tangent bundles). For any manifold M , the tangent bundle $A = TM$ is a Lie algebroid for the usual Lie bracket of vector fields and with anchor the identity map. 

Example 9.4 (Cotangent bundles of Poisson manifolds). As seen in Proposition 2.11, for any Poisson manifold (M, π) , the cotangent bundle $A = T^*M$ is a Lie algebroid with Lie bracket $[\cdot, \cdot]_\pi$ and anchor $\pi^\# : T^*M \rightarrow TM$. 

Exercise 9.5. Let $(T^*M, [\cdot, \cdot], \rho)$ be a Lie algebroid structure on the cotangent bundle of a manifold M that satisfies the following two properties:

- (i) The anchor is skew-symmetric: $\rho = -\rho^*$.
- (ii) The brackets of any two closed 1-forms is a closed 1-form:

$$[\Omega_{\text{cl}}^1(M), \Omega_{\text{cl}}^1(M)] \subset \Omega_{\text{cl}}^1(M).$$

Show that there exists a unique Poisson structure $\pi \in \mathfrak{X}^2(M)$ on M such that this Lie algebroid coincides with the cotangent Lie algebroid $(T^*M, [\cdot, \cdot]_\pi, \pi^\#)$.

Example 9.6 (Coisotropic submanifolds). Any coisotropic submanifold C of (M, π) gives rise to a Lie algebroid structure on the conormal bundle $\nu^*(C) := (TC)^\circ$. Indeed, the coisotropic condition implies that $\pi^\#$ gives a bundle map $\pi^\# : \nu^*(C) \rightarrow TC$ and this will be the anchor map. The bracket on $\Gamma(\nu^*(C))$ is induced by the Lie bracket $[\cdot, \cdot]_\pi$. We leave the details to the reader. 

Example 9.7 (Foliations). An involutive distribution $D \subset TM$ defines a Lie algebroid with bundle $A = D$, anchor the inclusion $\rho : D \hookrightarrow TM$, and Lie bracket the usual Lie bracket of vector fields. Note that sections of A are just vector fields tangent to the corresponding foliation. 

Example 9.8 (Lie algebras). A Lie algebra \mathfrak{g} is the same thing as a Lie algebroid $A \rightarrow M$ whose base manifold is a singleton: $M = \{*\}$. 

Example 9.9 (Action Lie algebroids). A Lie algebra action $\mathfrak{a} : \mathfrak{g} \rightarrow \mathfrak{X}(M)$ gives rise to the **action Lie algebroid**. The vector bundle $A \rightarrow M$ is the trivial vector bundle with fiber \mathfrak{g} , the anchor is given by

$$\rho : M \times \mathfrak{g} \rightarrow TM, \quad (x, v) \mapsto \mathfrak{a}(v)_x,$$

and the Lie bracket on the space of sections $\Gamma(A) \simeq C^\infty(M; \mathfrak{g})$ is defined by

$$[f, g](x) = [f(x), g(x)]_{\mathfrak{g}} + (\mathcal{L}_{\mathfrak{a}(f(x))}g)(x) - (\mathcal{L}_{\mathfrak{a}(g(x))}f)(x). \quad \img alt="fish icon" data-bbox="825 330 855 345"/>$$

Example 9.10 (Dirac structures). A Dirac structure $\mathbb{L} \subset TM$ is a Lie algebroid with Lie bracket the restriction of the Dorfman bracket,

$$[X + \alpha, Y + \beta]_{\mathbb{L}} := [X, Y] + \mathcal{L}_X\beta - \text{di}_Y\alpha,$$

and with anchor the restriction of the projection on TM ,

$$\rho(X + \alpha) := X. \quad \img alt="fish icon" data-bbox="825 495 855 510"/>$$

You probably have noticed that in all these examples the base M of the Lie algebroid $(A, [\cdot, \cdot]_A, \rho)$ has a (singular) foliation with the property that it “integrates” the (singular) distribution

$$\text{Im } \rho \subset TM.$$

This is a general fact about Lie algebroids, as we will see in Chapter 13. There we will study in more depth Lie algebroids as well as their global counterparts, called Lie groupoids.

For now, we observe that many of the constructions from classical differential geometry can be formulated in terms of vector fields and Lie brackets, and so they have obvious generalizations to Lie algebroids. Examples of these constructions include the de Rham differential, the Lie derivative, the covariant derivative, flows, etc.

In the rest of this chapter we will explore the cotangent Lie algebroid of a Poisson manifold, and we will mention Lie algebroids only in passing. However, the reader should keep in mind this conceptual framework and even try to guess how a given construction extends to the general setting of Lie algebroids. When we come back to Lie algebroids in Chapter 13, the reader will be able to check their guess.

9.2. The Poisson differential and Poisson cohomology

Following the credo that the right “tangent bundle” of a Poisson manifold is its cotangent Lie algebroid, we mimic the well-known formula for the de Rham differential:

Definition 9.11. Let (M, π) be a Poisson manifold. The **Poisson differential** is the linear map $d_\pi : \mathfrak{X}^k(M) \rightarrow \mathfrak{X}^{k+1}(M)$ given by

$$(9.1) \quad d_\pi \vartheta(\alpha_0, \dots, \alpha_k) = \sum_{i=0}^k (-1)^i \mathcal{L}_{\pi^\#(\alpha_i)}(\vartheta(\alpha_0, \dots, \widehat{\alpha}_i, \dots, \alpha_k)) \\ + \sum_{0 \leq i < j \leq k} (-1)^{i+j} \vartheta([\alpha_i, \alpha_j]_\pi, \alpha_0, \dots, \widehat{\alpha}_i, \dots, \widehat{\alpha}_j, \dots, \alpha_k).$$

Exercise 9.12. Show that the Poisson differential $d_\pi : \mathfrak{X}^k(M) \rightarrow \mathfrak{X}^{k+1}(M)$ is given in terms of the Schouten bracket by

$$d_\pi \vartheta = [\pi, \vartheta].$$

Using this exercise and the properties of the Schouten bracket, we find

$$d_\pi^2 \vartheta = [\pi, [\pi, \vartheta]] = 2[[\pi, \pi], \vartheta] = 0,$$

so d_π is indeed a differential and it has an associated cohomology:

Definition 9.13. The **Poisson cohomology** of a Poisson manifold (M, π) is the cohomology of the cochain complex $(\mathfrak{X}^\bullet(M), d_\pi)$:

$$H_\pi^k(M) := \frac{\text{Ker}(d_\pi : \mathfrak{X}^k(M) \rightarrow \mathfrak{X}^{k+1}(M))}{\text{Im}(d_\pi : \mathfrak{X}^{k-1}(M) \rightarrow \mathfrak{X}^k(M))}.$$

For the algebraic structure on the Poisson cohomology, we use the basic properties of the Schouten bracket (see Theorem 2.8) to find that d_π satisfies the following:

- The graded Leibniz identity with respect to the wedge product: for all $\vartheta_1 \in \mathfrak{X}^p(M)$, $\vartheta_2 \in \mathfrak{X}^q(M)$,

$$d_\pi(\vartheta_1 \wedge \vartheta_2) = d_\pi \vartheta_1 \wedge \vartheta_2 + (-1)^p \vartheta_1 \wedge d_\pi \vartheta_2.$$

- The graded Leibniz identity with respect to the Schouten bracket: for all $\vartheta_1 \in \mathfrak{X}^{k+1}(M)$, $\vartheta_2 \in \mathfrak{X}^{l+1}(M)$,

$$d_\pi[\vartheta_1, \vartheta_2] = [d_\pi \vartheta_1, \vartheta_2] + (-1)^k [\vartheta_1, d_\pi \vartheta_2].$$

These equations imply that the algebraic operations descend to cohomology:

Proposition 9.14. *The wedge product and the Schouten bracket on multi-vector fields induce operations in cohomology:*

$$H_\pi^p(M) \times H_\pi^q(M) \rightarrow H_\pi^{p+q}(M), \quad \overline{\vartheta_1} \wedge \overline{\vartheta_2} := \overline{\vartheta_1 \wedge \vartheta_2},$$

$$H_\pi^{k+1}(M) \times H_\pi^{l+1}(M) \rightarrow H_\pi^{k+l+1}(M), \quad [\overline{\vartheta_1}, \overline{\vartheta_2}] := \overline{[\vartheta_1, \vartheta_2]},$$

where $\overline{\vartheta}$ denotes the image of ϑ in cohomology. In particular,

$$H_\pi^\bullet(M) := \bigoplus_p H_\pi^p(M)$$

becomes both a graded commutative algebra, as well as (up to a degree shift $p = k + 1$) a graded Lie algebra, and the two operations are related by the graded Leibniz identity as in (iv) of Theorem 2.8.

The similarities between de Rham cohomology and Poisson cohomology are mostly at a superficial level, as there are many aspects which make these theories quite different. For example, a general Poisson map $\Phi : (M, \pi_M) \rightarrow (N, \pi_N)$ does not induce an obvious map between the Poisson cohomologies of M and of N . If we think in terms of “generalized tangent bundles”, i.e., the cotangent Lie algebroids, the reason is clear: in general, such a map *does not* induce a bundle map $T^*M \rightarrow T^*N$ covering $\Phi : M \rightarrow N$. This is one of the issues that makes computations of Poisson cohomology very hard in most examples.

9.3. Low degrees

We now look at Poisson cohomology in low degrees, unraveling its geometric content and exhibiting several interesting cohomology classes. We first note that, as a consequence of Proposition 9.14,

- $H_\pi^0(M)$ is a ring and each $H_\pi^p(M)$ is a module over it.
- $H_\pi^1(M)$ is a Lie algebra and each $H_\pi^p(M)$ is a representation of it.

Degree 0. In degree 0, Poisson cohomology is just the space of Casimirs

$$H_\pi^0(M) = \{f \in C^\infty(M) : \{f, g\} = 0 \ \forall g \in C^\infty(M)\}.$$

Indeed, for $k = 0$, d_π becomes

$$d_\pi : \mathfrak{X}^0(M) = C^\infty(M) \rightarrow \mathfrak{X}(M), \quad f \mapsto [\pi, f] = -X_f.$$

The fact that $H_\pi^0(M)$ is a ring amounts to the remark that the product of two Casimirs is again a Casimir. Note that, unlike de Rham cohomology, this space is typically infinite dimensional. Since $H_\pi^k(M)$ is a module over $H_\pi^0(M)$, the higher degree Poisson cohomology groups are typically also infinite dimensional.

Degree 1. The degree 1 Poisson cohomology is the Lie algebra

$$H_\pi^1(M) := \frac{\text{Poisson vector fields}}{\text{Hamiltonian vector fields}} = \frac{\mathfrak{X}(M, \pi)}{\mathfrak{X}_{\text{Ham}}(M, \pi)}.$$

This follows immediately from the expression above for the differential in degree 0, and the fact that in degree 1 the differential is

$$d_\pi : \mathfrak{X}^1(M) = \mathfrak{X}(M) \rightarrow \mathfrak{X}^2(M), \quad X \mapsto [\pi, X] = -\mathcal{L}_X \pi.$$

Therefore, $H_\pi^1(M)$ measures the difference between Poisson vector fields and Hamiltonian vector fields. The Lie algebra structure on $H_\pi^1(M)$ is inherited from the Lie algebra of Poisson vector fields — recall from Exercise 1.10 that it has the Hamiltonian vector fields as a Lie algebra ideal. One can also say that $H_\pi^1(M)$ is the Lie algebra of infinitesimal outer automorphisms of $(C^\infty(M), \{\cdot, \cdot\})$.

A natural and important degree 1 Poisson cohomology class arises when looking for volume forms

$$\mu \in \Omega^{\text{top}}(M)$$

which are invariant under all Hamiltonian diffeomorphisms, i.e., that satisfy

$$\mathcal{L}_{X_f} \mu = 0, \quad \forall f \in C^\infty(M).$$

For a symplectic manifold (M, ω) such a volume form always exists, namely the Liouville volume form

$$\mu := \frac{\omega^m}{m!} \quad (2m = \dim(M)).$$

However, a general Poisson manifold (M, π) need not be orientable, and even if it is orientable, such volume forms do not always exist. Assuming orientability, we choose a volume form μ . If X_f is a Hamiltonian vector field, then $\mathcal{L}_{X_f} \mu$ is also a top degree form; hence

$$\mathcal{L}_{X_f} \mu = X_\mu(f) \mu,$$

for some function $X_\mu(f) \in C^\infty(M)$.

Lemma 9.15. *The map $f \mapsto X_\mu(f)$ is a derivation of $C^\infty(M)$; hence it defines a vector field X_μ . Moreover, one has the following:*

- (i) X_μ is a Poisson vector field.
- (ii) If $\mu' = \pm e^g \mu$ is some other volume form, then the vector fields $X_{\mu'}$ and X_μ differ by a Hamiltonian vector field: $X_{\mu'} = X_\mu - X_g$.

We leave the proof as an exercise. We call the Poisson vector field X_μ the **modular vector field** of (M, π) relative to the volume form μ . It follows from this lemma that the class $[X_\mu] \in H_\pi^1(M)$ is well-defined and independent of the choice of volume form.

Definition 9.16. The **modular class** of an orientable Poisson manifold (M, π) is the Poisson cohomology class

$$\text{mod}(M, \pi) := [X_\mu] \in H_\pi^1(M).$$

We say that (M, π) is **unimodular** if $\text{mod}(M, \pi) = 0$.

Corollary 9.17. *A Poisson manifold (M, π) has an invariant volume form if and only if it is unimodular.*

Proof. If μ is an invariant volume form, then the definition of the modular vector field shows that $X_\mu = 0$, so $\text{mod}(M, \pi) = [X_\mu] = 0$. Conversely, if $\text{mod}(M, \pi) = 0$, choose some volume form μ . Then $X_\mu = X_g$ for some function g , so if we let $\mu' = e^g \mu$, the lemma shows that

$$X_{\mu'} = X_\mu - X_g = 0.$$

Hence, μ' is an invariant volume form. □

Example 9.18. For the linear Poisson structure on \mathbb{R}^2 given by

$$\{x, y\} = x,$$

the modular vector field associated with the volume form $\mu = dx \wedge dy$ is

$$X_\mu = -\frac{\partial}{\partial y}.$$

This vector field is not Hamiltonian, since it does not vanish along $x = 0$. Hence, this Poisson structure is not unimodular. 

Exercise 9.19. A Lie algebra \mathfrak{g} is called unimodular if $\text{tr}(\text{ad}_v) = 0$ for all $v \in \mathfrak{g}$. Show that \mathfrak{g} is unimodular if and only if its dual \mathfrak{g}^* is a unimodular Poisson manifold.

Example 9.20. Generalizing Example 9.18, consider an orientable log-symplectic Poisson manifold (M^{2n}, π) , with nonempty singular locus $Z = (\bigwedge^n \pi)^{-1}(0)$. Fix a volume form $\mu \in \Omega^{2n}(M)$. Define the smooth function

$$u := \left\langle \bigwedge^n \pi, \mu \right\rangle \in C^\infty(M).$$

By the defining property of a log-symplectic structure, 0 is a regular value of u and $Z = u^{-1}(0)$. Taking the derivative of u along a Hamiltonian vector field X_f in the above equation and using that $\mathcal{L}_{X_f} \pi = 0$, we obtain

$$\{f, u\} = \left\langle \bigwedge^n \pi, X_\mu(f)\mu \right\rangle = X_\mu(f)u.$$

Therefore, on $M \setminus Z$, the modular vector field is Hamiltonian:

$$X_\mu(f) = -\frac{1}{u} \{u, f\} = -\{\log |u|, f\} = -X_{\log |u|}(f).$$

This was clear because π is nondegenerate on $M \setminus Z$. Note that the vector field $X_{\log|u|}$ has appeared in the proof of Proposition 4.21, where we already observed that it extends smoothly to Z , although $\log|u| \in C^\infty(M \setminus Z)$ does not extend smoothly to $Z = \{u = 0\}$. Since the Poisson structure is nondegenerate almost everywhere, the Hamiltonian vector field is determined up to a constant, and since μ was arbitrary, we conclude that (M, π) is not unimodular unless $Z = \emptyset$. 

Example 9.21. Let (M, π) be a 3-dimensional Poisson manifold with a volume form μ . Recall from Subsection 2.4.4 that the Poisson structure is encoded by the completely integrable 1-form $\theta := i_\pi \mu$. The modular vector field of (M, π) corresponding to μ is given by

$$i_{X_\mu} \mu = d\theta.$$

So if θ is closed, then (M, π) is unimodular. Conversely, if (M, π) is unimodular, then we can choose a volume form μ such that $X_\mu = 0$. The above equation implies that the completely integrable 1-form corresponding to μ is closed. 

Exercise 9.22. Show that a corank 1 Poisson manifold (M, π) is unimodular if and only if the symplectic foliation is induced by a closed 1-form.

Degree 2. In degree 2 the Poisson differential is the map

$$d_\pi : \mathfrak{X}^2(M) \rightarrow \mathfrak{X}^3(M), \quad \vartheta \mapsto [\pi, \vartheta],$$

so the second Poisson cohomology is the space

$$H_\pi^2(M) := \frac{\{\vartheta \in \mathfrak{X}^2(M) : [\pi, \vartheta] = 0\}}{\{\mathcal{L}_X \pi : X \in \mathfrak{X}(M)\}}.$$

Example 9.23. The Poisson bivector itself induces a cohomology class

$$[\pi] \in H_\pi^2(M),$$

called the **fundamental class** of the Poisson manifold. In the same way that symplectic structures are rarely exact — they are never exact on compact manifolds — this class is nonzero in general. One says that (M, π) is an **exact Poisson manifold** when $[\pi] = 0$. 

Exercise 9.24. Show that any linear Poisson structure is exact.

Next, we relate $H_\pi^2(M)$ to deformations of the Poisson structure.

Definition 9.25. A **deformation of a Poisson structure** π on M is a family $\{\pi_t\}_{t \in I}$ of Poisson bivectors on M , depending smoothly on t in an interval I containing 0 and such that $\pi_0 = \pi$.

The **variation** of a deformation $\{\pi_t\}_{t \in I}$ at $t = 0$ is the bivector field

$$(9.2) \quad \vartheta := \left. \frac{d}{dt} \right|_{t=0} \pi_t.$$

Differentiating the Poisson equation $[\pi_t, \pi_t] = 0$ at $t = 0$, one finds

$$0 = \left. \frac{d}{dt} \right|_{t=0} [\pi_t, \pi_t] = 2[\pi, \vartheta] = 2d_\pi \vartheta.$$

This suggests that one should think of elements $\vartheta \in \mathfrak{X}^2(M)$ with $d_\pi \vartheta = 0$ as giving “infinitesimal deformations” of π .

We will say that two deformations $\{\pi_t\}_{t \in I}$ and $\{\pi'_t\}_{t \in I}$ of the Poisson structure π are **equivalent deformations** if there exists a smooth family $\{\phi^t\}_{t \in I}$ of diffeomorphisms of M with $\phi^0 = \text{Id}$ and such that

$$(9.3) \quad \pi'_t = (\phi^t)^*(\pi_t).$$

The starting velocity of the family $\{\phi^t\}_{t \in I}$ is the vector field $X \in \mathfrak{X}(M)$,

$$X_x = \left. \frac{d}{dt} \right|_{t=0} \phi^t(x).$$

Differentiating equation (9.3), one finds that the variations ϑ' and ϑ of the two deformations are in the same cohomology class:

$$\vartheta' - \vartheta = \mathcal{L}_X \pi = -d_\pi X.$$

Therefore, the second Poisson cohomology space can be interpreted as the space of infinitesimal deformations of π modulo equivalence. A more precise statement is the following:

Proposition 9.26. *The variation at $t = 0$ (see (9.2)) of any deformation $\{\pi_t\}_{t \in I}$ of (M, π) defines a cohomology class*

$$[\vartheta] \in H_\pi^2(M)$$

which depends only of the equivalence class of the deformation.

Example 9.27. Let (M, π) be a Poisson manifold. Then $\pi_t := e^t \pi$ is a deformation of π with variation the fundamental class $[\pi] \in H_\pi^2(M)$. This class vanishes if and only if there is vector field X such that $\mathcal{L}_X \pi = \pi$. If X is complete, then its flow gives an equivalence between π_t and the constant deformation:

$$e^t \pi = (\phi_X^t)^* \pi. \quad \text{🐟}$$

Does any element in $H_\pi^2(M)$ arise from a deformation? The answer, in general, is no. The extra structure on the Poisson cohomology, namely the graded Lie bracket, can be used to describe an obstruction:

Exercise 9.28. Let (M, π) be a Poisson manifold. Show that if a class $c \in H_\pi^2(M)$ is induced by a deformation of π , then $[c, c] = 0 \in H_\pi^3(M)$.

Remark 9.29 (Moduli space of Poisson structures). One may define the moduli space \mathcal{M} of Poisson structures on a manifold M by considering the space of all Poisson bivectors on M and identifying two Poisson bivector fields whenever they are related via some diffeomorphism. A deformation π_t of a Poisson structure π induces a curve in the moduli space through the class $[\pi] \in \mathcal{M}$. Two equivalent deformations define the same curve in \mathcal{M} , and we can think of the second Poisson cohomology of π as the (formal) tangent space to the moduli space at $[\pi]$:

$$T_{[\pi]}\mathcal{M} = H_{\pi}^2(M).$$

In general, this is only a formal statement: the space \mathcal{M} can be quite pathological and can fail to have even the structure of a Fréchet manifold.

9.4. Shadows of Poisson cohomology

We stress that, in general, finding the Poisson cohomology of a given Poisson manifold is an almost impossible task, as the available techniques apply only to particular classes of structures. Still, we can often relate it to other cohomologies, which are easier to compute, and these provide geometric insight into Poisson cohomology.

Proposition 9.30. *Given a Poisson manifold (M, π) , the map*

$$\rho^* : \Omega^k(M) \rightarrow \mathfrak{X}^k(M), \quad (\rho^*\omega)(\alpha_1, \dots, \alpha_k) := \omega(\pi^{\sharp}(\alpha_1), \dots, \pi^{\sharp}(\alpha_k)),$$

defines a morphism of complexes $\rho^ : (\Omega^k(M), d) \rightarrow (\mathfrak{X}^k(M), d_{\pi})$ and induces a morphism of graded rings*

$$\rho^* : H^{\bullet}(M) \rightarrow H_{\pi}^{\bullet}(M).$$

Before we give the proof let us look at two extreme examples.

Example 9.31 (Symplectic structures). In particular, for nondegenerate Poisson structures π^{\sharp} is an isomorphism and so Poisson cohomology is isomorphic to the de Rham cohomology. Hence, in the symplectic case, the geometric interpretations in small degrees give the following:

- $H_{\pi}^0(M) = H^0(M) = \mathbb{R}$ if M is connected; the only Casimir functions are the constant functions.
- $H_{\pi}^1(M) = H^1(M)$ so the infinitesimal outer Poisson (= symplectic) automorphisms are the cohomology classes of closed 1-forms.
- $H_{\pi}^2(M) = H^2(M)$ so infinitesimal deformations of a symplectic structure are in 1-to-1 correspondence with second cohomology classes. In this case, infinitesimal deformations are not obstructed: for $\eta \in \Omega_{\text{cl}}^2(M)$, $\omega + t\eta$ is symplectic for small t . This is related to the fact that the induced Lie bracket on cohomology is trivial. 

Example 9.32 (The zero Poisson structure). In general the map from Proposition 9.30, $\rho^* : H^\bullet(M) \rightarrow H_\pi^\bullet(M)$, is far from being an isomorphism. For the zero Poisson structure $(M, \pi \equiv 0)$,

$$H_\pi^k(M) = \mathfrak{X}^k(M),$$

which is always an infinite-dimensional vector space (if $\dim M > 0$). This contrasts with $H^k(M)$ which is finite dimensional if, for example, M is compact. Although $H_\pi^k(M)$ is infinite dimensional, it is a *finitely generated* module over the space of Casimirs $H_\pi^0(M)$. This is a more typical situation, although there are examples where even this does not hold. 

Proof of Proposition 9.30. Recall the Koszul-type formula for the de Rham differential, $d : \Omega^k(M) \rightarrow \Omega^{k+1}(M)$,

$$(9.4) \quad \begin{aligned} d\omega(X_0, \dots, X_k) &= \sum_{i=0}^k (-1)^i \mathcal{L}_{X_i}(\omega(X_0, \dots, \widehat{X}_i, \dots, X_k)) \\ &+ \sum_{0 \leq i < j \leq k} (-1)^{i+j} \omega([X_i, X_j], X_0, \dots, \widehat{X}_i, \dots, \widehat{X}_j, \dots, X_k). \end{aligned}$$

Comparing this formula with the formula for the Poisson differential (9.1), and observing that π^\sharp sends the Lie bracket of 1-forms to the Lie bracket of vector fields, it follows immediately that $\rho^* : (\Omega^k(M), d) \rightarrow (\mathfrak{X}^k(M), d_\pi)$ is a map of complexes.

On the other hand, ρ^* is induced by the bundle map

$$\bigwedge^k (-\pi)^\sharp : \bigwedge^k T^*M \rightarrow \bigwedge^k TM.$$

This map clearly preserves the ring structure, so the result follows. □

Formula (9.1) for the Poisson differential and the proof of Proposition 9.30 show that there is an algebroid-theoretic content underlying our discussion. First of all, since (9.1) makes use only of π^\sharp and $[\cdot, \cdot]_\pi$, we see that it applies to any Lie algebroid. More precisely, for a Lie algebroid $(A, [\cdot, \cdot]_A, \rho)$ over M , the A -de Rham complex consists of **A -forms**

$$\Omega^\bullet(A) := \Gamma\left(\bigwedge^\bullet A^*\right),$$

together with the **A -differential** $d_A : \Omega^\bullet(A) \rightarrow \Omega^{\bullet+1}(A)$ defined by

$$\begin{aligned} d_A\omega(s_0, \dots, s_k) &= \sum_{i=0}^k (-1)^i \mathcal{L}_{\rho(s_i)}(\omega(s_0, \dots, \widehat{s}_i, \dots, s_k)) \\ &+ \sum_{0 \leq i < j \leq k} (-1)^{i+j} \omega([s_i, s_j]_A, s_0, \dots, \widehat{s}_i, \dots, \widehat{s}_j, \dots, s_k). \end{aligned}$$

The resulting **Lie algebroid cohomology** will be denoted $H^\bullet(A)$. Some basic examples follow:

- For $A = TM$, one recovers ordinary differential forms, the exterior derivative, and de Rham cohomology.
- For $A = T^*M$ the cotangent bundle of a Poisson manifold (M, π) , one obtains multivector fields, the Poisson differential, and Poisson cohomology.
- For $A = T\mathcal{F}$ the tangent bundle of a foliation \mathcal{F} , one recovers foliated forms and foliated cohomology (see Section C.2).
- For $A = \mathfrak{g}$ a Lie algebra, one obtains the Chevalley-Eilenberg differential and Lie algebra cohomology (see Section A.1).

For many classes of Poisson manifolds one can use similar arguments to relate Poisson cohomology to other more amenable cohomologies.

Example 9.33 (Linear Poisson structures). The Poisson cohomology of a linear Poisson structure $(\mathfrak{g}^*, \pi \equiv \pi_{\mathfrak{g}})$ can be expressed in terms of Lie algebra cohomology with coefficients:

$$H_{\pi}^k(\mathfrak{g}^*) = H^k(\mathfrak{g}, C^{\infty}(\mathfrak{g}^*)).$$

Here $C^{\infty}(\mathfrak{g}^*)$ is the infinite-dimensional representation of \mathfrak{g} induced by the coadjoint action or, in terms of the Poisson structure,

$$\rho : \mathfrak{g} \rightarrow \mathfrak{gl}(C^{\infty}(\mathfrak{g}^*)), \quad v \mapsto \mathcal{L}_{X_v},$$

where X_v is the Hamiltonian vector field of the linear function $v : \mathfrak{g}^* \rightarrow \mathbb{R}$.

To prove this, observe that a multivector field $\vartheta \in \mathfrak{X}^k(\mathfrak{g}^*)$ can be viewed as an alternating multilinear map

$$c_{\vartheta} : \bigwedge^k \mathfrak{g} \rightarrow C^{\infty}(\mathfrak{g}^*), \quad c_{\vartheta}(v_1, \dots, v_k) := \vartheta(v_1, \dots, v_k),$$

where on the right-hand side we identify an element $v \in \mathfrak{g}$ with a constant 1-form $v \in \Omega^1(\mathfrak{g}^*)$. This gives an isomorphism of complexes

$$(\mathfrak{X}^\bullet(\mathfrak{g}^*), d_{\pi}) \rightarrow \left(\bigwedge^{\bullet} \mathfrak{g}^* \otimes C^{\infty}(\mathfrak{g}^*), d_{\mathfrak{g}} \right), \quad \vartheta \mapsto c_{\vartheta},$$

and the result follows.

The Casimir functions are the space of ad^* -invariant functions on \mathfrak{g}^* :

$$H_{\pi}^0(\mathfrak{g}^*) = \text{Inv}(\mathfrak{g}^*).$$

One has the following:

Theorem 9.34 (Ginzburg and Weinstein). *For any compact Lie algebra \mathfrak{g} ,*

$$(9.5) \quad H_{\pi}^k(\mathfrak{g}^*) \simeq H^k(\mathfrak{g}) \otimes \text{Inv}(\mathfrak{g}^*).$$

This is proven in [80]. In this case, note that $H_\pi^\bullet(\mathfrak{g}^*)$ is a finite-dimensional $H_\pi^0(\mathfrak{g}^*)$ -module — this fails for arbitrary Lie algebras, even semisimple ones. Actually, the Poisson cohomology is not known for general semisimple Lie algebras. 

Example 9.35 (Regular Poisson structures). The Poisson cohomology of a regular Poisson structure can be quite complicated. In order to understand why, consider first the case of a product $(M, \pi) = (S, \omega) \times (N, 0)$, where (S, ω) is a symplectic manifold. Assuming that S is compact, an argument similar to the symplectic case (9.31) implies that

$$(9.6) \quad H_\pi^k(M) \simeq \bigoplus_{q=0}^k H^q(S) \otimes \mathfrak{X}^{k-q}(N).$$

In particular, this is a finitely generated module over $H_\pi^0(M) = C^\infty(N)$. If one replaces the constant symplectic structure by a family of symplectic structures $\{\omega_x\}_{x \in N}$ on S , the outcome is much more complicated.

For a general regular Poisson manifold (M, π) one can choose a subbundle complementary to the symplectic foliation

$$TM = T\mathcal{F}_\pi \oplus E,$$

giving a decomposition of the space of multivector fields

$$\mathfrak{X}^k(M) = \bigoplus_{p+q=k} \mathfrak{X}^{p,q}(M) \quad \text{with} \quad \mathfrak{X}^{p,q}(M) := \Gamma\left(\bigwedge^p T\mathcal{F}_\pi \otimes \bigwedge^q E\right).$$

Because $\pi \in \mathfrak{X}^{2,0}(M)$ the differential $d_\pi = [\pi, -]$ decomposes as

$$d_\pi = d_{(1,0)} + d_{(2,-1)},$$

with

$$d_{(1,0)} : \mathfrak{X}^{p,q}(M) \rightarrow \mathfrak{X}^{p+1,q}(M), \quad d_{(2,-1)} : \mathfrak{X}^{p,q}(M) \rightarrow \mathfrak{X}^{p+2,q-1}(M).$$

By the usual tools of cohomological algebra — the spectral sequence associated to a filtration — one obtains (see [114, 139, 143]):

Theorem 9.36 (Vaisman). *For the Poisson cohomology of a regular Poisson manifold (M, π) there exists a convergent spectral sequence*

$$E_2^{p,q} = H^p\left(\mathcal{F}_\pi, \bigwedge^q \nu(\mathcal{F}_\pi)\right) \Rightarrow H_\pi^{p+q}(M)$$

where $H^p(\mathcal{F}_\pi, \bigwedge^q \nu(\mathcal{F}_\pi))$ is the foliated cohomology of \mathcal{F}_π with coefficients in the exterior powers of the normal bundle $\nu(\mathcal{F}_\pi) = TM/T\mathcal{F}_\pi$, endowed with the Bott connection. 

Example 9.37 (Log-symplectic structures). For log-symplectic structures the Poisson cohomology can be found explicitly:

Theorem 9.38 (Mărcuț and Osorno-Torres). *For a log-symplectic manifold (M, π) with singular locus $Z \subset M$, the Poisson cohomology can be expressed in terms of de Rham cohomology:*

$$(9.7) \quad H_{\pi}^k(M) \simeq H^k(M) \oplus H^{k-1}(Z).$$

The proof can be found in [125]. Here we explain how to build this isomorphism when M orientable.

Consider a tubular neighborhood $E \subset M$ of Z in M , and denote by $\text{pr}_E : E \rightarrow Z$ the bundle projection. Let μ be a volume form on M . As in Example 9.20 consider the function

$$u := \left\langle \bigwedge^n \pi, \mu \right\rangle \in C^{\infty}(M).$$

By modifying μ by a positive function, we may assume that $|u| = 1$ on $M \setminus U$, for some open set U with $Z \subset U \subset \overline{U} \subset E$. Using the map from Proposition 9.30, we define the cochain map

$$(\Omega^{\bullet}(M) \oplus \Omega^{\bullet-1}(Z), d \oplus d) \rightarrow (\mathfrak{X}^{\bullet}(M), d_{\pi})$$

by setting

$$(9.8) \quad (\alpha, \beta) \mapsto \rho^*(\alpha + d \log |u| \wedge \text{pr}_E^* \beta) = \rho^*(\alpha) + X_{\mu} \wedge \rho^*(\text{pr}_E^* \beta),$$

where, as in Example 9.20, the modular vector field of μ is

$$X_{\mu} = -X_{\log |u|} = \rho^*(d \log |u|)$$

and $X_{\mu} \wedge \rho^*(\text{pr}_E^* \beta)$ is extended by 0 outside of E . The condition on u ensures that the extension is smooth. One can show that the map induced by (9.8) in cohomology does not depend on the choices and is an isomorphism. 

One can also exploit the algebroid-theoretical nature of the cohomology to achieve functoriality which, as pointed out before, does not work for Poisson maps. First of all, a morphism $\Phi : A \rightarrow B$ between two Lie algebroids over the same base M is a bundle map preserving anchors and brackets. Such a map induces a pullback map between the associated complexes and therefore also in cohomology:

$$\Phi^* : H^{\bullet}(B) \rightarrow H^{\bullet}(A).$$

This is precisely what we did in the proof of Proposition 9.30 for the Lie algebroid morphism $\Phi = \pi^{\sharp} : T^*M \rightarrow TM$. More generally, the same argument shows that, for any Lie algebroid $(A, [\cdot, \cdot]_A, \rho)$, one has a map

$$\rho^* : H^{\bullet}(M) \rightarrow H^{\bullet}(A).$$

Functoriality also holds for morphisms of algebroids over different bases. However, this notion of morphism is more subtle since such a map does not induce a map at the level of sections. However, note that any vector bundle map $\Phi : A \rightarrow B$ induces a pullback map taking B -forms to A -forms.

Definition 9.39. Let $(A, [\cdot, \cdot]_A, \rho_A)$ and $(B, [\cdot, \cdot]_B, \rho_B)$ be Lie algebroids. A vector bundle map $\Phi : A \rightarrow B$ is called a **Lie algebroid morphism** if the pullback along Φ commutes with the differentials:

$$\Phi^* : \Omega^k(B) \rightarrow \Omega^k(A), \quad \Phi^* d_B = d_A \Phi^*.$$

Exercise 9.40. Show that a vector bundle map $\Phi : A \rightarrow B$ covering a diffeomorphism $\phi : M \rightarrow N$ is a Lie algebroid morphism if and only if the following hold:

- (i) Φ preserves anchors: $\rho_B \circ \Phi = d\phi \circ \rho_A$.
- (ii) Φ preserves brackets:

$$[\Phi_*(\alpha), \Phi_*(\beta)]_B = \Phi_*([\alpha, \beta]_A),$$

for all $\alpha, \beta \in \Gamma(A)$, where $\Phi_*(\alpha) := \Phi \circ \alpha \circ \phi^{-1}$.

For example, the inclusion of the isotropy Lie algebra \mathfrak{g}_x of a Poisson manifold (M, π) in its cotangent algebroid,

$$i_x : \mathfrak{g}_x \hookrightarrow T^*M,$$

is a Lie algebroid map. Hence we obtain a restriction map in cohomology:

$$(9.9) \quad i_x^* : H_\pi^\bullet(M) \rightarrow H^\bullet(\mathfrak{g}_x).$$

This allows one to pass from the (complicated) Poisson cohomology to the (simpler) Lie algebra cohomology. Even more, this can be used to find obstructions for a Poisson cohomology class to arise from a de Rham cohomology class:

Exercise 9.41. For $k > 0$, show that if a Poisson cohomology class c belongs to the image of the map $H^k(M) \rightarrow H_\pi^k(M)$, then $i_x^*(c) = 0$ for all $x \in M$.

A more refined but still tractable cohomology, which gives further insight into Poisson cohomology, is provided by localizing at symplectic leaves as follows. Let S be a symplectic leaf of a Poisson manifold (M, π) and consider the space of k -multivector fields along S ,

$$\mathfrak{X}_S^k(M) := \Gamma\left(\bigwedge^k T_S M\right),$$

as well as the obvious restriction map

$$\mathfrak{X}^k(M) \rightarrow \mathfrak{X}_S^k(M), \quad \vartheta \mapsto \vartheta|_S.$$

Exercise 9.42. Let (M, π) be a Poisson manifold, and let $S \subset M$ be a leaf. Show that there exists a unique differential $d_{\pi,S} : \mathfrak{X}_S^k(M) \rightarrow \mathfrak{X}_S^{k+1}(M)$ such that the restriction is a cochain map $(\mathfrak{X}^k(M), d_\pi) \rightarrow (\mathfrak{X}_S^k(M), d_{\pi,S})$.

We will call the cohomology of the complex $(\mathfrak{X}_S^k(M), d_{\pi,S})$ the **Poisson cohomology restricted** to the symplectic leaf S , and we will denote it by $H_{\pi,S}^\bullet(M)$. While the restriction map passes to cohomology yielding a map

$$(9.10) \quad H_\pi^\bullet(M) \rightarrow H_{\pi,S}^\bullet(M),$$

we would like to emphasize that, unlike Poisson cohomology, $H_{\pi,S}^\bullet(M)$ is much more tractable. For instance, one can show that the defining complex is an elliptic complex and, therefore, whenever S is compact, $H_{\pi,S}^\bullet(M)$ is finite dimensional.

Remark 9.43. The solution to Exercise 9.42 should reveal that $A := T_S^*M$ is itself a Lie algebroid over S , for which the inclusion $T_S^*M \hookrightarrow T^*M$ is a Lie algebroid morphism. The resulting cohomology is precisely $H_{\pi,S}^\bullet(M)$ and the restriction map (9.10) is another instance of functoriality with respect to algebroid maps over different bases. What is special about T_S^*M is that it is a *transitive* Lie algebroid, in the sense that it has a *surjective* anchor

$$(9.11) \quad \pi^\#|_S : T_S^*M \rightarrow TS.$$

Precisely this property ensures that the associated complex is elliptic.

The surjectivity of (9.11) gives, via pullback, an inclusion of complexes

$$(\Omega^\bullet(S), d) \hookrightarrow (\mathfrak{X}_S^\bullet(M), d_{\pi,S}).$$

The cohomology of the quotient complex

$$(\mathfrak{X}_S^\bullet(M)/\Omega^\bullet(S), d_{\pi,S})$$

will be called the **Poisson cohomology relative to S** , denoted $H_\pi^\bullet(M, S)$.

The short exact sequence of complexes

$$0 \rightarrow (\Omega^\bullet(S), d) \rightarrow (\mathfrak{X}_S^\bullet(M), d_{\pi,S}) \rightarrow (\mathfrak{X}_S^\bullet(M)/\Omega^\bullet(S), d_{\pi,S}) \rightarrow 0$$

gives rise to a long exact sequence relating the de Rham cohomology of S and the Poisson cohomologies restricted and relative to S :

$$\dots \rightarrow H^k(S) \rightarrow H_{\pi,S}^k(M) \rightarrow H_\pi^k(M, S) \rightarrow H^{k+1}(S) \rightarrow \dots$$

The map obtained by compositing $H_\pi^\bullet(M) \rightarrow H_{\pi,S}^\bullet(M) \rightarrow H_\pi^\bullet(M, S)$ allows us to express obstructions for a Poisson cohomology class to arise from a de Rham cohomology class, a fact that we leave as an exercise.

Exercise 9.44. Show that the image of the map $H^\bullet(M) \rightarrow H_\pi^\bullet(M)$ is contained in the kernel of the map $H_\pi^\bullet(M) \rightarrow H_\pi^\bullet(M, S)$.

The Poisson cohomologies relative to a leaf codify information about the behavior of a Poisson structure in a neighborhood of the leaf. For example, one has the following result from [43]:

Theorem 9.45 (Crainic and Fernandes). *Let S be a compact symplectic leaf of (M, π) with $H_\pi^2(M, S) = 0$. Then there is a Poisson submanifold $S \subset N \subset M$, with $\dim N = \dim H_\pi^1(M, S) + \dim S$, which is a union of symplectic leaves diffeomorphic to S .*

This result is a special instance of a more general theorem concerning families of symplectic leaves of Poisson structures “close enough” to π . This study is beyond the scope of this book, so we refer to [43] for a proof of Theorem 9.45 and its generalizations.

9.5. The cohomological obstruction to linearization

There are important constructions in Poisson geometry that are most naturally expressed in the language of Poisson cohomology. In practice, since the whole Poisson cohomology can be computed only in a few cases, one often has to use other techniques to show, e.g., that a certain obstruction class in Poisson cohomology vanishes. In this section we illustrate this by revisiting the linearization problem, which was discussed at length in Section 3.5.

A key technical tool in linearization problems is the canonical **Euler vector field** E of a vector space V , which is defined as

$$E_v := \left. \frac{d}{dt} \right|_{t=0} e^t v \in T_v V \quad (v \in V),$$

or, in linear coordinates (x^i) on V ,

$$E = \sum_{i=1}^n x^i \frac{\partial}{\partial x^i}.$$

Then the linearity of a Poisson structure π on V can be characterized by the condition that π is exact with primitive the Euler vector field:

$$\pi = d_\pi E (= -\mathcal{L}_E \pi).$$

Clearly, for a linear Poisson structure this holds. The converse, we leave as an exercise:

Exercise 9.46. Let π be a Poisson structure on \mathbb{R}^n .

(a) Show that the equation $\pi = d_\pi E$ amounts to

$$\pi^{ij} = \sum_{k=1}^n x^k \frac{\partial \pi^{ij}}{\partial x^k} \quad (i, j = 1, \dots, n).$$

- (b) Show that the linear functions are the only smooth functions on \mathbb{R}^n satisfying $f = \sum_{k=1}^n x^k \frac{\partial f}{\partial x^k}$.
(HINT: Calculate $\frac{d}{dt}(f(tx)/t)$.)

In order to apply the previous observation to the linearization problem, one needs to be able to recognize the Euler vector field without having a priori the linear coordinates. We say that a vector field $X \in \mathfrak{X}(M)$ on a manifold M is **Euler-like** at $x_0 \in M$ if in local coordinates (U, x^1, \dots, x^n) centered at x_0 one has

$$X|_U = \sum_{i=1}^n x^i \frac{\partial}{\partial x^i} + O(2),$$

where $O(2)$ is a vector field whose components vanish at x_0 up to second order. This condition is independent of the choice of local coordinates.

The following theorem characterizes linearizable Poisson structures:

Theorem 9.47. *Let (M, π) be a Poisson manifold with $\pi_{x_0} = 0$. Then π is linearizable around x_0 if and only if there exists an open set $x_0 \in U \subset M$ and a vector field $X \in \mathfrak{X}(U)$ such that the following hold:*

- (i) X is a primitive of π in U : $\pi|_U = d_\pi X$.
- (ii) X is Euler-like around x_0 .

We already know that (i) and (ii) are necessary conditions for linearization. To prove that they are sufficient, we will use the following version of the Moser deformation argument for Poisson structures:

Theorem 9.48 (Moser's Lemma for Poisson structures). *Let $\{\pi_t\}_{t \in [0,1]}$ be a smooth deformation of Poisson structures on M . Assume that there exists a time-dependent vector field $Y_t \in \mathfrak{X}(M)$, $t \in [0, 1]$, giving primitives for the variations:*

$$\frac{d}{dt} \pi_t = d_{\pi_t} Y_t \quad (t \in [0, 1]).$$

Then the flow ϕ_Y^t of Y_t , whenever defined, satisfies

$$(\phi_Y^t)^* \pi_t = \pi.$$

The proof of Moser's Lemma consists of the usual argument: since

$$\frac{d}{dt} (\phi_Y^t)^* \pi_t = (\phi_Y^t)^* \left(\frac{d}{dt} \pi_t + \mathcal{L}_{Y_t} \pi_t \right) = (\phi_Y^t)^* \left(\frac{d}{dt} \pi_t - d_{\pi_t} Y_t \right) = 0,$$

we must have

$$(\phi_Y^t)^* \pi_t = (\phi_Y^0)^* \pi_0 = \pi.$$

Proof of Theorem 9.47. Using local coordinates, we may assume that $M = \mathbb{R}^n$ and $x_0 = 0$. Let π^{lin} denote the linearization of π at 0, as discussed in Example 3.14. Denote by $m_t : \mathbb{R}^n \rightarrow \mathbb{R}^n$ the multiplication by $t \in \mathbb{R}$; i.e., $m_t(x) = tx$. Consider the following family of Poisson structures joining π to π^{lin} :

$$\pi_t = \begin{cases} tm_t^*(\pi), & \text{if } t \neq 0, \\ \pi^{\text{lin}}, & \text{if } t = 0. \end{cases}$$

Smoothness at $t = 0$ follows by remarking that the coefficients of π_t are the smooth functions $\pi_t^{ij}(x) = \frac{1}{t}\pi^{ij}(tx)$. The variation of the family is

$$\frac{d}{dt}\pi_t = \frac{d}{dt}(tm_t^*(\pi)) = m_t^*(\pi + \mathcal{L}_E\pi) = m_t^*([\pi, X - E]) = d_{\pi_t}Y_t,$$

where we used the relation $\frac{d}{dt}m_t^*(w) = \frac{1}{t}m_t^*(\mathcal{L}_Ew)$ and we set

$$(9.12) \quad Y_t = \frac{1}{t}m_t^*(X - E).$$

By assumption $Y = X - E$ vanishes at 0 up to second order, and because the coefficients of Y_t are given in terms of Y by $Y_t^i(x) = \frac{1}{t^2}Y^i(tx)$, it follows that Y_t is a smooth time-dependent vector field for $t \in [0, 1]$, which satisfies $Y_t(0) = 0$. Hence, there is a some small neighborhood $0 \in V \subset U$ on which the flow $\phi_Y^t : V \rightarrow U$ is defined for all $t \in [0, 1]$. By Moser's Lemma, we obtain a Poisson embedding

$$\phi_Y^1 : (V, \pi^{\text{lin}}) \rightarrow (U, \pi), \quad \text{with } \phi_Y^1(0) = 0.$$

Hence, π is linearizable around $x_0 = 0$. □

Remark 9.49. A more direct argument to prove Theorem 9.47 follows by observing that any Euler-like vector field is in fact the Euler vector field for some coordinate system — see Exercise 9.46. This can be achieved by the same type of Moser argument. Namely, consider the smooth path of vector fields

$$X_t = \begin{cases} m_t^*(X), & \text{if } t \neq 0, \\ E, & \text{if } t = 0. \end{cases}$$

The variation of this path is given by

$$\frac{d}{dt}X_t = \frac{1}{t}m_t^*(\mathcal{L}_EX) = \frac{1}{t}m_t^*([E - X, X]) = -[Y_t, X_t],$$

where $Y_t = \frac{1}{t}m_t^*(X - E)$. The Moser-type calculation yields $\frac{d}{dt}(\phi_Y^t)^*(X_t) = 0$, and so $(\phi_Y^1)^*(X) = E$. Note that Y_t is the same time-dependent vector field (9.12) from the proof of Theorem 9.47.

We obtain the following:

Corollary 9.50. *A vector field $X \in \mathfrak{X}(M)$ is Euler-like at x_0 if and only if there are coordinates centered at x_0 in which X is the Euler vector field.*

Next, we extract from Theorem 9.47 a concrete cohomological obstruction to linearization. Let (M, π) be a Poisson manifold, and let $x_0 \in M$, with $\pi_{x_0} = 0$. Note that the multivector fields that vanish up to order $k \geq 0$ at x_0 form a subcomplex of the Poisson complex, which will be denoted

$$(\mathcal{I}^k(x_0) \cdot \mathfrak{X}^\bullet(M), d_\pi).$$

Let $X \in \mathfrak{X}(M)$ be a vector field that is Euler-like at x_0 (e.g., extend the Euler vector field of a chart).

Exercise 9.51. Show that any Euler-like vector field X at x_0 satisfies

$$\pi - d_\pi X \in \mathcal{I}^2(x_0) \cdot \mathfrak{X}^2(M).$$

The **linearization class** of π at x_0 is the cohomology class

$$\Lambda(\pi, x_0) := [\pi - d_\pi X] \in H^2((\mathcal{I}^2(x_0) \cdot \mathfrak{X}^\bullet(M), d_\pi)).$$

The exercise above shows that this class is indeed well-defined. Moreover, note that if X' is a second Euler-like vector field at x_0 , then

$$(\pi - d_\pi X) - (\pi - d_\pi X') = d_\pi Y, \quad \text{with } Y := X' - X \in \mathcal{I}^2(x_0) \cdot \mathfrak{X}^1(M).$$

Hence the linearization class is independent of the choice of X .

Theorem 9.47 has the following reformulation:

Corollary 9.52. *Let (M, π) be a Poisson manifold with $\pi_{x_0} = 0$. Then π is linearizable around x_0 if and only if the linearization class of π at x_0 is trivial on some open neighborhood $x_0 \in U \subset M$:*

$$\Lambda(\pi|_U, x_0) = 0 \in H^2((\mathcal{I}^2(x_0) \cdot \mathfrak{X}^\bullet(U), d_\pi)).$$

With extra assumptions on the isotropy algebra, the result also implies the following:

Corollary 9.53. *Let (M, π) be a Poisson manifold with $\pi_{x_0} = 0$, and assume that the isotropy Lie algebra \mathfrak{g} at x_0 satisfies the conditions*

$$H^1(\mathfrak{g}) = 0 \quad \text{and} \quad H^1(\mathfrak{g}, \mathfrak{g}) = 0.$$

Then π is linearizable around x_0 if and only if π is exact on some open neighborhood $x_0 \in U \subset M$; i.e.,

$$[\pi|_U] = 0 \in H_\pi^2(U).$$

Proof. If π is linearizable, we have seen that π is exact around x_0 , with primitive the Euler vector field of the coordinates that linearize π .

Conversely, assume that $\pi|_U = d_\pi Y$, for some $Y \in \mathfrak{X}^2(U)$. Let X be an Euler-like vector field at x_0 . By Exercise 9.51, we have that

$$(9.13) \quad d_\pi(Y - X) = \pi - d_\pi X \in \mathcal{I}^2(x_0) \cdot \mathfrak{X}^2(U).$$

Using the identification from Problem 9.15(b), define

$$a_0 := Y - X \bmod \mathcal{I}^1(x_0) \cdot \mathfrak{X}^1(U) \in \mathfrak{g}^*.$$

Using Problem 9.15(b), (9.13) implies that

$$d_{\mathfrak{g}}a_0 = d_{\pi}(Y - X) \bmod \mathcal{I}^1(x_0) \cdot \mathfrak{X}^2(U) = 0.$$

Thus $[a_0] \in H^1(\mathfrak{g}) = 0$, which implies that $a_0 = 0$, and so $Y - X \in \mathcal{I}^1(x_0) \cdot \mathfrak{X}^1(U)$. Then, using again the identification from Problem 9.15(b), define

$$a_1 := Y - X \bmod \mathcal{I}^2(x_0) \cdot \mathfrak{X}^1(U) \in \mathfrak{g}^* \otimes \mathfrak{g},$$

and as above, (9.13) implies that

$$d_{\mathfrak{g}}a_1 = d_{\pi}(Y - X) \bmod \mathcal{I}^2(x_0) \cdot \mathfrak{X}^2(U) = 0.$$

Thus $[a_1] \in H^1(\mathfrak{g}, \mathfrak{g}) = 0$, which implies that $a_1 = d_{\mathfrak{g}}b_1$, for some $b_1 \in \mathfrak{g}$. Let $f \in \mathcal{I}^1(x_0)$ be a smooth function such that

$$f \bmod \mathcal{I}^2(x_0) = b_1 \in \mathfrak{g}.$$

Then

$$Y - X + X_f \bmod \mathcal{I}^2(x_0) \cdot \mathfrak{X}^1(U) = a_1 - d_{\mathfrak{g}}b_1 = 0,$$

and therefore $Z := Y + X_f$ is an Euler-like vector field, which satisfies

$$d_{\pi}(Z) = \pi|_U.$$

Theorem 9.47 implies that π is linearizable around x_0 . □

Let us mention that the assumptions on \mathfrak{g} in the previous corollary hold for any semisimple Lie algebra — see Whitehead's Lemma in Section A.1. However, in order to apply Theorem 9.47, or any of its corollaries, one still needs to solve the cohomological equation. This can be very hard and, in practice, it is usually done through other means — see, e.g., [44] where Conn's Linearization Theorem, Theorem 3.17, is proved by applying this method.

Problems

9.1. Calculate directly the Poisson cohomology of the product $(\mathbb{S}^2, \omega_{\mathbb{S}^2}) \times (\mathbb{R}, 0)$, where $\omega_{\mathbb{S}^2}$ is the standard area form. Compare your result with the decomposition (9.6) from Example 9.35.

9.2. Calculate the Poisson cohomology of $(\mathbb{R}^2, \pi = x \frac{\partial}{\partial x} \wedge \frac{\partial}{\partial y})$ directly, using the definition. Compare your result with what Example 9.37 predicts.

9.3. Find the Poisson cohomology of $(\mathfrak{su}(2)^*, \pi_{\mathfrak{su}(2)})$ using Theorem 9.34.

9.4. Show that Poisson cohomology satisfies the Mayer-Vietoris property: given a Poisson manifold (M, π) , for any open sets $U, V \subset M$ there is a long exact sequence

$$\cdots \rightarrow H_{\pi}^k(U \cup V) \rightarrow H_{\pi}^k(U) \oplus H_{\pi}^k(V) \rightarrow H_{\pi}^k(U \cap V) \rightarrow H_{\pi}^{k+1}(U \cup V) \rightarrow \cdots .$$

9.5. Let (M, π) be a Poisson manifold, and let μ be a volume form on M with corresponding modular vector field X_{μ} . Prove that

$$\left(M \times \mathbb{S}^1, \pi + X_{\mu} \wedge \frac{\partial}{\partial \theta} \right)$$

is a unimodular Poisson manifold.

9.6. For which skew-symmetric matrices A is the associated LV-type Poisson structure π_A on \mathbb{R}^n unimodular?

9.7. Show that for the linear Poisson structure \mathfrak{g}^* the modular class vanishes if and only if \mathfrak{g}^* carries a volume form invariant under the coadjoint action.

9.8. Show that if a Poisson manifold (M, π) is unimodular, then all its isotropy Lie algebras are unimodular — see Exercise 9.19. Explain this result using the map (9.9).

9.9. Let (M, π) be a unimodular Poisson manifold which is nondegenerate on a dense set. Show that π is symplectic.

9.10. Let \mathcal{F} be a foliation on M of codimension q and denote the conormal bundle $\nu^*(\mathcal{F}) := (T\mathcal{F})^{\circ} \subset T^*M$. Assume that \mathcal{F} is coorientable, i.e., the line bundle $\bigwedge^q \nu^*(\mathcal{F})$ is trivializable, and fix a nowhere vanishing section

$$\mu \in \Gamma\left(\bigwedge^q \nu^*(\mathcal{F})\right) \subset \Omega^q(M).$$

(a) For $V \in \Gamma(T\mathcal{F})$, show that

$$\mathcal{L}_V \mu = \alpha_{\mu}(V)\mu,$$

for a unique smooth function $\alpha_\mu(V)$, and that this assignment defines a closed foliated 1-form

$$\alpha_\mu \in \Omega^1(\mathcal{F}), \quad \text{with } d_{\mathcal{F}}\alpha_\mu = 0.$$

(b) Show that the foliated cohomology class

$$\text{mod}(\mathcal{F}) := [\alpha_\mu] \in H^1(\mathcal{F})$$

is independent of the choice of μ . This is the **modular class** of \mathcal{F} .

(c) Show that $\text{mod}(\mathcal{F}) = 0$ if and only if $\bigwedge^q \nu^*(\mathcal{F})$ has a nowhere vanishing section μ which is closed as an element in $\Omega^q(M)$.

9.11. Let (M, π) be a regular Poisson manifold.

(a) Show that there exists a ring homomorphism $H^\bullet(\mathcal{F}_\pi) \rightarrow H^\bullet_\pi(M)$ which makes the following diagram commute:

$$\begin{array}{ccc} H^\bullet(M) & \xrightarrow{\rho^*} & H^\bullet_\pi(M) \\ \downarrow & \nearrow & \\ H^\bullet(\mathcal{F}_\pi) & & \end{array}$$

(b) Show that, when M is orientable, the modular class of the Poisson structure $\text{mod}(M, \pi)$ is precisely the image of the modular class of the foliation $\text{mod}(\mathcal{F}_\pi)$ under the map $H^1(\mathcal{F}_\pi) \rightarrow H^1_\pi(M)$. Moreover, show that

$$\text{mod}(\mathcal{F}_\pi) = 0 \iff \text{mod}(M, \pi) = 0.$$

(c) Consider a Poisson structure in \mathbb{S}^3 with underlying foliation the Reeb foliation — see Example 4.15. Show that its modular class is nontrivial and, in particular, that it is not in the image of $H^1(M) \rightarrow H^1_\pi(M)$.

9.12. Let (M, π) be a Poisson manifold. The **compactly supported Poisson cohomology**, denoted $H^{\bullet,c}_\pi(M)$, is the cohomology of the complex $(\mathfrak{X}^\bullet_c(M), d_\pi)$ of compactly supported multivector fields. Assume that (M, π) is unimodular with invariant volume form μ and define a pairing

$$(\cdot, \cdot) : \mathfrak{X}^k_c(M) \times \mathfrak{X}^{n-k}(M) \rightarrow \mathbb{R}, \quad (\vartheta, \tau) := \int_M \langle \vartheta \wedge \tau, \mu \rangle,$$

where $n = \dim M$. Show that

$$(d_\pi \vartheta, \tau) + (-1)^{\deg \vartheta} (\vartheta, d_\pi \tau) = 0,$$

so one obtains a pairing in cohomology: $(\cdot, \cdot) : H^k_{\pi,c}(M) \times H^{n-k}_\pi(M) \rightarrow \mathbb{R}$.

9.13. Let (M, π) be a Poisson manifold and consider the operator

$$\partial_\pi : \Omega^k(M) \rightarrow \Omega^{k-1}(M), \quad \partial_\pi := i_\pi \circ d - d \circ i_\pi.$$

(a) Show that $\partial_\pi^2 = 0$. The homology of the complex $(\Omega^\bullet(M), \partial_\pi)$ is called the **Poisson homology** of (M, π) and is denoted by $H^\bullet_\pi(M)$.

- (b) Show that the Poisson homology space in degree 0 is the abelianization of the Poisson algebra

$$H_0^\pi(M) := \frac{C^\infty(M)}{\{C^\infty(M), C^\infty(M)\}}.$$

- (c) Let $\Phi : (M, \pi_M) \rightarrow (N, \pi_N)$ be a Poisson map. Show that the pullback map $\Phi^* : (\Omega^\bullet(N), \partial_{\pi_N}) \rightarrow (\Omega^\bullet(M), \partial_{\pi_M})$ is a map of complexes

$$\Phi^* \partial_{\pi_N} = \partial_{\pi_M} \Phi^*,$$

and so it induces a map in Poisson homology: $\Phi^* : H_\bullet^\pi(N) \rightarrow H_\bullet^\pi(M)$.

- (d) Denote by $\langle \cdot, \cdot \rangle : \Omega^k(M) \times \mathfrak{X}^k(M) \rightarrow C^\infty(M)$ the usual pairing between differential forms and multivector fields. Show that

$$\langle \omega, d_\pi \vartheta \rangle - \langle \partial_\pi \omega, \vartheta \rangle = (-1)^k \partial_\pi i_\vartheta \omega$$

and hence that it yields a pairing

$$\langle \cdot, \cdot \rangle : H_k^\pi(M) \times H_\pi^k(M) \rightarrow H_0^\pi(M).$$

9.14. Let μ be a volume form on a manifold M with $\dim M = n$, so we obtain an isomorphism:

$$\mu^\flat : \bigwedge^k TM \rightarrow \bigwedge^{n-k} T^*M, \quad v_1 \wedge \cdots \wedge v_k \mapsto \mu(v_1, \dots, v_k, -, \dots, -).$$

The **curl operator** relative to μ is the unique linear differential operator $D_\mu : \mathfrak{X}^k(M) \rightarrow \mathfrak{X}^{k-1}(M)$ making the following diagram commutative:

$$\begin{array}{ccc} \mathfrak{X}^k(M) & \xrightarrow{\mu^\flat} & \Omega^{n-k}(M) \\ D_\mu \downarrow & & \downarrow d \\ \mathfrak{X}^{k-1}(M) & \xrightarrow{\mu^\flat} & \Omega^{n-k+1}(M) \end{array}$$

- (a) Show that if $\mu' = \pm e^g \mu$ is another volume form, then

$$D_{\mu'} \vartheta = D_\mu \vartheta + [\vartheta, g].$$

- (b) Show that if $\pi \in \mathfrak{X}^2(M)$ is a Poisson structure, then the modular vector field of π with respect to μ is given by $X_\mu = D_\mu \pi$.
- (c) Prove the Schouten bracket can be written as the failure of D_μ satisfying the Leibniz identity; i.e., for all $\zeta \in \mathfrak{X}^j(M)$ and $\vartheta \in \mathfrak{X}^k(M)$,

$$[\zeta, \vartheta] = (-1)^k D_\mu(\zeta \wedge \vartheta) - D_\mu(\zeta) \wedge \vartheta - (-1)^k \zeta \wedge D_\mu(\vartheta).$$

(d) Prove that the following diagram commutes:

$$\begin{array}{ccc}
 \mathfrak{X}^k(M) & \xrightarrow{\mu^b} & \Omega^{n-k}(M) \\
 \downarrow d_\pi + X_\mu \wedge \cdot & & \downarrow (-1)^k \partial_\pi \\
 \mathfrak{X}^{k+1}(M) & \xrightarrow{\mu^b} & \Omega^{n-k-1}(M)
 \end{array}$$

(e) Conclude that the Poisson cohomology and the Poisson homology of a unimodular Poisson manifold (M, π) are isomorphic:

$$H_\pi^k(M) \simeq H_{n-k}^\pi(M).$$

9.15. Let (M, π) be a Poisson manifold, let $x_0 \in M$ be a zero of π , and denote by \mathfrak{g} the isotropy Lie algebra at x_0 .

(a) For $k \geq 0$, show that the multivector fields that vanish at x_0 up to order k form a subcomplex of the Poisson complex

$$(\mathcal{I}^k(x_0) \cdot \mathfrak{X}^\bullet(M), d_\pi).$$

(b) Show that

$$\frac{(\mathcal{I}^k(x_0) \cdot \mathfrak{X}^\bullet(M), d_\pi)}{(\mathcal{I}^{k+1}(x_0) \cdot \mathfrak{X}^\bullet(M), d_\pi)} \simeq \left(\bigwedge^k \mathfrak{g}^* \otimes S^k(\mathfrak{g}), d_{\mathfrak{g}} \right),$$

where the right-hand side is Lie algebra cohomology with coefficients in the k th symmetric power of the adjoint representation.

9.16. Let (M, π) be a Poisson manifold, and let $(N, \pi_N) \hookrightarrow (M, \pi)$ be a corregular Poisson-Dirac submanifold. Denote

$$A_N := (TN^{\perp\pi})^\circ = \{\alpha \in T_N^*M : \pi^\sharp(\alpha) \in TN\}.$$

(a) Show that A_N is a smooth subbundle of T_N^*M and a Lie subalgebroid; i.e., it has an induced Lie algebroid structure for which the inclusion is a Lie algebroid morphism

$$i : (A_N, [\cdot, \cdot]_{A_N}, \rho) \rightarrow (T^*M, [\cdot, \cdot]_\pi, \pi^\sharp).$$

Moreover, show that this map is a fiberwise isomorphism precisely when N is a Poisson submanifold.

(b) Show that the restriction map is a surjective Lie algebroid homomorphism

$$p : (A_N, [\cdot, \cdot]_{A_N}, \rho) \rightarrow (T^*N, [\cdot, \cdot]_{\pi_N}, \pi_N^\sharp),$$

which is an isomorphism precisely when N is a Poisson transversal.

9.17. Let $\theta \in \Omega^1(M, \mathfrak{g})$. Show that θ is a Maurer-Cartan form — see Definition 6.21 — if and only if $\theta : TM \rightarrow \mathfrak{g}$ is a Lie algebroid morphism.

9.18. Let $(A, [\cdot, \cdot]_A, \rho)$ be a Lie algebroid, and let $\alpha \in \Gamma(A)$ be a section. Assuming that the vector field $\rho(\alpha) \in \mathfrak{X}(M)$ is complete, prove that there exists a unique 1-parameter family $\phi_\alpha^t : A \rightarrow A$ of Lie algebroid automorphisms such that for every section $\beta \in \Gamma(A)$,

$$\left. \frac{d}{dt} \right|_{t=0} (\phi_\alpha^t)^*(\beta) = [\alpha, \beta]_A, \quad \phi_\alpha^0 = \text{Id}.$$

One calls ϕ_α^t the **flow of the section** α .

Poisson Homotopy

10.1. Cotangent paths

What is the appropriate notion of path in Poisson geometry? The answer to this question is another illustration of the credo that the right “tangent space” of a Poisson manifold is its cotangent Lie algebroid.

Definition 10.1. A **cotangent path** on a Poisson manifold (M, π) is a smooth path $a : I \rightarrow T^*M$, defined on some interval $I \subset \mathbb{R}$, satisfying

$$\pi^\sharp(a(t)) = \frac{d}{dt} \text{pr} \circ a(t), \quad \forall t \in I,$$

where $\text{pr} : T^*M \rightarrow M$ denotes the projection.

Given a cotangent path $a : I \rightarrow T^*M$ we will denote its **base path** by

$$\gamma_a := \text{pr} \circ a : I \rightarrow M.$$

Here is a first indication that the cotangent paths are the right notion of paths in Poisson geometry:

Proposition 10.2. *Let (M, π) be a Poisson manifold. Two points $x, y \in M$ belong to the same symplectic leaf if and only if there exists a cotangent path $a : [0, 1] \rightarrow T^*M$ with initial point $x = \gamma_a(0)$ and end point $y = \gamma_a(1)$.*

To prove one direction, note that the integral curves of a Hamiltonian vector field X_H can be characterized as the curves $\gamma : I \rightarrow M$ for which $a(t) := dH|_{\gamma(t)}$ is a cotangent path. The converse follows because, if we

consider time-dependent Hamiltonian vector fields, all cotangent paths arise in this way. This is part of the following lemma, which will also be useful later on.

Lemma 10.3. *Let $a : [0, 1] \rightarrow T^*M$ be cotangent path. There exists a smooth family of functions $H_t \in C^\infty(M)$, $t \in [0, 1]$, such that*

$$a(t) = d_{\gamma_a(t)}H_t, \quad \forall t \in [0, 1]$$

where $\gamma_a(t) = \phi_{X_H}^t(\gamma_a(0))$ is an integral curve of X_{H_t} .

Proof. If $\gamma_a([0, 1])$ is contained in the domain of a chart (U, x^i) , in which $a(t) = \sum_{i=1}^n a_i(t)dx^i|_{\gamma_a(t)}$, then one can choose

$$H_t(x) := \sum_{i=1}^n a_i(t)x^i$$

and extend it to a smooth family of functions all supported in some compact set $\gamma_a([0, 1]) \subset K \subset U$.

Choose an open cover $\{I_1, \dots, I_q\}$ of $[0, 1]$ by intervals, such that \bar{I}_p is covered by a chart as above, and choose functions $\{H_t^p\}_{t \in \bar{I}_p}$ as above. Then one can set $H_t := \sum_{p=1}^q \rho_p(t)H_t^p$, where $\{\rho_1, \dots, \rho_q\}$ is a partition of unity on $[0, 1]$ subordinate to the open cover $\{I_1, \dots, I_q\}$.

Thus we constructed H_t with $a(t) = dH_t|_{\gamma_a(t)}$. By using that a is a cotangent path, we obtain that γ_a is an integral curve of X_{H_t} :

$$\frac{d}{dt}\gamma_a(t) = \pi^\sharp(a(t)) = \pi^\sharp(dH_t|_{\gamma_a(t)}) = X_{H_t}|_{\gamma_a(t)}. \quad \square$$

Next, we will study operations with cotangent paths. First, given a cotangent path $a : I \rightarrow T^*M$ and a smooth map $\tau : J \rightarrow I$, the chain rule shows that we have a new cotangent path given by

$$(10.1) \quad a^\tau : J \rightarrow T^*M, \quad t \mapsto \tau'(t) a(\tau(t)).$$

If $\tau : J \rightarrow I$ is a smooth increasing bijection, we call a^τ a **reparameterization** of a .

Lemma 10.4. *Any cotangent path $a : [t_0, t_1] \rightarrow T^*M$ has a reparameterization which vanishes at the end points together with all its derivatives.*

Proof. Take a smooth increasing bijection $\tau : [0, 1] \rightarrow [t_0, t_1]$ with $\tau^{(n)}(0) = \tau^{(n)}(1) = 0$, for all $n \geq 1$. □

Clearly, up to a reparameterization, we may assume that cotangent paths are parameterized by the interval $[0, 1]$.

Next, we discuss concatenation of cotangent paths $a, b : [0, 1] \rightarrow T^*M$ with the property that their base paths can be concatenated; i.e.,

$$\gamma_a(0) = \gamma_b(1).$$

Recall first that for the base paths we have the usual concatenation, which is the new path $\gamma_a \circ \gamma_b$ in M given by

$$\gamma_a \circ \gamma_b(t) := \begin{cases} \gamma_b(2t), & t \in [0, \frac{1}{2}], \\ \gamma_a(2t - 1), & t \in (\frac{1}{2}, 1]. \end{cases}$$

At the cotangent level, one defines the **cotangent concatenation** $a \circ b$ by

$$(10.2) \quad a \circ b(t) := \begin{cases} 2b(2t), & t \in [0, \frac{1}{2}], \\ 2a(2t - 1), & t \in (\frac{1}{2}, 1]. \end{cases}$$

As in the case of the standard concatenation, the concatenation may fail to be smooth. One way around this issue is to allow *piecewise smooth* cotangent paths. Instead we will use reparameterizations to flatten our cotangent paths at the end points. For that, we fix a smooth increasing bijection $\tau : [0, 1] \rightarrow [0, 1]$ with $\tau^{(n)}(0) = \tau^{(n)}(1) = 0$, for all $n \geq 1$ — as in Lemma 10.4 — and we concatenate the τ -reparameterizations. We define the **reparameterized concatenation** \circ_τ by

$$a \circ_\tau b(t) := a^\tau \circ b^\tau(t).$$

Finally, given a cotangent path $a : [0, 1] \rightarrow T^*M$, the **reversed** cotangent path $\bar{a} : [0, 1] \rightarrow T^*M$ is defined by

$$\bar{a}(t) := -a(1 - t).$$

10.2. Cotangent maps

The notion of cotangent path generalizes to maps. If Σ is a manifold, notice that a bundle map

$$\begin{array}{ccc} T\Sigma & \xrightarrow{\Phi} & T^*M \\ \downarrow & & \downarrow \\ \Sigma & \xrightarrow{\phi} & M \end{array}$$

induces a pullback map $\Phi^* : \mathfrak{X}^k(M) \rightarrow \Omega^k(\Sigma)$ given by

$$(\Phi^*\vartheta)_x(v_1, \dots, v_k) = \vartheta_{\phi(x)}(\Phi(v_1), \dots, \Phi(v_k)).$$

Definition 10.5. Let (M, π) be a Poisson manifold. We say that a bundle map $\Phi : T\Sigma \rightarrow T^*M$ is a **cotangent map** if Φ^* intertwines the de Rham and the Poisson differentials:

$$(10.3) \quad d\Phi^* = \Phi^* d_\pi.$$

We denote by the same symbol Φ^* the map induced in cohomology

$$\Phi^* : H_\pi^\bullet(M) \rightarrow H^\bullet(\Sigma).$$

From the Lie algebroid perspective — see Section 9.4 — a cotangent map amounts to a Lie algebroid map $\Phi : T\Sigma \rightarrow T^*M$.

From a more geometric point of view, given a map $\phi : \Sigma \rightarrow M$, one has its “tangent” differential

$$\begin{array}{ccc} T\Sigma & \xrightarrow{d\phi} & TM \\ \downarrow & & \downarrow \\ \Sigma & \xrightarrow{\phi} & M \end{array}$$

(which is a Lie algebroid map!) but there is no intrinsic notion of “contravariant differential” $d^*\phi : T\Sigma \rightarrow T^*M$. This is precisely how one may think of a cotangent map, namely as a pair consisting of

- a smooth map $\phi : \Sigma \rightarrow M$, together with
- the choice of a “contravariant differential” $\Phi : T\Sigma \rightarrow T^*M$ of ϕ ,

satisfying additional conditions. The first one is that the contravariant and the usual differentials must be related by π^\sharp .

Lemma 10.6. *Let (M, π) be a Poisson manifold. For any cotangent map $\Phi : T\Sigma \rightarrow T^*M$ the differential of the base map $\phi : \Sigma \rightarrow M$ satisfies*

$$\begin{array}{ccc} & T^*M & \\ & \nearrow \Phi & \downarrow \pi^\sharp \\ T\Sigma & \xrightarrow{d\phi} & TM \end{array}, \quad d\phi = \pi^\sharp \circ \Phi.$$

Moreover, when Σ is connected, $\phi(\Sigma)$ is contained in a single symplectic leaf.

Proof. The first part is equivalent to (10.3) in degree 0. The second part follows from Proposition 10.2. □

When Σ is 1-dimensional (e.g., $\Sigma = [0, 1]$ or $\Sigma = \mathbb{S}^1$) there are no further restrictions. A cotangent map $\Phi : T\Sigma \rightarrow T^*M$ takes the form $\Phi = a dt$ for

some path $a : I \rightarrow T^*M$ covering a base path $\gamma : I \rightarrow M$:

$$\begin{array}{ccc} TI & \xrightarrow{a dt} & T^*M \\ \downarrow & & \downarrow \\ I & \xrightarrow{\gamma} & M \end{array}$$

Exercise 10.7. Show that a path $a : I \rightarrow T^*M$ is a cotangent path if and only if $a dt : TI \rightarrow T^*M$ is a cotangent map.

When Σ has dimension ≥ 2 condition (10.3) places additional restrictions. These will be discussed in Section 10.4, which includes a detailed analysis of the 2-dimensional case $\Sigma = [0, 1] \times [0, 1]$, necessary to understand cotangent homotopies.

Cotangent maps can be precomposed with the usual smooth maps: given $\Phi : T\Sigma \rightarrow T^*M$ and $\psi : \Sigma_0 \rightarrow \Sigma$, then

$$\Phi \circ d\psi : T\Sigma_0 \rightarrow T^*M$$

is again a cotangent map. Indeed, the map induced on the cochain complexes is a composition of cochain maps:

$$(\mathfrak{X}^\bullet(M), d_\pi) \xrightarrow{\Phi^*} (\Omega^\bullet(\Sigma), d) \xrightarrow{\psi^*} (\Omega^\bullet(\Sigma_0), d).$$

The reparametrization of cotangent paths is a particular case of this operation: if $a : I \rightarrow T^*M$ is a cotangent path and $\tau : J \rightarrow I$ is a smooth map, then the reparametrized cotangent map $a^\tau : J \rightarrow T^*M$ satisfies

$$(adt) \circ d\tau = \tau'(t)a(t)dt = a^\tau dt.$$

Another interesting case is when ψ is the inclusion of a submanifold:

Definition 10.8. Given a cotangent map $\Phi : T\Sigma \rightarrow T^*M$, its **restriction to a submanifold** $\Sigma_0 \subset \Sigma$ is the new cotangent map

$$\Phi|_{\Sigma_0} := \Phi|_{T\Sigma_0} : T\Sigma_0 \rightarrow T^*M.$$

We also allow Σ to be a manifold with boundary. In this case, we define the **boundary of a cotangent map** $\Phi : T\Sigma \rightarrow T^*M$ to be the restriction of Φ to $\partial\Sigma$. It is the cotangent map

$$(10.4) \quad \partial\Phi := \Phi|_{\partial\Sigma} : T(\partial\Sigma) \rightarrow T^*M.$$

Next, we move to cotangent homotopies.

Definition 10.9. Let (M, π) be a Poisson manifold, and let Σ be a manifold without boundary. Two cotangent maps $\Phi_0, \Phi_1 : T\Sigma \rightarrow T^*M$ are called **cotangent homotopic** if there exists a cotangent map

$$\Phi : T(\Sigma \times [0, 1]) \rightarrow T^*M$$

such that

$$\Phi|_{\Sigma \times \{0\}} = \Phi_0 \quad \text{and} \quad \Phi|_{\Sigma \times \{1\}} = \Phi_1.$$

As expected, homotopic maps induce the same map in cohomology:

Proposition 10.10. *Let (M, π) be a Poisson manifold. Two cotangent homotopic maps $\Phi_0, \Phi_1 : T\Sigma \rightarrow T^*M$ induce the same map in cohomology:*

$$(\Phi_0)^* = (\Phi_1)^* : H_\pi^\bullet(M) \rightarrow H^\bullet(\Sigma).$$

Proof. Let $\Phi : T(\Sigma \times [0, 1]) \rightarrow T^*M$ be a cotangent homotopy between Φ_0 and Φ_1 . Also, let $i_0 : \Sigma \hookrightarrow \Sigma \times [0, 1]$, $x \mapsto (x, 0)$ and $i_1 : \Sigma \hookrightarrow \Sigma \times [0, 1]$, $x \mapsto (x, 1)$, so that we have a diagram

$$H_\pi^\bullet(M) \xrightarrow{\Phi^*} H^\bullet(\Sigma \times [0, 1]) \begin{matrix} \xrightarrow{i_1^*} \\ \xrightarrow{i_0^*} \end{matrix} H^\bullet(\Sigma)$$

where the top composition yields $(\Phi_1)^* : H_\pi^\bullet(M) \rightarrow H^\bullet(\Sigma)$ and the bottom composition yields $(\Phi_0)^* : H_\pi^\bullet(M) \rightarrow H^\bullet(\Sigma)$. Since the maps induced by i_0 and i_1 on cohomology are identical, the result follows. \square

10.3. Integration and the contravariant Stokes Theorem

Recall that 1-forms can be integrated along paths. Recall also that, by the Fundamental Theorem of Calculus and Stokes’s Theorem, one has the following:

- (i) For an exact 1-form dH , the integral over $\gamma : [0, 1] \rightarrow M$ only depends on the end points of the path:

$$\int_\gamma dH = H(\gamma(1)) - H(\gamma(0)).$$

- (ii) For a closed 1-form α , if γ_0 and γ_1 are either homologous loops or homotopic paths, one has

$$\int_{\gamma_0} \alpha = \int_{\gamma_1} \alpha.$$

In particular, it follows that the integral along a loop $\gamma : \mathbb{S}^1 \rightarrow M$ determines a linear functional in de Rham cohomology:

$$\int_{\gamma} : H^1(M) \rightarrow \mathbb{R}, \quad [\alpha] \mapsto \int_{\gamma} \alpha.$$

For the analogous statements in Poisson geometry, one should replace paths by cotangent paths and closed/exact 1-forms by Poisson/Hamiltonian vector fields.

Definition 10.11. Let (M, π) be a Poisson manifold. The **integral of a vector field $X \in \mathfrak{X}(M)$ along a cotangent path $a : I \rightarrow T^*M$** is the number

$$\int_a X := \int_I \langle a(t), X_{\gamma_a(t)} \rangle dt.$$

The following are immediate consequences of the definitions:

Proposition 10.12. *The integral along cotangent paths satisfies the following:*

- (i) *It is invariant under reparameterizations: $\int_{a\tau} X = \int_a X$.*
- (ii) *It is additive relative to concatenation: $\int_{a_1 \circ a_2} X = \int_{a_1} X + \int_{a_2} X$.*
- (iii) *It changes sign on the reverse path $\int_{\bar{a}} X = -\int_a X$.*
- (iv) *On exact vector fields $d_{\pi}H = -X_H$, it depends only on the end points:*

$$\int_a d_{\pi}H = H(\gamma_a(1)) - H(\gamma_a(0)).$$

In particular, this proposition shows that the integral along a cotangent path a whose base path is closed defines a linear functional

$$\int_a : H^1_{\pi}(M) \rightarrow \mathbb{R}, \quad [X] \mapsto \int_a X.$$

What about the invariance of the integral under homotopy of cotangent paths? It is easy to give examples of Poisson vector fields $X \in \mathfrak{X}(M, \pi)$ and of (naive) homotopies of cotangent paths $a_{\varepsilon} : I \rightarrow T^*M$, $\varepsilon \in [0, 1]$, for which

$$\int_{a_0} X \neq \int_{a_1} X.$$

Example 10.13. Consider the regular Poisson structure on \mathbb{R}^3 given by

$$\pi = \frac{\partial}{\partial x} \wedge \frac{\partial}{\partial y}.$$

Let $\gamma_\varepsilon(t) = (x_\varepsilon(t), y_\varepsilon(t), 0)$, $\varepsilon \in [0, 1]$, be any ordinary homotopy of smooth paths, with fixed end points, lying in the plane $z = 0$. Then we have a smooth family of cotangent paths $a_\varepsilon : [0, 1] \rightarrow T^*\mathbb{R}^3$ over γ_ε , defined by

$$a_\varepsilon(t) = \dot{y}_\varepsilon(t) dx|_{\gamma_\varepsilon(t)} - \dot{x}_\varepsilon(t) dy|_{\gamma_\varepsilon(t)} + \varepsilon dz|_{\gamma_\varepsilon(t)}.$$

If we consider the Poisson vector field $X = \frac{\partial}{\partial z}$, we have

$$\langle a_\varepsilon(t), X_{\gamma_\varepsilon(t)} \rangle = \varepsilon,$$

so we find $\int_{a_\varepsilon} X = \varepsilon$ and it follows that $\int_{a_0} X \neq \int_{a_1} X$. 

For the correct notion of homotopy of cotangent paths with fixed end points we should keep in mind that T^*M is the correct “tangent space”. This notion will be introduced in the next section.

Integration can be defined more generally over cotangent maps:

Definition 10.14. Let $\Phi : T\Sigma \rightarrow T^*M$ be a cotangent map into a Poisson manifold (M, π) , where Σ is a compact, oriented, k -dimensional manifold. The **integral of $\vartheta \in \mathfrak{X}^k(M)$ along the cotangent map Φ** is defined as

$$\int_\Phi \vartheta := \int_\Sigma \Phi^* \vartheta.$$

It should be clear that, in the case of an interval $\Sigma = I$, we recover the integral along a cotangent path.

Since the integral can be expressed as the composition

$$\int_\Phi : \mathfrak{X}^k(M) \xrightarrow{\Phi^*} \Omega^k(\Sigma) \xrightarrow{\int_\Sigma} \mathbb{R}$$

it follows that, if $\partial\Sigma = \emptyset$, it induces a map in cohomology

$$\int_\Phi : H_\pi^k(M) \xrightarrow{\Phi^*} H^k(\Sigma) \xrightarrow{\int_\Sigma} \mathbb{R}.$$

From the homotopy invariance of Proposition 10.10 we deduce:

Corollary 10.15. For any d_π -closed multivector field $\vartheta \in \mathfrak{X}^k(M)$ and any cotangent homotopic maps $\Phi_0, \Phi_1 : T\Sigma \rightarrow T^*M$ defined on a compact, oriented, k -dimensional manifold (without boundary) Σ one has

$$\int_{\Phi_0} \vartheta = \int_{\Phi_1} \vartheta.$$

We also have a contravariant version of Stokes’s Theorem — recall the definition (10.4) for the boundary of a cotangent map:

Theorem 10.16 (Contravariant Stokes’s Theorem). *Let $\Phi : T\Sigma \rightarrow T^*M$ be a cotangent map into a Poisson manifold (M, π) , where Σ is a compact, oriented manifold of dimension k with boundary. For any multivector field $\vartheta \in \mathfrak{X}^{k-1}(M)$ one has*

$$\int_{\Phi} d_{\pi} \vartheta = \int_{\partial \Phi} \vartheta.$$

Proof. Using the definition of the integral, the cotangent map condition, and Stokes’s Theorem for differential forms, we have

$$\int_{\Phi} d_{\pi} \vartheta = \int_{\Sigma} \Phi^* d_{\pi} \vartheta = \int_{\Sigma} d \Phi^* \vartheta = \int_{\partial \Sigma} \Phi^* \vartheta = \int_{\partial \Phi} \vartheta. \quad \square$$

10.4. Cotangent path-homotopy

While Definition 10.5 of a cotangent map Φ is stated in a simple form as the compatibility between the de Rham and the Poisson differential (10.3), it hides quite a lot of information. For example, we already saw in Lemma 10.6 a first restriction: the compatibility of Φ with the differential $d\phi$ of its base map. When Σ is 1-dimensional this is the only condition, but we will see now that for higher dimensions there are more conditions. We will focus mainly on the case when Σ has dimension 2 and in particular when Σ is the square $[0, 1] \times [0, 1]$. This already reveals what to expect in higher dimensions, and it is also the case relevant to understanding cotangent homotopies and the Poisson homotopy groups.

When $\Sigma = [0, 1] \times [0, 1]$, with coordinates (t, ε) , we decompose a bundle map $\Phi : T\Sigma \rightarrow T^*M$ as

$$\Phi = \Phi_1 dt + \Phi_2 d\varepsilon : T([0, 1] \times [0, 1]) \rightarrow T^*M.$$

The map Φ (hence also Φ_1 and Φ_2) covers a base map $\gamma : [0, 1] \times [0, 1] \rightarrow T^*M$. Lemma 10.6 tells us that, for Φ to be a cotangent map, we must first have the following:

- For fixed ε , the map $t \mapsto \Phi_1(t, \varepsilon)$ is a cotangent path covering the path $t \mapsto \gamma(t, \varepsilon)$.
- For fixed t , the map $\varepsilon \mapsto \Phi_2(t, \varepsilon)$ is a cotangent path covering the path $\varepsilon \mapsto \gamma(t, \varepsilon)$.

As explained before, intuitively one may think of these two maps as the “contravariant derivatives” of γ in the directions t and ε , respectively.

Therefore, one should expect an additional condition relating them, reflecting the usual commutation relation for a map $\gamma : [0, 1] \times [0, 1] \rightarrow \mathbb{R}^n$

$$\frac{d}{dt} \frac{d}{d\varepsilon} \gamma(t, \varepsilon) = \frac{d}{d\varepsilon} \frac{d}{dt} \gamma(t, \varepsilon).$$

Note, however, that already in the case where $\gamma : [0, 1] \times [0, 1] \rightarrow M$ takes values in a manifold M , to write this relation coordinate free requires some care. One way to state this property for manifolds is by using 1-forms:

- For any smooth map $\gamma = \gamma(t, \varepsilon) : [0, 1] \times [0, 1] \rightarrow M$ and any 1-form $\theta \in \Omega^1(M)$ the following equality holds:

$$(10.5) \quad \frac{d}{dt} \left(\theta \left(\frac{d\gamma}{d\varepsilon} \right) \right) - \frac{d}{d\varepsilon} \left(\theta \left(\frac{d\gamma}{dt} \right) \right) = d\theta \left(\frac{d\gamma}{dt}, \frac{d\gamma}{d\varepsilon} \right).$$

The next result contains a version of this formula for cotangent maps and shows that this is precisely the kind of extra condition that is encoded in the definition of a cotangent map when Σ has dimension 2:

Proposition 10.17. *Let (M, π) be a Poisson manifold, and consider a bundle map $\Phi = \Phi_1 dt + \Phi_2 d\varepsilon : T([0, 1] \times [0, 1]) \rightarrow T^*M$ with base map $\gamma : [0, 1] \times [0, 1] \rightarrow M$. Assume that Φ is compatible with its base map:*

$$\pi^\# \circ \Phi = d\gamma.$$

Then the following are equivalent:

- (i) Φ is a cotangent map.
- (ii) For any vector field $X \in \mathfrak{X}(M)$, one has

$$\frac{d}{dt} \langle X, \Phi_2 \rangle - \frac{d}{d\varepsilon} \langle X, \Phi_1 \rangle = (d_\pi X)(\Phi_1, \Phi_2).$$

- (iii) For any (t, ε) -dependent 1-forms $\alpha_{t,\varepsilon}, \beta_{t,\varepsilon} \in \Omega^1(M)$ such that

$$\alpha_{t,\varepsilon}|_{\gamma(t,\varepsilon)} = \Phi_1(t, \varepsilon) \quad \text{and} \quad \beta_{t,\varepsilon}|_{\gamma(t,\varepsilon)} = \Phi_2(t, \varepsilon),$$

one has

$$\left(\frac{d}{dt} \beta_{t,\varepsilon} - \frac{d}{d\varepsilon} \alpha_{t,\varepsilon} \right) \Big|_{\gamma(t,\varepsilon)} = -[\alpha_{t,\varepsilon}, \beta_{t,\varepsilon}]_\pi \Big|_{\gamma(t,\varepsilon)}.$$

Proof. (i) \Leftrightarrow (ii). For any $X \in \mathfrak{X}(M)$, by using (10.5) for $\theta = \Phi^* X$ we find that

$$\begin{aligned} (\Phi^* d_\pi X - d\Phi^* X) \left(\frac{d}{dt}, \frac{d}{d\varepsilon} \right) &= (d_\pi X) \left(\Phi \left(\frac{d}{dt} \right), \Phi \left(\frac{d}{d\varepsilon} \right) \right) - (d\Phi^* X) \left(\frac{d}{dt}, \frac{d}{d\varepsilon} \right) \\ &= (d_\pi X)(\Phi_1, \Phi_2) - \frac{d}{dt} \left((\Phi^* X) \left(\frac{d}{d\varepsilon} \right) \right) + \frac{d}{d\varepsilon} \left((\Phi^* X) \left(\frac{d}{dt} \right) \right) \\ &= (d_\pi X)(\Phi_1, \Phi_2) - \frac{d}{dt} \langle X, \Phi_2 \rangle + \frac{d}{d\varepsilon} \langle X, \Phi_1 \rangle. \end{aligned}$$

Compatibility of Φ with its base map γ can be written as

$$\Phi^* d_\pi f = d\Phi^* f, \quad \forall f \in C^\infty(M),$$

and so (ii) holds if and only if $\Phi^* d_\pi = d\Phi^*$ holds in degree 0 and degree 1. However, since $[0, 1] \times [0, 1]$ is 2-dimensional, this holds in all degrees — see Problem 10.4) for a more general fact. This shows (i) \Leftrightarrow (ii).

(ii) \Leftrightarrow (iii). Let $\alpha_{\varepsilon,t}$ and $\beta_{\varepsilon,t}$ be as in the statement of the theorem. The definition of d_π gives

$$\begin{aligned} (d_\pi X)(\Phi_1, \Phi_2) &= (d_\pi X)(\alpha_{t,\varepsilon}, \beta_{t,\varepsilon})|_{\gamma(t,\varepsilon)} \\ &= (\mathcal{L}_{\pi^\#(\alpha_{t,\varepsilon})}\langle X, \beta_{t,\varepsilon} \rangle - \mathcal{L}_{\pi^\#(\beta_{t,\varepsilon})}\langle X, \alpha_{t,\varepsilon} \rangle - \langle X, [\alpha_{t,\varepsilon}, \beta_{t,\varepsilon}]_\pi \rangle)|_{\gamma(t,\varepsilon)} \\ &= \left\langle d\langle X, \beta_{t,\varepsilon} \rangle, \frac{d\gamma}{dt}(t, \varepsilon) \right\rangle - \left\langle d\langle X, \alpha_{t,\varepsilon} \rangle, \frac{d\gamma}{d\varepsilon}(t, \varepsilon) \right\rangle - \langle X, [\alpha_{t,\varepsilon}, \beta_{t,\varepsilon}]_\pi \rangle|_{\gamma(t,\varepsilon)} \end{aligned}$$

where we used that Φ is compatible with $d\gamma$, so that

$$\pi^\#(\alpha_{t,\varepsilon})|_{\gamma(t,\varepsilon)} = \frac{d\gamma}{dt}(t, \varepsilon), \quad \pi^\#(\beta_{t,\varepsilon})|_{\gamma(t,\varepsilon)} = \frac{d\gamma}{d\varepsilon}(t, \varepsilon).$$

On the other hand, we find that

$$\frac{d}{dt}\langle X, \Phi_2 \rangle - \frac{d}{d\varepsilon}\langle X, \Phi_1 \rangle = \frac{d}{dt}(\langle X, \beta_{t,\varepsilon} \rangle(\gamma(t, \varepsilon))) - \frac{d}{d\varepsilon}(\langle X, \alpha_{t,\varepsilon} \rangle(\gamma(t, \varepsilon))).$$

Therefore, using that Φ is compatible with γ , (ii) is equivalent to

$$\begin{aligned} &\frac{d}{dt}(\langle X, \beta_{t,\varepsilon} \rangle(\gamma(t, \varepsilon))) - \frac{d}{d\varepsilon}(\langle X, \alpha_{t,\varepsilon} \rangle(\gamma(t, \varepsilon))) \\ &= \left\langle d\langle X, \beta_{t,\varepsilon} \rangle, \frac{d\gamma}{dt}(t, \varepsilon) \right\rangle - \left\langle d\langle X, \alpha_{t,\varepsilon} \rangle, \frac{d\gamma}{d\varepsilon}(t, \varepsilon) \right\rangle - \langle X, [\alpha_{t,\varepsilon}, \beta_{t,\varepsilon}]_\pi \rangle|_{\gamma(t,\varepsilon)}. \end{aligned}$$

This last relation is equivalent to the identity,

$$\left\langle X, \frac{d}{dt}\beta_{t,\varepsilon} - \frac{d}{d\varepsilon}\alpha_{t,\varepsilon} \right\rangle|_{\gamma(t,\varepsilon)} = -\langle X, [\alpha_{t,\varepsilon}, \beta_{t,\varepsilon}]_\pi \rangle|_{\gamma(t,\varepsilon)},$$

which is clearly equivalent to (iii). □

Next, we introduce the notion of cotangent *path*-homotopy. Recall that a path-homotopy between ordinary paths $\gamma_0, \gamma_1 : [0, 1] \rightarrow M$ is a homotopy

$$\gamma = \gamma(t, \varepsilon) : [0, 1] \times [0, 1] \rightarrow M$$

such that the paths $t \mapsto \gamma(t, \varepsilon)$ all start and end at the same point:

$$\begin{aligned} \gamma(t, 0) &= \gamma_0(t), & \gamma(t, 1) &= \gamma_1(t), & \forall t \in [0, 1], \\ \gamma(0, \varepsilon) &= x_0, & \gamma(1, \varepsilon) &= x_1, & \forall \varepsilon \in [0, 1]. \end{aligned}$$

When adapting this notion to the contravariant setting, one needs to take into account that cotangent maps play the role of a “contravariant derivative” of their base map:

Definition 10.18. Two cotangent paths $a_0, a_1 : [0, 1] \rightarrow T^*M$ in a Poisson manifold are called **cotangent path-homotopic** if there exists a cotangent map $\Phi : T([0, 1] \times [0, 1]) \rightarrow T^*M$ such that

$$(10.6) \quad \partial\Phi(t, 0) = a_0(t), \quad \partial\Phi(t, 1) = a_1(t), \quad \forall t \in [0, 1],$$

$$(10.7) \quad \partial\Phi(0, \varepsilon) = 0, \quad \partial\Phi(1, \varepsilon) = 0, \quad \forall \varepsilon \in [0, 1].$$

We also call Φ a **cotangent path-homotopy**.

Explicitly, a cotangent path-homotopy between a_0 and a_1 is a cotangent map

$$\Phi = \Phi_1 dt + \Phi_2 d\varepsilon : T([0, 1] \times [0, 1]) \rightarrow T^*M$$

with the following properties:

- (i) Its base map $\gamma : [0, 1] \times [0, 1] \rightarrow M$ is a path-homotopy.
- (ii) For all $\varepsilon \in [0, 1]$ one has $\Phi_2(0, \varepsilon) = 0, \Phi_2(1, \varepsilon) = 0$.
- (iii) For all $t \in [0, 1]$ one has $\Phi_1(t, 0) = a_0(t), \Phi_1(t, 1) = a_1(t)$.

Actually, looking back at Definition 10.8 concerning the restriction of cotangent maps $\Phi : T\Sigma \rightarrow T^*M$ to submanifolds, it should be clear how to make sense of Φ being constant along a submanifold $\Sigma_0 \subset \Sigma$:

$$\phi|_{\Sigma_0} = \text{constant}, \quad \Phi|_{T\Sigma_0} = 0.$$

Conditions (i) and (ii) simply mean that Φ is constant on $\{0\} \times [0, 1]$ and $\{1\} \times [0, 1]$.

Lemma 10.19. *Cotangent path-homotopy is an equivalence relation.*

Proof. For reflexivity we can use the constant cotangent path-homotopy in the ε -direction. For symmetry we can use the reversed cotangent path-homotopy in the ε -direction. For transitivity we can concatenate two cotangent path-homotopies in the ε -direction. However, to ensure smoothness, before we concatenate, we reparameterize the path-homotopies as follows. Let $\tau : [0, 1] \rightarrow [0, 1]$ be a smooth map such that

$$\tau(\varepsilon) = 0, \text{ for } 0 \leq \varepsilon \leq \frac{1}{3}, \quad \text{and} \quad \tau(\varepsilon) = 1, \text{ for } \frac{2}{3} \leq \varepsilon \leq 1.$$

Set $\psi := \text{Id} \times \tau : [0, 1] \times [0, 1] \rightarrow [0, 1] \times [0, 1]$. Given a cotangent path-homotopy $\Phi : T([0, 1] \times [0, 1]) \rightarrow T^*M$ between a_0 and a_1 , we replace it by the new cotangent path-homotopy $\Phi \circ d\psi$ between a_0 and a_1 . □

The following exercises and examples illustrate how cotangent path-homotopy can differ from ordinary path-homotopy.

Exercise 10.20 (Symplectic manifolds). Let (M, π) be a nondegenerate Poisson manifold. Show that two cotangent paths $a_0, a_1 : [0, 1] \rightarrow T^*M$ are cotangent path-homotopic if and only if their base paths $\gamma_0, \gamma_1 : [0, 1] \rightarrow M$ are path-homotopic.

Exercise 10.21 (Zero Poisson structures). Let M be a manifold equipped with the zero Poisson structure, so a cotangent path $a : [0, 1] \rightarrow T^*M$ is just a path in a cotangent space $a : [0, 1] \rightarrow T_x^*M$. Show that two cotangent paths $a_0, a_1 : [0, 1] \rightarrow T_x^*M$ are cotangent path-homotopic if and only if

$$\int_0^1 a_0(t) dt = \int_0^1 a_1(t) dt.$$

Example 10.22 (Regular Poisson structures). Assume that $M = S \times \mathbb{R}^q$ is a regular Poisson manifold with symplectic leaves,

$$S_y = S \times \{y\} \quad (y \in \mathbb{R}^q),$$

and denote the symplectic form on S_y by $\omega_y \in \Omega^2(S_y)$. At each $(s, y) \in M$ we have a natural identification

$$(10.8) \quad T_{(s,y)}M = T_sS_y \oplus T_y\mathbb{R}^q = T_sS_y \oplus \mathbb{R}^q.$$

By using the leafwise symplectic form, we also obtain a decomposition

$$(10.9) \quad T_{(s,y)}^*M \simeq T_s^*S_y \oplus (\mathbb{R}^q)^*.$$

In particular, a cotangent path $a : [0, 1] \rightarrow T^*M$ with base path lying in the leaf S_y can be identified with a pair $a(t) = (\dot{\gamma}(t), f(t))$, where $\gamma : [0, 1] \rightarrow S_y$ is an ordinary path in the leaf S_y and $f : [0, 1] \rightarrow (\mathbb{R}^q)^*$.

Given two cotangent paths $a_0(t) = (\dot{\gamma}_0(t), f_0(t))$ and $a_1(t) = (\dot{\gamma}_1(t), f_1(t))$ with the same end points, we claim that they are cotangent homotopic if and only if there is a path-homotopy $\gamma(t, \varepsilon)$ between γ_0 and γ_1 such that

$$(10.10) \quad \int_0^1 f_1(t) dt - \int_0^1 f_0(t) dt = - \int_0^1 \int_0^1 d\omega \left(\frac{\partial \gamma}{\partial t}, \frac{\partial \gamma}{\partial \varepsilon}, - \right) d\varepsilon dt,$$

where $\omega \in \Omega^2(M)$ denotes the unique 2-form with kernel $T\mathbb{R}^q$ extending the leafwise forms ω_y , and we regard

$$d\omega \left(\frac{\partial \gamma}{\partial t}, \frac{\partial \gamma}{\partial \varepsilon}, - \right) \in (\mathbb{R}^q)^*,$$

by using the decomposition (10.8) and the fact that the pullback of $d\omega$ to S_y vanishes. This claim will follow from a series of exercises that should help familiarize the reader with the notion of cotangent homotopy.

Exercise 10.23. Show that under the identification

$$\Omega^1(M) \simeq \mathfrak{X}(\mathcal{F}_\pi) \oplus C^\infty(M; (\mathbb{R}^q)^*),$$

induced by (10.9), the Lie bracket on 1-forms determined by π becomes

$$[(X, F), (Y, G)]_\pi = ([X, Y], \mathcal{L}_X G - \mathcal{L}_Y F + d\omega(X, Y, -))$$

where $d\omega(X, Y, -)$ denotes a function in $C^\infty(M; (\mathbb{R}^q)^*)$ which at $(s, y) \in M$ takes the value $w \mapsto (d\omega)_{(s,y)}(X, Y, w)$.

Exercise 10.24. Assume that one has a bundle map

$$\Phi = \Phi_1(t, \varepsilon) dt + \Phi_2(t, \varepsilon) d\varepsilon : T([0, 1] \times [0, 1]) \rightarrow T^*M$$

which is compatible with its base map $\gamma : [0, 1] \times [0, 1] \rightarrow M$; i.e., $\pi^\sharp \circ \Phi = d\gamma$. Write the components of Φ using (10.9) in the form

$$\begin{aligned} \Phi_1(t, \varepsilon) &= \left(\frac{\partial \gamma}{\partial t}, f(t, \varepsilon) \right), & f : [0, 1] \times [0, 1] &\rightarrow (\mathbb{R}^q)^*, \\ \Phi_2(t, \varepsilon) &= \left(\frac{\partial \gamma}{\partial \varepsilon}, g(t, \varepsilon) \right), & g : [0, 1] \times [0, 1] &\rightarrow (\mathbb{R}^q)^*, \end{aligned}$$

and show that Φ is a cotangent path-homotopy if and only if

$$\begin{cases} \frac{\partial f}{\partial \varepsilon} - \frac{\partial g}{\partial t} = -d\omega\left(\frac{\partial \gamma}{\partial t}, \frac{\partial \gamma}{\partial \varepsilon}, -\right), \\ g(0, \varepsilon) = g(1, \varepsilon) = 0, \quad \forall \varepsilon \in [0, 1]. \end{cases}$$

Integrating the equation in the previous exercise w.r.t. t , we obtain

$$\int_0^1 \frac{\partial f}{\partial \varepsilon} dt = - \int_0^1 d\omega\left(\frac{\partial \gamma}{\partial t}, \frac{\partial \gamma}{\partial \varepsilon}, -\right) dt,$$

and then, integrating this equation w.r.t. ε , we obtain

$$\int_0^1 f(t, 0) dt - \int_0^1 f(t, 1) dt = \int_0^1 \int_0^1 d\omega\left(\frac{\partial \gamma}{\partial t}, \frac{\partial \gamma}{\partial \varepsilon}, -\right) dt d\varepsilon.$$

So (10.10) needs to hold if a_0 and a_1 are cotangent path-homotopic.

Conversely, if (10.10) holds, using Exercise 10.24 one checks that a cotangent path-homotopy $\Phi = \Phi_1(t, \varepsilon) dt + \Phi_2(t, \varepsilon) d\varepsilon : T([0, 1] \times [0, 1]) \rightarrow T^*M$ joining a_0 to a_1 is given by

$$\Phi_1(t, \varepsilon) = \left(\frac{\partial \gamma}{\partial t}, f(t, \varepsilon) \right), \quad \Phi_2(t, \varepsilon) = \left(\frac{\partial \gamma}{\partial \varepsilon}, g(t, \varepsilon) \right),$$

where f and g are defined by

$$\begin{aligned} f(t, \varepsilon) &= (1 - \varepsilon)f_0(t) + \varepsilon f_1(t) + \varepsilon \int_0^1 \theta(t, \delta) d\delta - \int_0^\varepsilon \theta(t, \delta) d\delta, \\ g(t, \varepsilon) &= \int_0^t (f_1(s) - f_0(s)) ds + \int_0^t \int_0^1 \theta(s, \delta) ds d\delta, \end{aligned}$$

and we have set

$$\theta(t, \varepsilon) := d\omega\left(\frac{\partial\gamma}{\partial t}, \frac{\partial\gamma}{\partial\varepsilon}, -\right)(t, \varepsilon). \quad \curvearrowright$$

Finally, we are able to prove that the integral of Poisson vector fields is invariant under cotangent path-homotopy:

Proposition 10.25. *Let (M, π) be a Poisson manifold. For any Poisson vector field $X \in \mathfrak{X}(M, \pi)$ and any two cotangent paths $a_0, a_1 : [0, 1] \rightarrow T^*M$ which are cotangent path-homotopic, one has*

$$\int_{a_0} X = \int_{a_1} X.$$

Proof. One can use the characterization of cotangent path-homotopy from (ii) of Proposition 10.17, where the right-hand side vanishes. Integrating the resulting equation with respect to t and using $\Phi_2(0, \varepsilon) = 0, \Phi_2(1, \varepsilon) = 0$, the desired equality follows.

Alternatively, one can use Stokes’s Theorem. Given a cotangent path-homotopy $\Phi : T([0, 1] \times [0, 1]) \rightarrow T^*M$ between a_0 and a_1 , the boundary $\partial\Phi$ consists of the concatenation of four paths, namely $a_0, 0_{x_1}, \bar{a}_1$, and 0_{x_0} . Hence,

$$\int_{\partial\Phi} X = \int_{a_0} X + \int_{0_{x_1}} X + \int_{\bar{a}_1} X + \int_{0_{x_0}} X = \int_{a_0} X - \int_{a_1} X.$$

On the other hand, by Stokes’s Theorem,

$$\int_{\partial\Phi} X = \int_{\Phi} d_{\pi}X = 0. \quad \square$$

10.5. Poisson homotopy and homology groups

Using concatenation (10.2) of cotangent paths, we now define the Poisson homotopy groups in complete analogy with the usual fundamental groups of manifolds:

Definition 10.26. The **Poisson homotopy group** of a Poisson manifold (M, π) with base point $x \in M$ is

$$\Pi(M, \pi, x) := \frac{\text{cotangent paths covering a closed path at } x}{\text{cotangent path-homotopy}}$$

with the group operation \cdot induced by

$$(10.11) \quad [a] \cdot [b] = [a \circ b],$$

for any cotangent paths $a, b : [0, 1] \rightarrow T^*M$ with the property that $a \circ b$ is smooth.

Lemma 10.27. *The operation (10.11) is well-defined and it gives $\Pi(M, \pi, x)$ the structure of a group.*

Proof. To prove that the operation is well-defined we show the following:

- (i) For any smooth map $\tau : [0, 1] \rightarrow [0, 1]$ with $\tau(0) = 0$ and $\tau(1) = 1$, the reparameterization a^τ (see (10.1)) is cotangent path-homotopic to a .
- (ii) There exist cotangent paths $a_1, b_1 : [0, 1] \rightarrow T^*M$ cotangent path-homotopic to a and b , respectively, such that the concatenation $a_1 \circ b_1$ is smooth.
- (iii) Choosing two other cotangent paths $a_2, b_2 : [0, 1] \rightarrow T^*M$ with the same properties, $a_1 \circ b_1$ and $a_2 \circ b_2$ are cotangent path-homotopic.

For the first part, one can obtain a cotangent path-homotopy between a and a^τ as the composition

$$T([0, 1] \times [0, 1]) \xrightarrow{d\psi} T[0, 1] \xrightarrow{a dt} T^*M,$$

where ψ is a path-homotopy between Id and τ ; for example,

$$\psi : [0, 1] \times [0, 1] \rightarrow [0, 1], \quad \psi(t, \varepsilon) := (1 - \varepsilon)t + \varepsilon \tau(t).$$

To prove (ii), we choose $\tau : [0, 1] \rightarrow [0, 1]$ which fixes the end points and all its positive derivatives vanish at the end points. Then the reparameterizations $a_1 := a^\tau$ and $b_1 := b^\tau$ are cotangent path-homotopic to a and b , and the concatenation $a_1 \circ b_1$ is smooth.

For (iii), since cotangent path-homotopy \sim is an equivalence relation (Lemma 10.19), we only need to check that if $a_0 \sim a_1$ and $b_0 \sim b_1$ and if the concatenations $a_0 \circ b_0$ and $a_1 \circ b_1$ are smooth, then $a_0 \circ b_0 \sim a_1 \circ b_1$. Consider cotangent path-homotopies Φ from a_0 to a_1 and Ψ from b_0 to b_1 , respectively. Fix a smooth map $\tau : [0, 1] \rightarrow [0, 1]$ which satisfies $\tau|_{[0, \frac{1}{3}]} = 0$ and $\tau|_{[\frac{2}{3}, 1]} = 1$. Then we have cotangent path-homotopies

$$\Phi^\tau := \Phi \circ d(\tau \times \text{Id}) \quad \text{and} \quad \Psi^\tau := \Psi \circ d(\tau \times \text{Id})$$

between $a_0^\tau \sim a_1^\tau$ and $b_0^\tau \sim b_1^\tau$. Consider the composition

$$\begin{aligned} \Phi^\tau \circ \Psi^\tau(t, \varepsilon) &:= \begin{cases} \Phi^\tau \circ d(2t, \varepsilon), & 0 \leq t \leq \frac{1}{2}, \\ \Psi^\tau \circ d(2t - 1, \varepsilon), & \frac{1}{2} < t \leq 1 \end{cases} \\ &= \begin{cases} 2\tau'(2t)\Phi_1(\tau(2t), \varepsilon)dt + \Phi_2(\tau(2t), \varepsilon)d\varepsilon, & 0 \leq t \leq \frac{1}{2}, \\ 2\tau'(2t - 1)\Psi_1(\tau(2t - 1), \varepsilon)dt + \Psi_2(\tau(2t - 1), \varepsilon)d\varepsilon, & \frac{1}{2} < t \leq 1. \end{cases} \end{aligned}$$

The properties of τ imply that $\Phi^\tau \circ \Psi^\tau(t, \varepsilon) = 0_x$ on the strip $[\frac{1}{3}, \frac{2}{3}] \times [0, 1]$; in particular, $\Phi^\tau \circ \Psi^\tau$ is smooth. Moreover, $\Phi^\tau \circ \Psi^\tau$ gives a cotangent path-homotopy $a_0^\tau \circ b_0^\tau \sim a_1^\tau \circ b_1^\tau$. We still need to show that $a_0^\tau \circ b_0^\tau \sim a_0 \circ b_0$

and $a_1^\tau \circ b_1^\tau \sim a_1 \circ b_1$. This follows from (i), because $a_0^\tau \circ b_0^\tau = (a_0 \circ b_0)^\sigma$ and $a_1^\tau \circ b_1^\tau = (a_1 \circ b_1)^\sigma$, where

$$\sigma(t) := \begin{cases} \frac{1}{2}\tau(2t), & 0 \leq t \leq \frac{1}{2}, \\ \frac{1}{2}(\tau(2t - 1) + 1), & \frac{1}{2} < t \leq 1. \end{cases}$$

This shows that the operation is well-defined. The proof that it defines a group structure follows similar arguments, and we leave it as an exercise. \square

Example 10.28 (Symplectic manifolds). Applying Exercise 10.20, one sees that for a symplectic manifold (M, π) the Poisson homotopy group $\Pi(M, \pi, x)$ coincides with the usual fundamental group $\pi_1(M, x)$.

Example 10.29 (Zero Poisson structures). Applying Exercise 10.21, one sees that for a manifold M equipped with the zero Poisson structure $\pi \equiv 0$, the Poisson homotopy group $\Pi(M, \pi, x)$ coincides with the cotangent space T_x^*M , viewed as an abelian group with addition.

Example 10.30 (Poisson homotopy group at zeros). Let (M, π) be a Poisson structure, and let $x \in M$ be a zero of π . We show that the Poisson homotopy at x depends only on the isotropy Lie algebra

$$\mathfrak{g} = \text{Ker } \pi_x = T_x^*M,$$

and we further identify it in terms of \mathfrak{g} .

First of all, a cotangent path at x is just a map $a : [0, 1] \rightarrow \mathfrak{g}$. Secondly, by Proposition 10.17, a cotangent homotopy between two cotangent paths at x amounts to a map

$$\Phi = \Phi_1 dt + \Phi_2 d\varepsilon : T([0, 1] \times [0, 1]) \rightarrow \mathfrak{g}$$

satisfying

$$(10.12) \quad \frac{d}{d\varepsilon} \Phi_1(t, \varepsilon) - \frac{d}{dt} \Phi_2(t, \varepsilon) = [\Phi_1(t, \varepsilon), \Phi_2(t, \varepsilon)]_{\mathfrak{g}},$$

$$(10.13) \quad \Phi_2(0, \varepsilon) = \Phi_2(1, \varepsilon) = 0.$$

Of course, (10.12) encodes precisely the fact that Φ is a Lie algebroid map. Notice that all conditions are stated solely in terms of the Lie algebra \mathfrak{g} . Hence, one obtains a purely Lie theoretical description of the Poisson homotopy group at x :

$$\Pi(M, \pi, x) \simeq \frac{\text{paths in } \mathfrak{g}}{\mathfrak{g}\text{-path-homotopy}}.$$

Here, by a **\mathfrak{g} -path-homotopy** we mean a map Φ satisfying (10.12) and (10.13).

To complete our discussion, recall that any Lie algebra \mathfrak{g} comes from a 1-connected Lie group, which is unique up to isomorphism. We will denote

this group by $\Pi(\mathfrak{g})$ and we show the following:

Proposition 10.31. *Let (M, π) be a Poisson manifold, let $x \in M$ be a zero of π , and let \mathfrak{g} be the isotropy Lie algebra at x . The Poisson homotopy group at x is isomorphic to the 1-connected Lie group with Lie algebra \mathfrak{g} :*

$$\Pi(M, \pi, x) \simeq \Pi(\mathfrak{g}).$$

Proof. Recall that $\Pi(\mathfrak{g})$ can be constructed out of any Lie group G integrating \mathfrak{g} by passing to its homotopy cover

$$\Pi(\mathfrak{g}) \simeq \frac{\text{paths in } G \text{ starting at } e}{\text{path-homotopy}}.$$

The group operation on $\Pi(\mathfrak{g})$ comes from pointwise multiplication of paths: if $g_1, g_2 : [0, 1] \rightarrow G$ are paths starting at e , then $g_1 \cdot g_2 : [0, 1] \rightarrow G$ is a new path starting at e . For the proof of the proposition we fix such a Lie group G and we will use the left invariant Maurer-Cartan form

$$\theta_G : TG \rightarrow \mathfrak{g}, \quad \theta_G(v) = dL_{g^{-1}}(v), \quad v \in T_g G.$$

The bijection between $\Pi(M, \pi, x)$ and $\Pi(\mathfrak{g})$ follows from the following lemma.

Lemma 10.32. (i) *The relation $a = \theta_G \circ dg$ gives a 1-to-1 correspondence*

$$\left\{ \begin{array}{l} \text{smooth paths} \\ g : [0, 1] \rightarrow G \\ \text{with } g(0) = e \end{array} \right\} \xleftrightarrow{\sim} \left\{ \begin{array}{l} \text{smooth paths} \\ a : [0, 1] \rightarrow \mathfrak{g} \end{array} \right\}.$$

(ii) *The relation $\Phi = \theta_G \circ dh$ gives a 1-to-1 correspondence*

$$\left\{ \begin{array}{l} \text{smooth path-homotopies} \\ h : [0, 1] \times [0, 1] \rightarrow G \\ \text{with } h(0, \varepsilon) = e \end{array} \right\} \xleftrightarrow{\sim} \left\{ \begin{array}{l} \mathfrak{g}\text{-path-homotopies} \\ \Phi : T([0, 1] \times [0, 1]) \rightarrow \mathfrak{g} \end{array} \right\}.$$

We will provide more geometric insight into these correspondences later in Example 13.81, which also contains another proof of this lemma.

Proof of Lemma 10.32. In order to show that the assignment (i) is bijective, we construct its inverse. Given $a : [0, 1] \rightarrow \mathfrak{g}$, the corresponding path $g : [0, 1] \rightarrow G$ is the solution to the ODE

$$\begin{cases} \frac{d}{dt}g(t) &= (d_e L_{g(t)})a(t), \\ g(0) &= e. \end{cases}$$

In other words, $g(t)$ is the integral curve starting at e of the left-invariant time-dependent vector field

$$\{X_t\}_{t \in [0,1]}, \quad X_t|_g := (d_e L_g)a(t).$$

The usual proof that left-invariant vector fields are complete also applies to time-dependent ones, and we conclude the $g(t)$ exists for all $t \in [0, 1]$.

Next, we show that the assignment in (ii) is well-defined. We observe that θ_G is a Lie algebroid map, because it pulls back forms on \mathfrak{g} to left-invariant forms on the Lie group G , and this pullback operations intertwines the Chevalley-Eilenberg differential with the de Rham differential — see Section A.1 — or else use Problem 9.17. Hence $\Phi = \theta_G \circ dh$ is a Lie algebroid map as well, and so (10.12) holds. Since h is a path-homotopy, we have that $\frac{\partial h}{\partial \varepsilon}(0, \varepsilon) = \frac{\partial h}{\partial \varepsilon}(1, \varepsilon) = 0$, and this implies that (10.13) also holds.

Finally, we construct an inverse to the assignment in (ii). Let $\Phi = \Phi_1 dt + \Phi_2 d\varepsilon$ be a \mathfrak{g} -path-homotopy. For each $\varepsilon \in [0, 1]$ we apply the inverse of (i) to each $a_\varepsilon := \Phi_1(\cdot, \varepsilon)$ to obtain a path $g_\varepsilon : [0, 1] \rightarrow G$ starting e . Let $h : [0, 1] \times [0, 1] \rightarrow G$, $h(t, \varepsilon) = g_\varepsilon(t)$. Then $\Phi' := \theta_G \circ dh$ is a Lie algebroid map of the form $\Phi' = \Phi'_1 dt + \Phi'_2 d\varepsilon$. We claim that $\Phi'_2 = \Phi_2$. First note that both satisfy the equation (10.12). In turn, that equation can be viewed as a family of ODEs in t , for each ε , the unknown being Φ_2 . Secondly, both Φ_2 and Φ'_2 satisfy the initial condition $\Phi_2(0, \varepsilon) = \Phi'_2(0, \varepsilon) = 0$, where the last equation follows from $\frac{\partial h}{\partial \varepsilon}(0, \varepsilon) = 0$. In conclusion $\Phi'_2 = \Phi_2$. In particular $\Phi_2(1, \varepsilon) = 0$ and, therefore, h is indeed a path-homotopy. \square

The lemma establishes a bijection between $\Pi(M, \pi, x)$ and $\Pi(\mathfrak{g})$ and we still have to take care of the compatibility with the group multiplication. This follows in two steps: given two paths $g_1, g_2 : [0, 1] \rightarrow G$ starting at e whose derivatives of any order vanish at the end points, one has the following:

- (i) The path $g_1 \cdot g_2$ is homotopic to the “shifted” concatenation:

$$(g_1 \circ g_2)(t) = \begin{cases} g_2(2t), & t \in [0, \frac{1}{2}], \\ g_1(2t - 1)g_2(1), & t \in (\frac{1}{2}, 1]. \end{cases}$$

- (ii) The map from item (i) of the lemma sends $g_1 \circ g_2$ to the concatenation $a_1 \circ a_2 : [0, 1] \rightarrow \mathfrak{g}$ of the \mathfrak{g} -paths corresponding to g_1 and g_2 , respectively.

This completes the proof of the proposition. \square

Exercise 10.33. Construct a path-homotopy justifying step (i) above. 

Determining the Poisson homotopy groups is in general a hard but often rewarding task: it may reveal some subtle properties of the Poisson manifold. We will see another example in the next section, where we treat the case of regular Poisson manifolds. Other examples will be discussed in later chapters. The relationship between the Poisson homotopy groups of a Poisson manifold and various types of submanifolds is discussed in the problems at the end of the chapter.

Related to the notion of cotangent path-homotopy, one has the notion of *cotangent homology*. For that, we call a **cotangent loop** in a Poisson manifold (M, π) any cotangent path $a : \mathbb{S}^1 \rightarrow T^*M$ defined on the circle.

Definition 10.34. Two cotangent loops $a_0, a_1 : \mathbb{S}^1 \rightarrow T^*M$ are called **cotangent homologous** if there exists a cotangent map $\Phi : T\Sigma \rightarrow T^*M$, defined on a compact oriented surface Σ whose boundary $\partial\Sigma$ consists of two circles, such that, up to a reparametrization,

$$\partial\Phi = a_0 \cup \bar{a}_1.$$

Remark 10.35. The definition implies that a cotangent loop a_0 is homologous to a constant loop $a_1 \equiv 0_x$ if and only if $a_0 = \partial\Phi$, where $\Phi : T\Sigma \rightarrow T^*M$ is a cotangent map from a compact oriented surface Σ with $\partial\Sigma$ consisting of a single circle. This can be proven by standard arguments.

We fix a point $e \in \mathbb{S}^1$ to be the **base point** of the circle. A cotangent loop $a : \mathbb{S}^1 \rightarrow T^*M$ is said to be **based** at $x \in M$ if its base loop sends e to x . The notion of cotangent homologous loops leads to the following definition:

Definition 10.36. The **degree 1 Poisson homology group** of (M, π) with base point $x \in M$ is the group

$$H_1^\pi(M, x) := \frac{\text{cotangent loops based at } x}{\text{cotangent homologous}},$$

with the group operation characterized by

$$[[a]] \cdot [[b]] = [[a \circ b]],$$

for any cotangent loops a and b with the property that $a \circ b$ is smooth.

Remark 10.37. The group in Definition 10.36 should not be confused with the group from Problem 9.13, which consists of equivalence classes of 1-forms. The terminology in Problem 9.13 was chosen for historical reasons.

A proof similar to that for the Poisson homotopy group shows that the operation in Definition 10.36 is well-defined and is a group product.

As an interesting application of Stokes’s Theorem, we obtain:

Corollary 10.38. *For a Poisson manifold (M, π) , there is a pairing between the first Poisson homology group at x and the first Poisson cohomology group*

$$\int : H_1^\pi(M, x) \times H_\pi^1(M) \rightarrow \mathbb{R}, \quad ([[a]], [X]) \mapsto \int_a X.$$

Since two cotangent loops that are path-homotopic are also cotangent homologous, we have a surjective homomorphism

$$H : \Pi(M, \pi, x) \rightarrow H_1^\pi(M, x), \quad [a] \mapsto \llbracket a \rrbracket$$

which we call the **Hurewicz homomorphism**.

We also have the following version of the Hurewicz Theorem, which shows in particular that the Poisson homology group $H_1^\pi(M, x)$ is always abelian:

Theorem 10.39 (Contreras and Fernandes [36]). *Let (M, π) be a Poisson manifold. The kernel of the Hurewicz homomorphism $H : \Pi(M, \pi, x) \rightarrow H_1^\pi(M, x)$ is the commutator subgroup, so we have a group isomorphism*

$$H_1^\pi(M, x) \simeq \frac{\Pi(M, \pi, x)}{(\Pi(M, \pi, x), \Pi(M, \pi, x))}.$$

Proof. We will work only with cotangent loops a, b that vanish with all their derivatives at the base point, so that the composition $a \circ b$ is smooth — recall Lemma 10.4 and the proof of Lemma 10.27.

We start by showing that $H_1^\pi(M, x)$ is an abelian group, i.e., that for any two cotangent loops $a_1, a_2 : \mathbb{S}^1 \rightarrow T^*M$ based at $x \in M$, $a_1 \circ a_2$ and $a_2 \circ a_1$ are cotangent homologous. This is equivalent to the commutator

$$a : \mathbb{S}^1 \rightarrow T^*M, \quad a := (a_1, a_2) = a_1 \circ a_2 \circ a_1^{-1} \circ a_2^{-1},$$

being cotangent homologous to the trivial cotangent loop 0_x .

We identify $\mathbb{S}^1 \simeq \partial(I \times I)$, where $I = [0, 1]$, we let $D \subset \text{int}(I \times I)$ be a closed disk, and we set

$$\Sigma' = (I \times I) \setminus D.$$

If we let $\phi : \Sigma' \rightarrow \partial(I \times I)$ be a retraction of Σ' to the boundary $\partial(I \times I)$, we obtain a cotangent map

$$\Phi' := a \circ d\phi : T\Sigma' \rightarrow T^*M,$$

defining a cotangent homotopy between a and $a' := \Phi'|_{T(\partial D)}$ — see Figure 10.1.

If we now glue the opposite sides of the square $\partial(I \times I)$, we obtain a surface with boundary Σ and the retraction can be chosen so that Φ' induces a cotangent map $\Phi : T\Sigma \rightarrow T^*M$, showing that a is cotangent homologous to 0_x .

Since $H_1^\pi(M, x)$ is an abelian group, an element in the commutator subgroup $(\Pi(M, \pi, x), \Pi(M, \pi, x))$ belongs to the kernel of the Hurewicz homomorphism $H : \Pi(M, \pi, x) \rightarrow H_1^\pi(M, x)$. So we are left to show that,

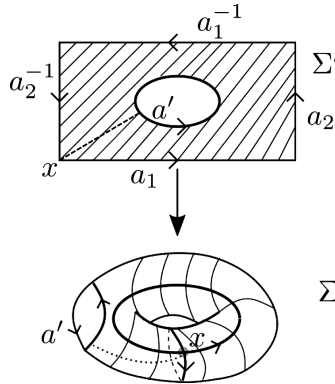

Figure 10.1. The cotangent loops $a_1 \circ a_2$ and $a_2 \circ a_1$ are homologous

conversely, if a cotangent loop $a : \mathbb{S}^1 \rightarrow T^*M$ based at x is in the kernel of H , then a is cotangent path-homotopic to a product of commutators of cotangent loops.

By Remark 10.35, there exists a compact, oriented surface Σ with boundary $\partial\Sigma \simeq \mathbb{S}^1$ and a cotangent map $\Phi : T\Sigma \rightarrow T^*M$ such that $\partial\Phi = a$. This equality involves a parametrization $\delta : \mathbb{S}^1 \xrightarrow{\sim} \partial\Sigma$, which is based at $e \in \partial\Sigma$, the base point that maps to x . Since Σ is compact, it can be obtained by gluing the sides of a polygon Δ with $4g + 1$ sides, where g is the genus of Σ . More precisely, there exists a smooth parametrization $\psi : \Delta \rightarrow \Sigma$, which sends the sides of Δ to

$$\delta^{-1}, \gamma_1, \eta_1, \gamma_1^{-1}, \eta_1^{-1}, \dots, \gamma_g, \eta_g, \gamma_g^{-1}, \eta_g^{-1},$$

in this order, where $\gamma_i, \eta_i : \mathbb{S}^1 \rightarrow \Sigma$ are loops based at e . Hence, $a_i := \Phi \circ d\gamma_i$ and $b_i := \Phi \circ d\eta_i$ are cotangent loops based at x , and $\Phi \circ d\psi$ is a cotangent path-homotopy between $a = \Phi \circ d\delta$ and the concatenation

$$a_1 \circ b_1 \circ a_1^{-1} \circ b_1^{-1} \circ \dots \circ a_g \circ b_g \circ a_g^{-1} \circ b_g^{-1}.$$

This means that

$$a \sim (a_1, b_1) \cdots (a_g, b_g),$$

and the result follows. □

As shown in the examples above, the Poisson homotopy/homology groups can be quite different at distinct points of M . However, the groups at points in the same leaf are isomorphic.

Corollary 10.40. *Let x, y belong to the same symplectic leaf S of (M, π) , and let $a : [0, 1] \rightarrow T^*M$ be a cotangent path connecting them. Then there is*

a group isomorphism

$$c_a : \Pi(M, \pi, x) \xrightarrow{\simeq} \Pi(M, \pi, y), \quad [b] \mapsto [a \circ b \circ \bar{a}]$$

which depends only on the path-homotopy class of a .

Moreover, c_a induces a group isomorphism

$$c_a : H_1^\pi(M, x) \xrightarrow{\simeq} H_1^\pi(M, y),$$

which does not depend on a . So all Poisson homology groups over the same leaf are canonically isomorphic.

We leave the proof as an exercise.

10.6. Variation of symplectic area

We will see now how the Poisson homotopy groups codify geometric information about the *transverse behavior* of a Poisson manifold. For now, we will consider only regular Poisson manifolds. In later chapters, we will be able to consider the nonregular case.

As in Example 10.22, we start with a simple foliation $M = S \times \mathbb{R}^q$ with symplectic leaves,

$$S_y = S \times \{y\}, \quad y \in \mathbb{R}^q,$$

and denote the symplectic form on S_y by $\omega_y \in \Omega^2(S_y)$. We denote by

$$\omega \in \Omega^2(M)$$

the unique extension of the leafwise symplectic structure which vanishes on the second factor of $TM = TS \oplus T\mathbb{R}^q$.

We define a map which measures the transverse variation of the symplectic area of 2-spheres as follows. Consider a 2-sphere $\sigma : \mathbb{S}^2 \rightarrow S_y$, mapping the north pole p_N to $x = (s, y)$. Denote the normal space at x by

$$\nu_x(S_y) := T_x M / T_x S_y \simeq \mathbb{R}^q.$$

Given a normal vector $v \in \nu_x(S_y) \simeq \mathbb{R}^q$, consider the curve

$$x_t := (s, y_t) := (s, y + tv), \quad t \in [0, 1],$$

and consider the family of 2-spheres

$$\sigma_t : \mathbb{S}^2 \rightarrow S_{y_t}, \quad \sigma_t(u) := (\sigma(u), y_t)$$

mapping p_N to x_t . So we have deformed the initial 2-sphere σ lying in S_y in the normal direction v to a family of 2-spheres σ_t , each lying in a symplectic leaf S_{y_t} . We can compute the symplectic areas of these 2-spheres and we

find the following:

Lemma 10.41. *The assignment*

$$\nu_x(S_y) \ni v \mapsto \frac{d}{dt} \Big|_{t=0} \int_{\sigma_t} \omega_{y_t}$$

only depends on the class $[\sigma] \in \pi_2(S_y, x)$ and is a linear function of v .

Proof. Let σ^ε be a homotopy of 2-spheres in S_y (relative to x). For each t , its deformation $\sigma_t^\varepsilon : \mathbb{S}^2 \rightarrow S_{y_t}$ in the normal direction v gives a homotopy of 2-spheres in S_{y_t} (relative to x_t). Since $\omega_{y_t} \in \Omega^2(S_{y_t})$ is closed, it follows that the integral

$$I := \int_{\sigma_t^\varepsilon} \omega_{y_t} = \int_{\sigma} \omega_{y+tv}$$

is independent of ε . Hence, we have a function $I = I(tv)$ independent of ε and its derivative at $t = 0$ is a linear function of v . □

The lemma shows that the following is well-defined.

Definition 10.42. The **variation of symplectic area** at $x = (s, y)$ is the map

$$A'_x : \pi_2(S_y, x) \rightarrow \nu_x^*(S_y), \quad \langle A'_x(\sigma), v \rangle = \frac{d}{dt} \Big|_{t=0} \int_{\sigma_t} \omega_{y_t}.$$

Example 10.43. For a linear family of symplectic structures

$$\omega_y = \omega_0 + y^1 \omega_1 + \cdots + y^q \omega_q, \quad \omega_i \in \Omega_{cl}^2(S),$$

the variation of symplectic area at $x = (s, 0)$ is given by

$$A'_x : \pi_2(S_0, x) \rightarrow \mathbb{R}^q, \quad [\sigma] \mapsto \left(\int_{\sigma} \omega_1, \dots, \int_{\sigma} \omega_q \right).$$

The Poisson homotopy groups can be described using this map:

Theorem 10.44. *For the Poisson manifold $M = S \times \mathbb{R}^q$ with symplectic foliation $\{(S_y, \omega_y) : y \in \mathbb{R}^q\}$ and for any $x = (s, y) \in M$, there is short exact sequence of groups*

$$1 \longrightarrow \nu_x^*(S_y)/\mathcal{N}_x \longrightarrow \Pi(M, \pi, x) \longrightarrow \pi_1(S_y, x) \longrightarrow 1$$

where

$$\mathcal{N}_x = \{A'_x(\sigma) \in \nu_x^*(S_y) : [\sigma] \in \pi_2(S_y, x)\}.$$

In particular, if S_y is simply connected, we have $\Pi(M, \pi, x) \simeq \nu_x^(S_y)/\mathcal{N}_x$.*

Proof. First, we have the group homomorphism

$$p : \Pi(M, \pi, x) \rightarrow \pi_1(S_y, x), \quad [a] \mapsto [\gamma_a],$$

which to a cotangent homotopy class of a cotangent path $a : [0, 1] \rightarrow T^*M$ associates the homotopy class of its base path $\gamma_a : [0, 1] \rightarrow S_y$.

Next, we observe that since $\nu_x^*(S_y) = \text{Ker } \pi_x^\sharp$, any element $\alpha \in \nu_x^*(S_y)$ defines a constant cotangent path $a(t) = \alpha$. Hence, we have another group homomorphism

$$q : \nu_x^*(S_y) \rightarrow \Pi(M, \pi, x), \quad \alpha \mapsto [\alpha].$$

We leave it as exercise to check that this is a group homomorphism:

Exercise 10.45. For $\alpha_1, \alpha_2 \in \text{Ker } \pi_x^\sharp$ show that the constant cotangent paths $a_1(t) = \alpha_1$ and $a_2(t) = \alpha_2$ satisfy $[a_1] \cdot [a_2] = [a]$, where $a(t) = \alpha_1 + \alpha_2$.

Next, let us verify that the sequence from the statement is exact:

- $\text{Im } q \subset \text{Ker } p$: This follows from the definition.
- $\text{Im } p = \pi_1(S_y, x)$: This follows because every path in a symplectic leaf is the base path of some cotangent path.
- $\text{Ker } p \subset \text{Im } q$: Let $[a_0]$ be in the kernel of $p : \Pi(M, \pi, x) \rightarrow \pi_1(S_y, x)$. This means that $a_0 : [0, 1] \rightarrow T^*M$ is a cotangent loop based at x whose base path is contractible. Denoting the base homotopy by $\gamma(t, \varepsilon)$, it follows from Example 10.22 that there exists a cotangent path-homotopy from $a_0(t)$ to the constant cotangent path $a_1(t) = \alpha \in \nu_x^*(S_y) \simeq (\mathbb{R}^q)^*$, where (see (10.10))

$$\alpha = \int_0^1 f_0(t) dt - \int_0^1 \int_0^1 d\omega\left(\frac{\partial \gamma}{\partial t}, \frac{\partial \gamma}{\partial \varepsilon}, -\right) dt d\varepsilon$$

and $a_0(t) = (\frac{\partial \gamma}{\partial t}(t, 0), f_0(t))$, w.r.t. the isomorphism (10.9). Hence, we have that $[a_0] = [\alpha]$ is in the image of $q : \nu_x^*(S_y) \rightarrow \Pi(M, \pi, x)$.

- $\text{Ker } q = \mathcal{N}_x$: Assume that $\alpha \in \nu_x^*(S_y)$ is an element in the kernel of q ; i.e., $\alpha \sim 0$. By Example 10.22, a cotangent path-homotopy from α to 0_x ,

$$\Phi = \Phi_1(t, \varepsilon) dt + \Phi_2(t, \varepsilon) d\varepsilon,$$

has components $\Phi_1(t, \varepsilon) = (\frac{\partial \sigma}{\partial t}, f(t, \varepsilon))$, $\Phi_2(t, \varepsilon) = (\frac{\partial \sigma}{\partial \varepsilon}, g(t, \varepsilon))$, where σ is the base homotopy and

$$\int_0^1 f(t, 0) dt - \int_0^1 f(t, 1) dt = \int_0^1 \int_0^1 d\omega\left(\frac{\partial \sigma}{\partial t}, \frac{\partial \sigma}{\partial \varepsilon}, -\right) dt d\varepsilon.$$

Since $f(t, 0) = \alpha$ and $f(t, 1) = 0_x$, we conclude that

$$\langle \alpha, w \rangle = \left\langle \int_0^1 \alpha dt, w \right\rangle = \int_0^1 \int_0^1 d\omega\left(\frac{\partial \sigma}{\partial t}, \frac{\partial \sigma}{\partial \varepsilon}, w\right) dt d\varepsilon = \int_\sigma i_w d\omega.$$

Since $\sigma(t, \varepsilon)$ satisfies $\sigma(t, 0) = \sigma(t, 1) = \sigma(0, \varepsilon) = \sigma(1, \varepsilon) = x$, it defines an element $[\sigma] \in \pi_2(S_y, x)$. It remains to show the following:

Lemma 10.46. *If $\sigma_t : \mathbb{S}^2 \rightarrow S_{y_t}$ is a deformation of $\sigma : \mathbb{S}^2 \rightarrow S_y$ in the direction $w \in \nu_x(S_y) \simeq \mathbb{R}^q$, then*

$$\int_{\sigma} i_w d\omega = \langle A'_x(\sigma), w \rangle = \left. \frac{d}{dt} \right|_{t=0} \int_{\sigma_t} \omega_{y_t}.$$

Proof of the lemma. Observe that $\sigma_t = \phi_w^t \circ \sigma$, where ϕ_w^t is the flow of the constant vector field $(0, w) \in TS \oplus T\mathbb{R}^q$. Hence, we have

$$\begin{aligned} \left. \frac{d}{dt} \right|_{t=0} \int_{\sigma_t} \omega_{y_t} &= \left. \frac{d}{dt} \right|_{t=0} \int_{\mathbb{S}^2} \sigma_t^* \omega \\ &= \left. \frac{d}{dt} \right|_{t=0} \int_{\mathbb{S}^2} \sigma^* (\phi_w^t)^* \omega \\ &= \left. \frac{d}{dt} \right|_{t=0} \int_{\sigma} (\phi_w^t)^* \omega \\ &= \int_{\sigma} \mathcal{L}_w \omega = \int_{\sigma} i_w d\omega, \end{aligned}$$

where we used in the first line that $\omega|_{\sigma_t} = \omega_{y_t}$ and in the last line that $i_w \omega = 0$. This completes the proof of the lemma and, hence, also of the theorem. □

Example 10.47. Consider the regular Poisson manifold $(M = S \times \mathbb{R}_+, \pi)$, where $S = \mathbb{S}^2 \times \mathbb{S}^2$ and the leafwise symplectic form is given by

$$\omega_y := y(\text{pr}_1^* \omega_{\mathbb{S}^2} + \lambda \text{pr}_2^* \omega_{\mathbb{S}^2}),$$

where $\omega_{\mathbb{S}^2}$ is a symplectic form on the sphere of area 1 and λ is some fixed nonzero real number. Then $\pi_2(S) \simeq \mathbb{Z} \times \mathbb{Z}$ where the generators $(1, 0)$ and $(0, 1)$ can be represented by the inclusions $\mathbb{S}^2 \hookrightarrow \mathbb{S}^2 \times \mathbb{S}^2$, $s \mapsto (s, p_N)$, and $s \mapsto (p_N, s)$. Also, $\nu_x^*(S_y) \simeq \mathbb{R}$. The variation of symplectic area at $x \in M$ is the map (see Example 10.43)

$$A'_x : \mathbb{Z} \times \mathbb{Z} \rightarrow \mathbb{R}, \quad (n_1, n_2) \mapsto n_1 + \lambda n_2.$$

Hence, at any $x \in M$, $\mathcal{N}_x = \mathbb{Z} + \lambda\mathbb{Z}$ and the Poisson homotopy group is

$$\Pi(M, \pi, x) \simeq \mathbb{R}/(\mathbb{Z} + \lambda\mathbb{Z}).$$

Depending on whether λ is rational or not, this group is either isomorphic to \mathbb{S}^1 or not (e.g., compare elements of order 2). In the latter case, the group is a non-Hausdorff topological group — see also Problem 10.12. 

For a general regular Poisson manifold the situation is similar to the case discussed above. The details are given in [42] and the main points are as follows:

- Given a 2-sphere $\sigma : \mathbb{S}^2 \rightarrow S$ in a symplectic leaf S based at x and a normal vector $v \in \nu_x(S)$, one can find a smooth deformation of 2-spheres $\sigma_t : \mathbb{S}^2 \rightarrow S_t$ in the leaf S_t based at some point x_t starting at $\sigma_0 = \sigma$ and such that $v = \frac{d}{dt}x_t|_{t=0}$.
- As in Lemma 10.41, the assignment

$$\nu_x(S_y) \ni v \mapsto \frac{d}{dt} \Big|_{t=0} \int_{\sigma_t} \omega_{S_t}$$

only depends on the class $[\sigma] \in \pi_2(S, x)$ and is linear in v .

Hence, for an arbitrary regular Poisson manifold, one defines the **variation of symplectic area** at x to be the group homomorphism

$$A'_x : \pi_2(S, x) \rightarrow \nu_x^*(S), \quad \langle A'_x(\sigma), v \rangle = \frac{d}{dt} \Big|_{t=0} \int_{\sigma_t} \omega_{S_t},$$

where σ_t is any deformation of σ in the normal direction v .

The theorem remains valid in this general case *mutatis mutandis*:

Theorem 10.48. *Given a regular Poisson manifold (M, π) and a point $x \in M$ belonging to the symplectic leaf S , there is a short exact sequence*

$$1 \longrightarrow \nu_x^*(S)/\mathcal{N}_x \longrightarrow \Pi(M, \pi, x) \longrightarrow \pi_1(S, x) \longrightarrow 1,$$

where \mathcal{N}_x is the image of the variation of symplectic area map A'_x

$$\mathcal{N}_x = \{A'_x(\sigma) \in \nu_x^*(S) : [\sigma] \in \pi_2(S, x)\}.$$

In particular, if the leaf S is simply connected, then $\Pi(M, \pi, x) \simeq \nu_x^(S)/\mathcal{N}_x$.*

Problems

10.1. Let $(A, [\cdot, \cdot]_A, \rho)$ be a Lie algebroid. Define a general notion of A -path and A -path-homotopy between A -paths so that the following hold:

- (a) When $A = TM$, for an arbitrary manifold M , one recovers the usual notion of smooth path and smooth path-homotopy.
- (b) When $A = T^*M$, for a Poisson manifold (M, π) , one recovers the notion of cotangent path and cotangent path-homotopy.

10.2. Prove Proposition 10.12.

10.3. Let (M, π) be an exact Poisson manifold. Show that if S is a compact symplectic leaf of (M, π) which is not a point, then there is no cotangent map $\Phi : TS \rightarrow T^*M$ covering the inclusion $S \hookrightarrow M$.

10.4. Let (M, π) be a Poisson manifold. For a vector bundle map $\Phi : T\Sigma \rightarrow T^*M$ show the following:

- (a) If $\Phi^*d\pi = d\Phi^*$ holds on $C^\infty(M)$ and $\mathfrak{X}^1(M)$, then Φ is a cotangent map.
 (b) If for any smooth square $\psi : [0, 1] \times [0, 1] \rightarrow \Sigma$ the composition $\Phi \circ d\psi : T([0, 1] \times [0, 1]) \rightarrow T^*M$ is a cotangent map, then Φ is a cotangent map.

10.5. Let (M, π) be a Poisson manifold, and let $x \in M$. Show that the product on $\Pi(M, \pi, x)$ defined in (10.11) is indeed a group multiplication.

10.6. Prove Corollary 10.40.

10.7. Let (M, π) be a Poisson manifold, and let $\Phi : T\Sigma \rightarrow T^*M$ be a cotangent map covering a map $\phi : \Sigma \rightarrow M$.

- (a) Show that for any smooth path $\gamma : [0, 1] \rightarrow \Sigma$ the map

$$\Phi_*(\gamma) := \Phi \circ \frac{d\gamma}{dt} : [0, 1] \rightarrow T^*M$$

defines a cotangent path with base path $\phi \circ \gamma : I \rightarrow M$.

- (b) Prove that if $\gamma_0, \gamma_1 : [0, 1] \rightarrow \Sigma$ are path-homotopic, then $\Phi_*(\gamma_0)$ and $\Phi_*(\gamma_1)$ are cotangent path-homotopic.
 (c) Show that the resulting map

$$\Phi_* : \pi_1(\Sigma, x) \rightarrow \Pi(M, \pi, \phi(x))$$

is a group homomorphism.

10.8. Let $\omega_{\mathbb{S}^2} \in \Omega^2(\mathbb{S}^2)$ be the standard area form. On the manifold $M = \mathbb{S}^2 \times \mathbb{S}^2 \times \mathbb{R}^2$ consider a regular Poisson structure π with symplectic leaves

$$S_y = \mathbb{S}^2 \times \mathbb{S}^2 \times \{y\}, \quad y = (y_1, y_2) \in \mathbb{R}^2,$$

and foliated symplectic form

$$\omega_{(y_1, y_2)} = f(y_1) \text{pr}_1^* \omega_{\mathbb{S}^2} + g(y_2) \text{pr}_2^* \omega_{\mathbb{S}^2},$$

where $f, g \in C^\infty(\mathbb{R})$ are two positive smooth functions. Using Theorem 10.44, find the Poisson homotopy groups of (M, π) .

10.9. Let (M, π) be a Poisson manifold, and let $(P, \pi_P) \hookrightarrow (M, \pi)$ be a complete Poisson submanifold. Denote the restriction map on covectors by

$$p : T_P^*M \rightarrow T^*P.$$

Show that, for any $x \in P$, there is a surjective homomorphism of Poisson homotopy groups

$$p_* : \Pi(M, \pi, x) \rightarrow \Pi(P, \pi_P, x).$$

In particular, conclude that for any symplectic leaf $i : S \hookrightarrow M$ through a point x , we have a surjective group homomorphism

$$p_* : \Pi(M, \pi, x) \rightarrow \pi_1(S, x), \quad [a] \mapsto [\gamma_a].$$

10.10. Let (M, π) be a Poisson manifold, and let (X, π_X) be a Poisson transversal. Consider the inclusion map

$$i : T^*X \hookrightarrow T_X^*M$$

induced by the decomposition $T_X M = TX \oplus (TX)^\perp$. Show that, for any $x \in X$, there is an induced group homomorphism

$$i_* : \Pi(X, \pi_X, x) \rightarrow \Pi(M, \pi, x).$$

Assuming now that (M, π) is regular, let S be the symplectic leaf through $x \in M$, and let $X \subset M$ be a small enough slice through x . Using Theorem 10.48, describe the map i_* in this case. In particular, show the following:

- (a) i_* is surjective $\Leftrightarrow \pi_1(S, x) = 0$.
- (b) i_* is injective $\Leftrightarrow A'_x = 0$.

10.11. Let $(N, \pi_N) \hookrightarrow (M, \pi)$ be a coregular Poisson-Dirac submanifold. Consider the Lie algebroid from Problem 9.16:

$$A_N := (TN^\perp)^\circ = \{\alpha \in T_N^*M : \pi^\sharp(\alpha) \in TN\}.$$

Making use of Problem 10.1, define the relative homotopy groups

$$\Pi(M, N, \pi, x) = \frac{A_N\text{-loops based at } x}{A_N\text{-path-homotopies}}.$$

Denoting by $i : A_N \rightarrow T^*M$ and $p : A_N \rightarrow T^*N$ the inclusion and the restriction maps, show the following:

- (a) i induces a group homomorphism

$$i_* : \Pi(M, N, \pi, x) \rightarrow \Pi(M, \pi, x),$$

which generalizes the map from Problem 10.10.

- (b) p induces a surjective group homomorphism

$$p_* : \Pi(M, N, \pi, x) \rightarrow \Pi(N, \pi_N, x),$$

which generalizes the map from Problem 10.9.

10.12. If (M, π) is a Poisson manifold, the space of cotangent paths in M has a natural C^0 -topology. We endow the Poisson homotopy group $\Pi(M, \pi, x)$ with the quotient topology. Show that this makes $\Pi(M, \pi, x)$ into a topological group — i.e., the group laws are continuous — and that the connected component of the identity element is precisely the kernel of the group homomorphism $\Pi(M, \pi, x) \rightarrow \pi_1(S, x)$, where S is the leaf through x .

Contravariant Geometry and Connections

11.1. Contravariant connections on vector bundles

Following once again the point of view that in Poisson geometry the correct tangent bundle is the cotangent Lie algebroid, one is led to the following notion of connection:

Definition 11.1. Let (M, π) be a Poisson manifold, and let $E \rightarrow M$ be a vector bundle. A **contravariant connection** on E is an \mathbb{R} -bilinear operation

$$\Omega^1(M) \times \Gamma(E) \rightarrow \Gamma(E), \quad (\alpha, s) \mapsto \nabla_\alpha s,$$

satisfying the following properties:

$$\nabla_{f\alpha} s = f \nabla_\alpha s, \quad \nabla_\alpha (fs) = f \nabla_\alpha s + \mathcal{L}_{\pi^\# \alpha}(f)s.$$

We will call a pair (E, ∇) a **contravariant vector bundle**.

Given a local chart (U, x^1, \dots, x^n) where E admits a basis of sections $\{e^1, \dots, e^r\}$, a contravariant connection is determined locally by some functions $\Gamma_k^{il} \in C^\infty(U)$, called the **Christoffel symbols**

$$(11.1) \quad \nabla_{dx^i} e^l = \sum_{k=1}^r \Gamma_k^{il} e^k \quad (1 \leq i \leq n, 1 \leq l \leq r).$$

Exercise 11.2. For a contravariant connection ∇ on E , given a section $s \in \Gamma(E)$, show that $\nabla_\alpha s|_x$ depends only on $\alpha|_x \in T_x^*M$. Deduce that any $\xi \in T^*M$ defines a map $\nabla_\xi : \Gamma(E) \rightarrow \mathbb{R}$.

Many of the usual constructions for ordinary connections extend to contravariant connections in a more or less straightforward way. For example, the **curvature** of a contravariant connection ∇ on E is the $\text{End}(E)$ -valued bivector field given by

$$R_\nabla \in \mathfrak{X}^2(M; \text{End}(E)) := \Gamma\left(\bigwedge^2 TM \otimes \text{End}(E)\right),$$

$$R_\nabla(\alpha, \beta)s := \nabla_\alpha(\nabla_\beta s) - \nabla_\beta(\nabla_\alpha s) - \nabla_{[\alpha, \beta]_\pi} s,$$

for all $\alpha, \beta \in \Omega^1(M)$ and $s \in \Gamma(E)$. The connection is said to be **flat** if its curvature vanishes identically.

Exercise 11.3. Show that the formula above for the curvature defines indeed a section of the vector bundle $\bigwedge^2 TM \otimes \text{End}(E)$.

Example 11.4. Let $E \rightarrow M$ be a vector bundle with an ordinary connection $\overline{\nabla}$. If the base is a Poisson manifold (M, π) , we can produce a contravariant connection ∇ on E by setting

$$\nabla_\alpha s = \overline{\nabla}_{\pi^\sharp(\alpha)} s.$$

The curvature tensors $R_{\overline{\nabla}}$ and R_∇ of $\overline{\nabla}$ and ∇ are related by

$$R_\nabla(\alpha, \beta) = R_{\overline{\nabla}}(\pi^\sharp(\alpha), \pi^\sharp(\beta)).$$

Although this gives a quick way of producing contravariant connections, these connections do not play a significant role in Poisson geometry. 

Example 11.5 (Pullback connections). Let $\Phi : T\Sigma \rightarrow T^*M$ be a cotangent map into a Poisson manifold (M, π) , covering a map $\phi : \Sigma \rightarrow M$. Given a vector bundle $p : E \rightarrow M$ with a contravariant connection ∇ , the pullback vector bundle

$$\phi^*E = \{(u, x) : p(u) = \phi(x)\}$$

has an induced ordinary connection $\overline{\nabla} = \Phi^*\nabla$, uniquely determined by the condition

$$\overline{\nabla}_v(\phi^*s) = \nabla_{\Phi(v)} s \quad (v \in T_x\Sigma, s \in \Gamma(E)).$$

That this is well-defined uses only the first property of contravariant maps: $\pi^\sharp \circ \Phi = d\phi$, Lemma 10.6. The full condition implies that $R_{\overline{\nabla}} = \Phi^*R_\nabla$; i.e.,

$$R_{\overline{\nabla}}(v, w) = R_\nabla(\Phi(v), \Phi(w)) \quad (v, w \in T_x\Sigma).$$

In particular, one can pull back connections along cotangent paths. 

Example 11.6. Let (M, π) be a regular Poisson structure and consider the conormal bundle to the symplectic foliation

$$\nu^*(\mathcal{F}_\pi) := (T\mathcal{F}_\pi)^\circ = \text{Ker } \pi^\sharp.$$

We have a canonical contravariant connection

$$\nabla_\alpha \beta := [\alpha, \beta]_\pi, \quad \alpha \in \Omega^1(M), \beta \in \Gamma(\nu^*(\mathcal{F}_\pi)),$$

called the **contravariant Bott connection**. The Jacobi identity implies flatness: $R_\nabla \equiv 0$. Recall that the usual Bott connection $\bar{\nabla}$ on $\nu^*(\mathcal{F}_\pi)$ is the partial connection

$$\bar{\nabla}_X \beta = \mathcal{L}_X \beta, \quad X \in \mathfrak{X}(\mathcal{F}_\pi), \beta \in \Gamma(\nu^*(\mathcal{F}_\pi)).$$

Using the expression for $[\cdot, \cdot]_\pi$ one sees that the two are related by

$$\nabla_\alpha \beta = \bar{\nabla}_{\pi^\sharp(\alpha)} \beta.$$

Example 11.7. Let (M, π) be a Poisson manifold. The line bundle $\bigwedge^{\text{top}} T^*M$ carries a canonical contravariant connection ∇ . This is defined on exact 1-forms by

$$\nabla_{df} \mu := \mathcal{L}_{X_f} \mu, \quad f \in C^\infty(M), \mu \in \Omega^{\text{top}}(M),$$

and it is extended to all 1-forms by requiring $C^\infty(M)$ -linearity. Using that $[df_1, df_2]_\pi = d\{f_1, f_2\}$, we see that this connection is flat:

$$R_\nabla(df_1, df_2)\mu = \mathcal{L}_{X_{f_1}}(\mathcal{L}_{X_{f_2}}\mu) - \mathcal{L}_{X_{f_2}}(\mathcal{L}_{X_{f_1}}\mu) - \mathcal{L}_{X_{\{f_1, f_2\}}}\mu = 0. \quad \text{🐟}$$

Let $L \rightarrow M$ be a line bundle over a Poisson manifold (M, π) equipped with a flat contravariant connection ∇ . Assume first that L has a nowhere vanishing section μ , so L is actually trivial. Then

$$(11.2) \quad \nabla_\alpha \mu = c_\mu(\alpha)\mu,$$

for some C^∞ -linear map $c_\mu : \Omega^1(M) \rightarrow C^\infty(M)$, i.e., a vector field $c_\mu \in \mathfrak{X}(M)$. Since we assume the connection to be flat, we find that

$$\begin{aligned} 0 &= \nabla_\alpha \nabla_\beta \mu - \nabla_\beta \nabla_\alpha \mu - \nabla_{[\alpha, \beta]}\mu \\ &= \nabla_\alpha(c_\mu(\beta)\mu) - \nabla_\beta(c_\mu(\alpha)\mu) - c_\mu([\alpha, \beta])\mu \\ &= (\mathcal{L}_{\pi^\sharp(\alpha)}c_\mu(\beta))\mu - (\mathcal{L}_{\pi^\sharp(\beta)}c_\mu(\alpha))\mu - c_\mu([\alpha, \beta])\mu \\ &= (d_\pi c_\mu)(\alpha, \beta)\mu. \end{aligned}$$

We conclude that c_μ is a Poisson vector field: $d_\pi c_\mu = 0$.

Exercise 11.8. If $\mu' = \pm e^g \mu$ is another nowhere vanishing section, show that

$$c_{\mu'} = c_\mu - X_g;$$

i.e., $c_{\mu'}$ and c_μ differ by a Hamiltonian vector field.

It follows that the Poisson cohomology class

$$c(L, \nabla) := [c_\mu] \in H^1_\pi(M)$$

does not depend on the choice of μ .

When L is not trivializable, we can still define $c(L, \nabla)$ as follows. Form the tensor product $L^{\otimes 2} = L \otimes L$ and equip it with the flat connection

$$\tilde{\nabla}_\alpha(\mu \otimes \xi) := \nabla_\alpha \mu \otimes \xi + \mu \otimes \nabla_\alpha \xi.$$

Since $L^{\otimes 2}$ has a nowhere vanishing section, we can define

$$c(L, \nabla) := \frac{1}{2}[c(L^{\otimes 2}, \tilde{\nabla})] \in H^1_\pi(M).$$

Exercise 11.9. If L is trivializable, the two definitions of $c(L, \nabla)$ agree.

Definition 11.10. Let (M, π) be a Poisson manifold, and let $L \rightarrow M$ be a line bundle with a flat contravariant connection ∇ . The Poisson cohomology class $c(L, \nabla) \in H^1_\pi(M)$ is called the **characteristic class** of (L, ∇) .

Example 11.11 (Modular class). We saw in Example 11.7 that, for any Poisson manifold (M, π) , the line bundle $\bigwedge^{\text{top}} T^*M$ carries a canonical flat connection. Hence, we have a characteristic class

$$c\left(\bigwedge^{\text{top}} T^*M, \nabla\right) \in H^1_\pi(M).$$

Exercise 11.12. If M is orientable, show that this class coincides with the modular class $c(\bigwedge^{\text{top}} T^*M, \nabla) = \text{mod}(M, \pi)$.

This exercise allows us to define the **modular class** for any Poisson manifold (M, π) , orientable or not, as

$$\text{mod}(M, \pi) := c\left(\bigwedge^{\text{top}} T^*M, \nabla\right). \quad \img alt="fish icon" data-bbox="825 685 855 705"/>$$

11.2. Parallel transport along cotangent paths

Connections are useful for connecting and comparing fibers over different base points. This is done using parallel transport along paths. As one may expect, the generalization to contravariant connections requires the use of cotangent paths.

For this, fix a Poisson manifold (M, π) and a vector bundle $p : E \rightarrow M$ with a contravariant connection ∇ . Consider a cotangent path $a : [0, 1] \rightarrow T^*M$ and a path $c : [0, 1] \rightarrow E$ “above” a , i.e., such that

$$p(c(t)) = \gamma_a(t), \quad \forall t \in [0, 1].$$

One can find a time-dependent section $s_t \in \Gamma(E)$ extending c , i.e., such that

$$s_t(\gamma_a(t)) = c(t), \quad \forall t \in [0, 1].$$

This allows one to define

$$(11.3) \quad (D_a c)(t) = \nabla_{a(t)} s_t + \left. \frac{d}{dt} s_t \right|_{\gamma_a(t)}.$$

Exercise 11.13. Check that expression (11.3) is independent of the choice of time-dependent extension s_t . Would $D_a c$ still be well-defined if a was not a cotangent path?

HINT: No!

Definition 11.14. One calls $D_a c$ the **contravariant derivative** of c along the cotangent path a .

The local expression of the contravariant derivative is

$$(11.4) \quad D_a c(t) = \sum_{k=1}^r \left(\frac{d}{dt} c_k(t) + \sum_{\substack{1 \leq i \leq n \\ 1 \leq l \leq r}} \Gamma_k^{il}(\gamma_a(t)) a_i(t) c_l(t) \right) e^k,$$

where we use the Christoffel symbols (11.1), and we write

$$a(t) = \sum_{i=1}^n a_i(t) dx^i, \quad c(t) = \sum_{l=1}^r c_l(t) e^l.$$

This follows by using the time-dependent section $s_t(x) := c(t)$ in (11.3).

One verifies immediately that the contravariant derivative D satisfies the following:

(i) **Linearity:** If $c_1, c_2 : [0, 1] \rightarrow E$ are paths above a and $\lambda_1, \lambda_2 \in \mathbb{R}$, then

$$D_a(\lambda_1 c_1 + \lambda_2 c_2) = \lambda_1 D_a c_1 + \lambda_2 D_a c_2.$$

(ii) **Leibniz:** If $c : [0, 1] \rightarrow E$ is a path above a and $f \in C^\infty(M)$, then

$$D_a((f \circ \gamma_a) c) = (f \circ \gamma_a) D_a c + \left(\frac{d}{dt} f \circ \gamma_a \right) c.$$

These properties reveal an alternative description of the contravariant derivative:

Exercise 11.15. Let $\bar{\nabla} = a^* \nabla$ be the pullback connection along the cotangent path $a : [0, 1] \rightarrow T^*M$, as in Example 11.5. Show that

$$D_a c = \bar{\nabla} \frac{d}{dt} c,$$

where we identify curves $c : [0, 1] \rightarrow E$ above γ_a with sections $c \in \Gamma(\gamma_a^* E)$.

The contravariant derivative gives more geometric insight into the notion of curvature. For this, consider a cotangent map defined on the square:

$$\begin{aligned} \Phi &: T([0, 1] \times [0, 1]) \rightarrow T^*M, \\ \Phi(t, \varepsilon) &= \Phi_1(t, \varepsilon) dt + \Phi_2(t, \varepsilon) d\varepsilon, \end{aligned}$$

with base map $\gamma : [0, 1] \times [0, 1] \rightarrow M$. Consider now any smooth map $c : [0, 1] \times [0, 1] \rightarrow E$ above γ . Then, as explained in Section 10.4:

- For fixed a $\varepsilon = \varepsilon_0$, the map $t \mapsto \Phi_1(t, \varepsilon_0)$ is a cotangent path covering the path $t \mapsto \gamma(t, \varepsilon_0)$. Therefore we have the contravariant derivative of c in the t -direction, resulting in a new map above γ :

$$\begin{aligned} D_{\Phi_1}c &: [0, 1] \times [0, 1] \rightarrow E, \\ (D_{\Phi_1}c)(t, \varepsilon_0) &:= (D_{\Phi_1(\cdot, \varepsilon_0)}c(\cdot, \varepsilon_0))(t). \end{aligned}$$

- Similarly, by freezing t , we obtain the contravariant derivative of c in the ε -direction, which defines a new map above γ :

$$\begin{aligned} D_{\Phi_2}c &: [0, 1] \times [0, 1] \rightarrow E, \\ (D_{\Phi_2}c)(t_0, \varepsilon) &:= (D_{\Phi_2(t_0, \cdot)}c(t_0, \cdot))(\varepsilon). \end{aligned}$$

The curvature has the following interpretation:

Proposition 11.16. *Given a contravariant vector bundle (E, ∇) over a Poisson manifold (M, π) , one has*

$$R_{\nabla}(\Phi_1, \Phi_2)c = D_{\Phi_1}D_{\Phi_2}c - D_{\Phi_2}D_{\Phi_1}c,$$

for any cotangent map $\Phi : T([0, 1] \times [0, 1]) \rightarrow T^*M$, covering a base map $\gamma : [0, 1] \times [0, 1] \rightarrow M$, and any map $c : [0, 1] \times [0, 1] \rightarrow E$ above γ .

Proof. This result can be proven by pulling back the connection via the map Φ to a classical connection on γ^*E and then using that the curvatures are related via Φ — see Example 11.5. The statement is then reduced to the similar statement for classical connections, which can be found for example in [137]. We also give a self-contained proof.

Choose a (t, ε) -dependent section $s_{t,\varepsilon} \in \Gamma(E)$ extending $c(t, \varepsilon)$,

$$s_{t,\varepsilon}(\gamma(t, \varepsilon)) = c(t, \varepsilon),$$

and choose (t, ε) -dependent 1-forms $\alpha_{t,\varepsilon}, \beta_{t,\varepsilon} \in \Omega^1(M)$ extending Φ_1 and Φ_2 ,

$$\alpha_{t,\varepsilon}(\gamma(t, \varepsilon)) = \Phi_1(t, \varepsilon), \quad \beta_{t,\varepsilon}(\gamma(t, \varepsilon)) = \Phi_2(t, \varepsilon).$$

According to the definition of contravariant derivative (11.3), we have

$$D_{\Phi_1}c(t, \varepsilon) = \left(\nabla_{\alpha_{t,\varepsilon}}s_{t,\varepsilon} + \frac{d}{dt}s_{t,\varepsilon} \right) \Big|_{\gamma(t,\varepsilon)},$$

$$D_{\Phi_2}c(t, \varepsilon) = \left(\nabla_{\beta_{t,\varepsilon}}s_{t,\varepsilon} + \frac{d}{d\varepsilon}s_{t,\varepsilon} \right) \Big|_{\gamma(t,\varepsilon)}.$$

It follows that

$$D_{\Phi_1}D_{\Phi_2}c(t, \varepsilon) = \left(\nabla_{\alpha_{t,\varepsilon}}\nabla_{\beta_{t,\varepsilon}}s_{t,\varepsilon} + \frac{d}{dt}\nabla_{\beta_{t,\varepsilon}}s_{t,\varepsilon} + \nabla_{\alpha_{t,\varepsilon}}\frac{ds_{t,\varepsilon}}{d\varepsilon} + \frac{d^2s_{t,\varepsilon}}{dtd\varepsilon} \right) \Big|_{\gamma(t,\varepsilon)},$$

$$D_{\Phi_2}D_{\Phi_1}c(t, \varepsilon) = \left(\nabla_{\beta_{t,\varepsilon}}\nabla_{\alpha_{t,\varepsilon}}s_{t,\varepsilon} + \frac{d}{d\varepsilon}\nabla_{\alpha_{t,\varepsilon}}s_{t,\varepsilon} + \nabla_{\beta_{t,\varepsilon}}\frac{ds_{t,\varepsilon}}{dt} + \frac{d^2s_{t,\varepsilon}}{d\varepsilon dt} \right) \Big|_{\gamma(t,\varepsilon)}.$$

Taking the difference of these two equations, we obtain

$$D_{\Phi_1}D_{\Phi_2}c(t, \varepsilon) - D_{\Phi_2}D_{\Phi_1}c(t, \varepsilon) = \left(\nabla_{\alpha_{t,\varepsilon}}\nabla_{\beta_{t,\varepsilon}}s_{t,\varepsilon} - \nabla_{\beta_{t,\varepsilon}}\nabla_{\alpha_{t,\varepsilon}}s_{t,\varepsilon} + \nabla_{\frac{d}{dt}\beta_{t,\varepsilon} - \frac{d}{d\varepsilon}\alpha_{t,\varepsilon}}s_{t,\varepsilon} \right) \Big|_{\gamma(t,\varepsilon)}.$$

Using property (iii) from Proposition 10.17, we obtain the result

$$D_{\Phi_1}D_{\Phi_2}c(t, \varepsilon) - D_{\Phi_2}D_{\Phi_1}c(t, \varepsilon) = (R_{\nabla}(\alpha_{t,\varepsilon}, \beta_{t,\varepsilon})s_{t,\varepsilon}) \circ \gamma(t, \varepsilon) = R_{\nabla}(\Phi_1, \Phi_2)c(t, \varepsilon). \quad \square$$

Let us now turn to parallelism and parallel transport.

Definition 11.17. Let (E, ∇) be a contravariant vector bundle over (M, π) . We say that $c : [0, 1] \rightarrow E$ is a **parallel curve** along a cotangent path $a : [0, 1] \rightarrow T^*M$ if c lies above a and

$$D_a c = 0.$$

Proposition 11.18. Let (E, ∇) be a contravariant vector bundle over (M, π) . Given a cotangent path $a : [0, 1] \rightarrow T^*M$ and a point $u \in E_{\gamma_a(0)}$ there is a unique parallel curve $c_u : [0, 1] \rightarrow E$ along a , starting at u . Moreover, the end point $c_u(1)$ of this curve depends linearly on u .

Proof. This result can be proven by pulling back ∇ via a to a classical connection on $\gamma_a^*E \rightarrow [0, 1]$, as in Exercise 11.15. This reduces the result to the existence of parallel transport of a classical connection over the interval. Here we give a self-contained argument.

Assume first that the base path γ_a belongs to the domain of a coordinate chart (U, x^i) where E admits a basis of sections $\{e_i\}$. By (11.4), a parallel curve $c(t)$ along $a(t)$ with initial condition u is a solution of the system of

ODEs

$$\begin{cases} \frac{d}{dt}c_k(t) = -\sum_{\substack{1 \leq i \leq n \\ 1 \leq l \leq r}} \Gamma_k^{il}(\gamma_a(t)) a_i(t) c_l(t) & (k = 1, \dots, r), \\ c(0) = u. \end{cases}$$

Since $a(t)$ and $\gamma_a(t)$ are given, this is a linear system of ODEs with time-dependent coefficients. So, for any $u \in E_{\gamma_a(0)}$ a unique solution exists, which is defined as long as the coefficients are defined, i.e., on $[0, 1]$, and the solution depends linearly on u .

In general, consider a partition $0 = t_0 < t_1$ such that each segment $\gamma_a([t_p, t_{p+1}])$ is covered by a chart as above. By the first part, we find inductively parallel paths $c_p : [t_p, t_{p+1}] \rightarrow E$ over $a|_{[t_p, t_{p+1}]}$ satisfying the initial conditions

$$c_0(0) = u \quad \text{and} \quad c_p(t_p) = c_{p-1}(t_p) \quad (p \geq 1).$$

The path $c : [0, 1] \rightarrow E$ obtained by gluing the paths c_p is smooth at the points t_1, \dots, t_{q-1} . This holds by local uniqueness around these points. \square

In conclusion, any cotangent path $a : [0, 1] \rightarrow T^*M$ yields a linear map

$$\tau_a : E_{\gamma_a(0)} \rightarrow E_{\gamma_a(1)}, \quad u \mapsto c_u(1).$$

The map τ_a is called the **parallel transport** of the contravariant connection ∇ along the cotangent path a . The uniqueness of parallel paths shows that τ_a is injective, and so it is a linear isomorphism between the fibers.

Example 11.19. Consider a linear Poisson manifold $(\mathfrak{g}^*, \pi_{\mathfrak{g}})$. Let $\rho : \mathfrak{g} \rightarrow \mathfrak{gl}(W)$ be a representation of \mathfrak{g} . We view $\mathfrak{g} \subset \Omega^1(\mathfrak{g}^*)$ by interpreting elements in \mathfrak{g} as constant 1-forms. Define a contravariant connection on the trivial bundle $\mathfrak{g}^* \times W \rightarrow \mathfrak{g}^*$ by requiring that on constant sections it satisfies

$$\nabla_v w := \rho(v)w.$$

The fact that ρ is a representation implies flatness of ∇ .

Since the origin is a zero of $\pi_{\mathfrak{g}}$, any element $v \in T_0^*\mathfrak{g}^* \simeq \mathfrak{g}$ defines the constant cotangent path $a_v(t) = v$ and parallel transport gives a map

$$\tau_{a_v} : W \rightarrow W.$$

Exercise 11.20. Show that $\tau_{a_v} = \exp(\rho(v))$.



11.3. Flat contravariant connections

Proposition 11.21. *Let (E, ∇) be a contravariant vector bundle over (M, π) . If ∇ is flat, then any two cotangent paths $a_0, a_1 : [0, 1] \rightarrow T^*M$ that are cotangent path-homotopic induce the same parallel transport: $\tau_{a_0} = \tau_{a_1}$.*

Proof. Let $\Phi : T([0, 1] \times [0, 1]) \rightarrow T^*M$ be a cotangent path-homotopy between a_0 and a_1 covering $\gamma : [0, 1] \times [0, 1] \rightarrow M$, with components

$$\Phi(t, \varepsilon) = \Phi_1(t, \varepsilon)dt + \Phi_2(t, \varepsilon)d\varepsilon.$$

Then $\{\Phi_1(\cdot, \varepsilon)\}_{\varepsilon \in [0, 1]}$ is a family of cotangent paths joining a_0 to a_1 , all starting at $\gamma(0, 0)$. Fix $u \in E_{\gamma(0, 0)}$, and let $\tau_{\Phi_1}^{t, 0}(u)$ denote the parallel transport of u along $\Phi_1(\cdot, \varepsilon)|_{[0, t]}$. This yields a map covering γ , which we denote

$$c : [0, 1] \times [0, 1] \rightarrow E, \quad c(t, \varepsilon) = \tau_{\Phi_1}^{t, 0}(u) \in E_{\gamma(t, \varepsilon)},$$

and which satisfies $D_{\Phi_1}c = 0$. We claim that c is parallel also along the cotangent paths $\{\Phi_2(t, \cdot)\}_{t \in [0, 1]}$. At $t = 0$, since Φ is a path-homotopy, we have that $\Phi_2(0, \varepsilon) = \partial\Phi(0, \varepsilon) = 0$. Since $c(0, \varepsilon) = u$ is constant, by (11.3) we obtain

$$D_{\Phi_2(0, \cdot)}c = \frac{d}{d\varepsilon}c(0, \cdot) = 0.$$

Next, using Proposition 11.16 and that ∇ is flat, we have

$$D_{\Phi_1}D_{\Phi_2}c = R_{\nabla}(\Phi_1, \Phi_2)c + D_{\Phi_2}D_{\Phi_1}c = 0.$$

So $D_{\Phi_2}c$ is parallel along $\Phi_1(\cdot, \varepsilon)$. Uniqueness of parallel paths yields $D_{\Phi_2}c = 0$. At $t = 1$, we also have $\Phi_2(1, \varepsilon) = \partial\Phi(1, \varepsilon) = 0$. So, again by (11.3),

$$\frac{d}{d\varepsilon}c(1, \cdot) = D_{\Phi_2(1, \cdot)}c = 0.$$

This shows that $c(1, \varepsilon) = \tau_{\Phi_1(1, \varepsilon)}(u)$ is constant, proving the result. \square

Note that parallel transport is compatible with concatenation of cotangent paths. Therefore, the proposition implies:

Corollary 11.22. *Let (E, ∇) be a flat contravariant vector bundle over (M, π) . For any base point $x \in M$, parallel transport defines a representation of the Poisson homotopy group on E_x*

$$\Pi(M, \pi, x) \rightarrow \text{GL}(E_x), \quad [a] \mapsto \tau_a.$$

For line bundles, this map is described explicitly in the following proposition, which relates parallel transport to the characteristic class.

Proposition 11.23. *Let (L, ∇) be a flat contravariant line bundle over a Poisson manifold (M, π) . Assume there is a nowhere vanishing section $\mu \in \Gamma(L)$, and let $c_\mu \in \mathfrak{X}(M)$ be the corresponding Poisson vector field (11.2). The parallel transport along any cotangent path $a : [0, 1] \rightarrow T^*M$ is given by*

$$\tau_a(\mu_{\gamma(0)}) = \exp\left(-\int_a c_\mu\right) \cdot \mu_{\gamma(1)}.$$

In particular, if γ_a is a loop based at $x \in M$, then

$$(11.5) \quad \tau_a = \exp \left(- \int_a c(L, \nabla) \right).$$

Proof. A path $c : [0, 1] \rightarrow L$ covering γ_a has the form $c(t) = g(t)\mu_{\gamma_a(t)}$, for some smooth map $g : [0, 1] \rightarrow \mathbb{R}$. Using (11.3), we see that c is parallel iff

$$\frac{d}{dt}g(t) = -c_\mu(a(t))g(t).$$

The solution to this ODE is

$$g(t) = \exp \left(- \int_0^t c_\mu(a(s)) ds \right) g(0),$$

and this implies the result. □

Remark 11.24. Up to isomorphism, a line bundle $L \rightarrow M$ is uniquely determined by its *first Stiefel-Whitney class* $w_1(L) \in H^1(M, \mathbb{Z}_2)$, which can be defined as follows. If $[\gamma] \in H_1(M, \mathbb{Z})$ is represented by a loop γ based at x , then the value $\langle w_1(L), [\gamma] \rangle \in \mathbb{Z}_2$ is either 0 or 1 depending on:

- whether the line bundle $\gamma^*(L) \rightarrow \mathbb{S}^1$ is trivial or not.

This condition can be expressed geometrically in several, equivalent ways. For example, it is equivalent to the following:

- parallel transport along γ w.r.t. any classical connection is orientation preserving or reversing, or
- $[\gamma] \in \pi_1(M, x)$ does or does not induce the trivial deck transformation on the 2 : 1 covering space $\mathbb{P}(L) \rightarrow M$.

Exercise 11.25. If L is not orientable, show that formula (11.5) giving the parallel transport along loops needs to be corrected by the factor

$$(-1)^{\langle w_1(L), [\gamma_a] \rangle},$$

where $[\gamma_a] \in H_1(M, \mathbb{Z})$ is the homology class of the base path γ_a .

We saw in Example 11.6 that a regular Poisson manifold (M, π) carries a canonical flat contravariant connection, namely the Bott connection on the conormal bundle $\nu^*(\mathcal{F}_\pi) := (T\mathcal{F}_\pi)^\circ$. We look at parallel transport for this connection.

Definition 11.26. Given a cotangent path $a : [0, 1] \rightarrow T^*M$ on a Poisson manifold (M, π) lying in a symplectic leaf S , the parallel transport map for the contravariant Bott connection

$$\text{Hol}_a := \tau_a : \nu_{\gamma_a(0)}^*(S) \rightarrow \nu_{\gamma_a(1)}^*(S)$$

is called the **linear Poisson holonomy** of a .

Since the Bott connection is flat, the linear Poisson holonomy Hol_a depends only on the cotangent path-homotopy class $[a]$. In fact, more is true:

Exercise 11.27. Show that Hol_a depends only on the path-homotopy class of the base path γ_a .

(HINT: Show that $\nu^*(S) \rightarrow S$ carries an ordinary flat connection $\bar{\nabla}$, such that Hol_a coincides with the parallel transport τ_{γ_a} of $\bar{\nabla}$ along γ_a .)

For a regular Poisson manifold (M, π) , we also have a canonical isomorphism of line bundles

$$(11.6) \quad i_{\pi^k} : \bigwedge^n T^*M \xrightarrow{\sim} \bigwedge^q \nu^*(\mathcal{F}_\pi), \quad \mu \mapsto \mu^\perp := i_{\pi^k} \mu$$

where $2k = \text{rank}(\pi)$, $n = \dim(M)$, $q := n - 2k = \text{codim}(\mathcal{F}_\pi)$, and so π^k is a nowhere zero section of the line bundle $\bigwedge^{2k} T\mathcal{F}_\pi$. For a volume form $\mu \in \Omega^n(M)$ the form $\mu^\perp \in \Gamma(\bigwedge^q \nu^*(\mathcal{F}_\pi))$ can be thought of as a *transverse volume form* to the foliation \mathcal{F}_π , hence the notation.

As an application of Proposition 11.23, we have the following:

Theorem 11.28 (Ginzburg and Golubev [78]). *Let (M, π) be a regular Poisson manifold with volume form μ and corresponding modular vector field X_μ . For any cotangent path $a : [0, 1] \rightarrow T^*M$, we have that*

$$\det(\text{Hol}_a) = \exp \left(- \int_a X_\mu \right),$$

where the determinant is relative to the volume forms $\mu^\perp_{\gamma_a(0)}$ on $\nu^*_{\gamma_a(0)}(\mathcal{F}_\pi)$ and $\mu^\perp_{\gamma_a(1)}$ on $\nu^*_{\gamma_a(1)}(\mathcal{F}_\pi)$. In particular, if γ_a is a loop,

$$\det(\text{Hol}_a) = \exp \left(- \int_a \text{mod}(M, \pi) \right).$$

Proof. The Bott connection induces a contravariant, flat connection on $\bigwedge^q \nu^*(\mathcal{F}_\pi)$ via the derivation rule

$$(11.7) \quad \nabla_\alpha(s_1 \wedge \cdots \wedge s_q) = \nabla_\alpha s_1 \wedge \cdots \wedge s_q + \cdots + s_1 \wedge \cdots \wedge \nabla_\alpha s_q.$$

We leave it to the reader to check that the parallel transport along a cotangent path $a : [0, 1] \rightarrow T^*M$ in $\nu^*(\mathcal{F}_\pi)$, i.e., the linear Poisson holonomy Hol_a , and the parallel transport τ_a in $\bigwedge^q \nu^*(\mathcal{F}_\pi)$ are related by

$$\tau_a = \bigwedge^q \text{Hol}_a : \bigwedge^q \nu^*_{\gamma_a(0)}(\mathcal{F}_\pi) \rightarrow \bigwedge^q \nu^*_{\gamma_a(1)}(\mathcal{F}_\pi).$$

Equivalently, if μ^\perp is a section of $\bigwedge^q \nu^*(\mathcal{F}_\pi)$, we have

$$(11.8) \quad \tau_a(\mu^\perp_{\gamma_a(0)}) = \det(\text{Hol}_a) \cdot \mu^\perp_{\gamma_a(1)}.$$

Fix a volume form $\mu \in \Omega^n(M)$. As explained in Example 11.11, the modular class $\text{mod}(M, \pi)$ coincides with the characteristic class $c(\bigwedge^n T^*M, \nabla)$,

and the representatives associated to μ coincide: $X_\mu = c_\mu$. Applying Proposition 11.23, one obtains the following formula for the parallel transport of the connection on $\bigwedge^n T^*M$:

$$(11.9) \quad \tilde{\tau}_a(\mu_{\gamma_a(0)}) = \exp\left(-\int_a X_\mu\right) \cdot \mu_{\gamma_a(1)}.$$

We now claim that the isomorphism (11.6) intertwines the contravariant connections on $\bigwedge^n T^*M$ and $\bigwedge^q \nu^*(\mathcal{F}_\pi)$:

$$i_{\pi^k} \nabla_\alpha \xi = \nabla_\alpha i_{\pi^k} \xi, \quad \forall \alpha \in \Omega^1(M), \xi \in \Omega^n(M).$$

In view of formulas (11.8) and (11.9) the statement will follow. To prove the claim, note that the definition of the Bott connection gives

$$\nabla_{df} s = [df, s]_\pi = \mathcal{L}_{X_f} s, \quad \forall f \in C^\infty(M), s \in \Gamma(\nu^*(\mathcal{F}_\pi)).$$

By the defining derivation rule (11.7), the connection on $\bigwedge^q \nu^*(\mathcal{F}_\pi)$ also satisfies $\nabla_{df} = \mathcal{L}_{X_f}$. By definition — see Example 11.7 — the same also holds for the connection on $\bigwedge^n T^*M$. Hence, since $\mathcal{L}_{X_f} \pi^k = 0$, we obtain that

$$i_{\pi^k} \nabla_{df} \xi = i_{\pi^k} \mathcal{L}_{X_f} \xi = \mathcal{L}_{X_f} i_{\pi^k} \xi = \nabla_{df} i_{\pi^k} \xi.$$

The claim follows by $C^\infty(M)$ -linearity, and this concludes the proof. \square

Remark 11.29 (Linear Poisson holonomy for general leaves). How can one make sense of the contravariant Bott connection and linear holonomy for a nonregular Poisson manifold? In this case, the conormal bundle is not a smooth vector bundle. However, we still have the conormal bundle over each leaf and it still carries a canonical Bott connection. To define it we need the more general notion of an A -connection for a Lie algebroid A — see Problem 11.8.

Let (S, ω_S) be a symplectic leaf of (M, π) . The restriction $T_S^*M \rightarrow S$ is a Lie algebroid for which the inclusion $T_S^*M \hookrightarrow T^*M$ is a Lie algebroid map — see Remark 9.43. Hence, the Lie bracket satisfies the relation

$$[\alpha|_S, \beta|_S]_{T_S^*M} := [\alpha, \beta]_\pi|_S, \quad \forall \alpha, \beta \in \Omega^1(M).$$

The conormal bundle $\nu^*(S)$ carries a Bott T_S^*M -connection

$$\Gamma(T_S^*M) \times \Gamma(\nu^*(S)) \rightarrow \Gamma(\nu^*(S)), \quad \nabla_\alpha s := [\alpha, s]_{T_S^*M}.$$

Next, one can define the parallel transport along a cotangent path $a : [0, 1] \rightarrow T^*M$ with base path γ_a contained in S :

$$\text{Hol}_a := \tau_a : \nu_{\gamma_a(0)}^*(S) \rightarrow \nu_{\gamma_a(1)}^*(S).$$

This defines the linear Poisson holonomy map for a general leaf S . The Bott T_S^*M -connection is still flat, and then Hol_a depends only the cotangent

path-homotopy class of a . Therefore:

Corollary 11.30. *For each point in a Poisson manifold, linear Poisson holonomy gives a canonical representation on the conormal space to the leaf:*

$$\text{Hol} : \Pi(M, \pi, x) \rightarrow \text{GL}(\nu_x^*(S)).$$

However, compared to the case of regular leaves, Hol_a will depend on more than just the path-homotopy class of the base map γ_a . This already becomes clear for linear Poisson structures:

Exercise 11.31. For a linear Poisson structure $(\mathfrak{g}^*, \pi_{\mathfrak{g}})$ and the leaf $S = \{0\}$, show that the representation resulting from the corollary is the adjoint representation of the 1-connected Lie group with Lie algebra \mathfrak{g} . (HINT: See Examples 10.30 and 11.19.)

Theorem 11.28 also holds for nonregular leaves. Note that for a volume form μ , the formula $\mu_S^\perp := i_{\pi^*} \mu|_S$ still defines a nonzero section of $\bigwedge^q \nu^*(S)$.

11.4. Geodesics for contravariant connections

Contravariant connections on the cotangent bundle itself, i.e., on $E = T^*M$, play a special and important role. For these we can define torsion:

Definition 11.32. A **contravariant connection on a Poisson manifold** (M, π) is a contravariant connection ∇ on the bundle T^*M . The **torsion** of ∇ is the T^*M -valued bivector field

$$T_\nabla \in \mathfrak{X}^2(M; T^*M), \quad T_\nabla(\alpha, \beta) := \nabla_\alpha \beta - \nabla_\beta \alpha - [\alpha, \beta]_\pi.$$

Exercise 11.33. Check that T_∇ is indeed $C^\infty(M)$ -bilinear, so that it defines a section of $\bigwedge^2 TM \otimes T^*M$.

Example 11.34. Consider a linear Poisson manifold $(\mathfrak{g}^*, \pi_{\mathfrak{g}})$. We view elements of \mathfrak{g} as constant 1-form in $\Omega^1(\mathfrak{g}^*)$. Define a contravariant connection by defining it on constant 1-forms as

$$\nabla_v w := \frac{1}{2}[v, w]_{\mathfrak{g}},$$

and then extending it by imposing the properties of a connection. Using skew-symmetry and the Jacobi identity, one sees that

$$T_\nabla = 0, \quad R_\nabla(v, w)z = \frac{1}{4}[v, [w, z]_{\mathfrak{g}}]_{\mathfrak{g}}.$$

So this connection is torsion-free and, in general, nonflat.



Similar to the interpretation of curvature in terms of contravariant derivatives from Proposition 11.16, torsion has the following interpretation:

Proposition 11.35. *Let (M, π) be a Poisson manifold and consider a bundle map $\Phi = \Phi_1 dt + \Phi_2 d\varepsilon : T([0, 1] \times [0, 1]) \rightarrow T^*M$ with base map $\gamma : [0, 1] \times [0, 1] \rightarrow M$. Assume that Φ is compatible with its base map*

$$\pi^\sharp \circ \Phi = d\gamma.$$

Then Φ is a cotangent map if and only if it satisfies

$$T_\nabla(\Phi_1, \Phi_2) = D_{\Phi_1}\Phi_2 - D_{\Phi_2}\Phi_1,$$

where ∇ is any contravariant connection.

We leave the proof as an exercise. As in the proof of Proposition 11.16 you will have to apply the crucial Proposition 10.17.

A contravariant connection ∇ on T^*M induces a dual contravariant connection $\bar{\nabla}$ on TM by requiring the following derivation rule:

$$\mathcal{L}_{\pi^\sharp(\alpha)}\langle X, \beta \rangle = \langle X, \nabla_\alpha\beta \rangle + \langle \nabla_\alpha X, \beta \rangle,$$

for all $\alpha, \beta \in \Omega^1(M)$ and $X \in \mathfrak{X}(M)$. Similarly, ∇ induces contravariant connections on all associated tensor bundles such as $\otimes^k TM, \otimes^l T^*M, S^k TM, \wedge^l T^*M$, etc., defined via similar derivation rules. For example, the connection on $\wedge^k TM$ is determined by

$$\nabla_\alpha(X_1 \wedge \cdots \wedge X_k) = (\nabla_\alpha X_1 \wedge \cdots \wedge X_k) + \cdots + (X_1 \wedge \cdots \wedge \nabla_\alpha X_k).$$

In particular, given a contravariant connection ∇ on (M, π) we can write the $(3, 0)$ -tensor $\nabla\pi$. We leave it as an exercise to show that a Poisson manifold (M, π) always admits a contravariant connection ∇ for which

$$\nabla\pi = 0.$$

In contrast, note that (M, π) admits an ordinary covariant connection $\bar{\nabla}$ with $\bar{\nabla}\pi = 0$ if and only if π has constant rank: in this case, parallel transport along any path would preserve the bivector field.

Definition 11.36. Let ∇ be a contravariant connection on (M, π) . A **geodesic** for ∇ is a cotangent path $a : I \rightarrow T^*M$ which is parallel along itself:

$$D_a a = 0.$$

In general, geodesics exist only for a short time interval, even if M is compact. To see this, we write the geodesics equations of a contravariant

connection ∇ on a Poisson manifold (M, π) in local coordinates (U, x^i) . The connection determines Christoffel symbols $\Gamma_k^{ij} \in C^\infty(U)$, via

$$\nabla_{dx^i} dx^j = \sum_{k=1}^n \Gamma_k^{ij} dx^k \quad (1 \leq i, j \leq n).$$

Using the local equations of the covariant derivative (11.4), one finds that $a(t) = \sum_i a_i(t) dx^i$ with base path $\gamma_a(t) = (\gamma_a^i(t))$ is a geodesic if and only if

$$\begin{cases} \frac{da_k}{dt}(t) = -\sum_{1 \leq i, j \leq n} \Gamma_k^{ij}(\gamma_a(t)) a_i(t) a_j(t), \\ \frac{d\gamma_a^k}{dt}(t) = \sum_{1 \leq i \leq n} \pi^{ik}(\gamma_a(t)) a_i(t) \end{cases} \quad (k = 1, \dots, n).$$

In other words, the geodesics are the integral curves of the vector field $X \in \mathfrak{X}(T^*M)$ given in local coordinates (x^i, p_i) by

$$(11.10) \quad X = \sum_{1 \leq i, k \leq n} \pi^{ik}(x) p_i \frac{\partial}{\partial x^k} - \sum_{1 \leq i, j, k \leq n} \Gamma_k^{ij}(x) p_i p_j \frac{\partial}{\partial p_k}.$$

We call the vector field X the **geodesic spray** of the connection ∇ , and we call its flow the **geodesic flow** of the connection.

Exercise 11.37. Show that expression (11.10) leads to a well-defined vector field on T^*M , independent of the choice of coordinates.

HINT: There is a proof without local coordinate computations.

Exercise 11.38. Give an example of a compact Poisson manifold (M, π) for which geodesics are not defined for all time. What if (M, π) has compact symplectic leaves?

(HINT: The vector field $p^2 \frac{\partial}{\partial p}$ on \mathbb{R} is not complete.)

Two different connections can have the same geodesics, i.e., the same geodesic spray. Moreover, expression (11.10) for the geodesic spray shows that its local coordinate expression depends only on the *symmetric part* of the Christoffel symbols, i.e., on $\frac{1}{2}(\Gamma_k^{ij} + \Gamma_k^{ji})$. The coordinate independent version of this statement is the following:

Proposition 11.39. *For a contravariant connection ∇ on (M, π) , there is a unique torsion-free contravariant connection $\tilde{\nabla}$ with the same geodesics.*

Proof. Define the torsion-free connection $\tilde{\nabla}$ by setting

$$\tilde{\nabla}_\alpha \beta := \nabla_\alpha \beta - \frac{1}{2} T_\nabla(\alpha, \beta).$$

If we fix local coordinates (x^i) for M , one finds that the Christoffel symbols of the two connections are related by

$$\tilde{\Gamma}_k^{ij} = \frac{1}{2} \left(\Gamma_k^{ij} + \Gamma_k^{ji} + \frac{\partial \pi^{ij}}{\partial x^k} \right).$$

It follows from expression (11.10) that the two connections have the same geodesic flows, and hence the same geodesics.

For the uniqueness of the connection, we note that the symmetric part of the Christoffel symbols $\Gamma_k^{ij} + \Gamma_k^{ji}$ is determined by the geodesic spray and that being torsion-free determines the antisymmetric part of the Christoffel symbols $\Gamma_k^{ij} - \Gamma_k^{ji} = \frac{\partial \pi^{ij}}{\partial x^k}$. □

It follows from the previous proposition that a torsion-free contravariant connection ∇ on (M, π) is completely determined by its geodesic spray. Moreover, we can even characterize the vector fields on T^*M that are geodesic sprays of torsion-free connections:

Proposition 11.40. *Let (M, π) be a Poisson manifold. The geodesic spray $X \in \mathfrak{X}(T^*M)$ of any contravariant connection ∇ on (M, π) satisfies the following:*

- (i) $d_\xi \text{pr}(X_\xi) = \pi^\sharp(\xi)$, for all $\xi \in T^*M$,
- (ii) $(m_t)_*X = \frac{1}{t}X$, for all $t > 0$,

where $\text{pr} : T^*M \rightarrow M$ denotes the projection and $m_t : T^*M \rightarrow T^*M$ is the scalar multiplication by $t \in \mathbb{R}$.

Conversely, any vector field $X \in \mathfrak{X}(T^*M)$ satisfying (i) and (ii) is the spray of a unique torsion-free contravariant connection ∇ on (M, π) .

Proof. Using the local expression (11.10) for the geodesic spray, one checks easily that it satisfies properties (i) and (ii).

For the converse, let $X \in \mathfrak{X}(T^*M)$ be a vector field, and fix local coordinates (U, x^i) for M , inducing local coordinates $(T^*U, (x^i, p_i))$ for T^*M . In these local coordinates, we can write

$$X = \sum_k u^k(x, p) \frac{\partial}{\partial x^k} - \sum_k v_k(x, p) \frac{\partial}{\partial p_k}$$

for smooth function $u^k, v_k : T^*U \rightarrow \mathbb{R}$.

If X satisfies condition (i), then the coefficients u^k are given by

$$u^k(x, p) = \sum_i \pi^{ik}(x) p_i,$$

where the $\pi^{ij}(x)$ are the structure functions of π relative to the coordinates (x^i) . If X satisfies condition (ii), then the functions v_k are quadratic in (p_i) :

$$v_k(x, p) = \sum_{ij} v_k^{ij}(x) p_i p_j.$$

Let ∇ be the contravariant connection on U with Christoffel symbols Γ_k^{ij} satisfying the relations

$$\begin{aligned}\Gamma_k^{ij}(x) - \Gamma_k^{ji}(x) &= \frac{\partial \pi^{ij}}{\partial x^k}(x), \\ \Gamma_k^{ij}(x) + \Gamma_k^{ji}(x) &= v_k^{ij}(x) + v_k^{ji}(x).\end{aligned}$$

The first equation guarantees that ∇ is torsion-free, while the second equation guarantees that its geodesic spray is X . This shows that the desired torsion-free connection exists in any local coordinate system.

By Proposition 11.39, two torsion-free contravariant connections with the same geodesics coincide. Therefore, these local connections agree on overlaps and hence define a torsion-free connection on M . \square

Exercise 11.41. Show that the properties of a spray X from Proposition 11.40 are equivalent to the following properties of the flow ϕ_X^t of X :

- (i) \Leftrightarrow the flow lines $t \mapsto \phi_X^t(\xi)$ are cotangent paths.
- (ii) \Leftrightarrow the commutation relation

$$(11.11) \quad \phi_X^t \circ m_s = m_s \circ \phi_X^{st} \quad (t, s \in \mathbb{R}).$$

11.5. Existence of symplectic realizations

We now prove that every Poisson manifold (M, π) admits a symplectic realization. We use a contravariant connection on (M, π) to give a global version of the local construction discussed in Section 6.5.

Given a Poisson structure π on \mathbb{R}^n , Theorem 6.36 produces a symplectic realization with projection $\text{pr} : T^*\mathbb{R}^n \rightarrow \mathbb{R}^n$ restricted to an open neighborhood $U \subset T^*\mathbb{R}^n = \mathbb{R}^n \times (\mathbb{R}^n)^*$ of the zero section and symplectic form

$$\omega = \int_0^1 (\phi^t)^* \omega_{\text{can}} dt \in \Omega^2(U).$$

Here $\phi^t : \mathbb{R}^n \times (\mathbb{R}^n)^* \rightarrow \mathbb{R}^n \times (\mathbb{R}^n)^*$ is the map

$$(11.12) \quad \phi^t(x, p) = (\phi_{X_{f_p}}^t(x), p),$$

and X_{f_p} is the Hamiltonian vector field of the function $f_p(x) := \langle x, p \rangle$. This map is the flow of a vector field on $T^*\mathbb{R}^n$ and satisfies the properties of a geodesic flow given in Exercise 11.41.

Exercise 11.42. Check that the map (11.12) is the geodesic flow of the following:

- (a) the flat connection defined by

$$\nabla_{dx^i} dx^j = 0,$$

(b) the torsion-free contravariant connection on (\mathbb{R}^n, π) defined by

$$\nabla_{dx^i} dx^j = \frac{1}{2} \sum_{k=1}^n \frac{\partial \pi^{ij}}{\partial x^k} dx^k.$$

This suggests the following generalization of Theorem 6.36:

Theorem 11.43 (Crainic and Mărcuț [48]). *Let X be the geodesic spray of a contravariant connection on (M, π) . There is an open neighborhood $U \subset T^*M$ of the zero section on which the 2-form*

$$\omega := \int_0^1 (\phi_X^t)^* \omega_{\text{can}} dt$$

is symplectic and $\mu = \text{pr}|_U : (U, \omega) \rightarrow (M, \pi)$ is a symplectic realization.

The rest of this section is devoted to the proof of this result. We identify the zero section of T^*M with M . Since a geodesic spray X vanishes along M — see the local expression (11.10) — we can choose a small enough open neighborhood $U \subset T^*M$ of M where the geodesic flow $\phi_X^t : U \rightarrow T^*M$ is defined for all $t \in [0, 1]$. Thus, ω is defined on such a neighborhood U .

Let us look now at what happens with ω along M .

Lemma 11.44. *For the canonical decomposition*

$$(11.13) \quad T_M(T^*M) = TM \oplus T^*M,$$

we have that

$$\omega_{0_x}((u, \xi), (v, \eta)) = \eta(u) - \xi(v) + \pi(\xi, \eta),$$

for all $(u, \xi), (v, \eta) \in T_x M \oplus T_x^ M$.*

Proof. Under the identification (11.13), we have that the scalar multiplication and the flow satisfy

$$\frac{d}{ds} m_s(\xi) \Big|_{s=0} = (0, \xi), \quad d\phi_X^t(u, 0) = (u, 0),$$

where we used that $\phi_X^t|_M = \text{Id}_M$. Thus, by (11.11), we find that

$$\begin{aligned} d\phi_X^t(0, \xi) &= \frac{d}{ds} \phi_X^t \circ m_s(\xi) \Big|_{s=0} \\ &= \frac{d}{ds} m_s \circ \phi_X^{st}(\xi) \Big|_{s=0} \\ &= \frac{d}{ds} m_s(\xi) \Big|_{s=0} + d_\xi \text{pr}(tX_\xi) = (t\pi^\sharp(\xi), \xi). \end{aligned}$$

This shows that the differential of the flow along M is given by

$$d\phi_X^t : T_M(T^*M) \rightarrow T_M(T^*M), \quad (u, \xi) = (u + t\pi^\sharp(\xi), \xi).$$

Note that for $(u, \xi), (v, \eta) \in T_{0_x}(T^*M)$, we have that

$$\omega_{\text{can}}((u, \xi), (v, \eta)) = \eta(u) - \xi(v);$$

therefore, using the above formula for the differential of ϕ_X^t , we obtain that

$$\begin{aligned} (\phi_X^t)^* \omega_{\text{can}}((u, \xi), (v, \eta)) &= \omega_{\text{can}}((u + t\pi^\sharp(\xi), \xi), (v + t\pi^\sharp(\eta), \eta)) \\ &= \eta(u) - \xi(v) + 2t\pi(\xi, \eta). \end{aligned}$$

Integrating for $t \in [0, 1]$, we obtain the formula for ω . □

Using also the dual identification $T_M^*(T^*M) = T^*M \oplus TM$, the formula from the lemma is equivalent to

$$\omega^\flat : TM \oplus T^*M \rightarrow T^*M \oplus TM, \quad (u, \xi) \mapsto (-\xi, u + \pi^\sharp(\xi)).$$

This implies that ω is invertible along the zero section, with inverse

$$(11.14) \quad (\omega^{-1})^\sharp : T^*M \oplus TM \rightarrow TM \oplus T^*M, \quad (\eta, v) \mapsto (v + \pi^\sharp(\eta), -\eta).$$

This immediately implies that at points of the zero section the differential of the projection $\mu = \text{pr} : T^*M \rightarrow M$ fits into a commutative diagram:

$$\begin{array}{ccc} T_{0_x}^* T^*M & \xrightarrow{(\omega_{0_x}^{-1})^\sharp} & T_{0_x} T^*M \\ (\text{d}\mu)^* \uparrow & & \downarrow \text{d}\mu \\ T_x^*M & \xrightarrow{\pi_x^\sharp} & T_x M \end{array}$$

Since ω is nondegenerate along M , by shrinking U , we may assume that ω is a symplectic structure on U . By shrinking U even more, we may assume that the fibers of $\mu := p|_U : U \rightarrow M$ are connected. The strategy is to apply Libermann’s Theorem to obtain a Poisson structure on M for which μ is a symplectic realization. The previous diagram forces the resulting Poisson structure on the base to coincide with π , and the proof will be complete.

In order to apply Liberman’s Theorem to μ , all we need to show is that

$$\text{Ker}(\text{d}\mu)^{\perp\omega} \subset TU$$

is an involutive distribution. Involutivity will follow by showing that

$$(11.15) \quad \text{Ker}(\text{d}\mu)^{\perp\omega} = \text{Ker}(\text{d}\tau), \quad \text{where } \tau = \mu \circ \phi_X^1 : U \rightarrow M.$$

In order to prove this equality, we will use some Dirac geometry. Let L_π be the Dirac structure associated to π , and consider the pullback Dirac

structure $\mu^!L_\pi$ on T^*M :

$$\mu^!L_\pi = \{v + \mu^*\xi \in \mathbb{T}(T^*M) : d\mu(v) = \pi^\sharp(\xi)\}.$$

Let $\theta_L \in \Omega^1(T^*M)$ denote the Liouville 1-form; i.e., $\theta_{L,\xi} = \mu^*(\xi)$. Note that the first spray condition from Proposition 11.40 is equivalent to

$$s := X + \theta_L \in \Gamma(\mu^!L_\pi).$$

Using Problem 7.10, the section s has a flow $\Phi_s^t := d\phi_X^t \circ e^{d\beta_t}$, where

$$\beta_t := \int_0^t (\phi_X^\varepsilon)^*\theta_L d\varepsilon.$$

By Problem 7.11, the flow preserves the Dirac structure $\mu^!L_\pi$, and so we have

$$d\phi_X^1 \circ e^{d\beta_1}(\mu^!L_\pi)_\xi = (\mu^!L_\pi)_{\phi_X^1(\xi)}, \quad \forall \xi \in U.$$

Note that $\text{Ker}(d\mu) \subset \mu^!L_\pi$. Using the definition of τ , we obtain

$$\text{Ker}(d\tau)_\xi = (d\phi_X^{-1})(\text{Ker}(d\mu)_{\phi_X^1(\xi)}) \subset (d\phi_X^{-1})((\mu^!L_\pi)_{\phi_X^1(\xi)}) = e^{d\beta_1}(\mu^!L_\pi)_\xi,$$

for all $\xi \in U$. Also, when $t = 1$, we find that

$$\begin{aligned} d\beta_1 &= d \int_0^1 (\phi_X^\varepsilon)^*\theta_L d\varepsilon = \int_0^1 (\phi_X^\varepsilon)^*d\theta_L d\varepsilon \\ &= - \int_0^1 (\phi_X^\varepsilon)^*\omega_{\text{can}} d\varepsilon = -\omega. \end{aligned}$$

We conclude that

$$e^\omega(\text{Ker}(d\tau)_\xi), \text{Ker}(d\mu)_\xi \subset (\mu^!L_\pi)_\xi, \quad \forall \xi \in U.$$

Since $\mu^!L_\pi$ is a Dirac structure, it follows that $\omega(u, v) = 0$ for all $u \in \text{Ker}(d\tau)_\xi$ and $v \in \text{Ker}(d\mu)_\xi$. Thus,

$$\text{Ker}(d\tau)_\xi \subset \text{Ker}(d\mu)_\xi^{\perp\omega} \quad \forall \xi \in U.$$

Since these vector spaces have the same dimension, we obtain (11.15). This concludes the proof. □

Problems

11.1. Let (M, π) be a Poisson manifold, and let $E \rightarrow M$ be a vector bundle.

(a) Given an ordinary connection $\bar{\nabla}$ on E show that the associated contravariant connection $\nabla_\alpha := \bar{\nabla}_{\pi^\sharp(\alpha)}$ satisfies

$$(11.16) \quad \pi^\sharp(\xi) = 0 \quad \implies \quad \nabla_\xi = 0.$$

(b) If (M, π) is a regular Poisson manifold, show that any contravariant connection satisfying (11.16) arises from a usual connection, as in (a).

(c) Show that (b) may fail without the regularity condition.
(HINT: Take $M = \mathbb{R}^2$.)

(d) Show that if a contravariant connection ∇ satisfies (11.16), then for each symplectic leaf $i : S \hookrightarrow (M, \pi)$ there is a unique ordinary connection $\bar{\nabla}^S$ on the pullback bundle $i^*E \rightarrow S$ such that

$$i^*(\nabla_\alpha s) = \bar{\nabla}_{\pi^\sharp(\alpha)}^S(i^*s) \quad (\alpha \in \Omega^1(M), s \in \Gamma(E)).$$

11.2. Let (M, π) be a Poisson manifold, and let $E \rightarrow M$ be a vector bundle. Show that contravariant connections can be glued using partitions of unity: if $\{\sigma_i\}_{i \in I}$ is a locally finite partition of unity subordinate to an open cover $\{U_i\}_{i \in I}$ and the $\nabla^{(i)}$ are contravariant connections on $E|_{U_i}$, then

$$\nabla := \sum_{i \in I} \sigma_i \nabla^{(i)}$$

is a contravariant connection on E .

11.3. Show that every Poisson manifold (M, π) admits a contravariant connection ∇ compatible with π , i.e., such that

$$\nabla_\alpha \pi = 0, \quad \forall \alpha \in \Omega^1(M).$$

11.4. Let (M, π) be a Poisson manifold, and let g be a Riemannian metric. Show that there exists a unique torsion-free contravariant connection on (M, π) compatible with g , i.e., such that

$$\nabla_\alpha g = 0, \quad \forall \alpha \in \Omega^1(M).$$

11.5. Let (E, ∇) be a flat contravariant vector bundle over (M, π) . For any base point $x \in M$, show that E_x is a representation of the isotropy Lie algebra $\mathfrak{g}_x := \text{Ker } \pi_x^\sharp$

$$\rho : \mathfrak{g}_x \rightarrow \mathfrak{gl}(E_x), \quad \xi \mapsto \nabla_\xi.$$

(HINT: You should check first that ρ is well-defined.)

11.6. Let (M, π) be a Poisson manifold with a volume form μ , and let X_μ be the corresponding modular vector field.

- (a) For $H \in C^\infty(M)$ and $x \in M$ such that the flow line of X_H starting at x is defined up to $t = 1$, consider the cotangent path

$$a : [0, 1] \rightarrow T^*M, \quad a(t) := (dH)_{\gamma(t)}, \quad \text{where } \gamma(t) := \phi_{X_H}^t(x),$$

and consider the path of top forms over γ

$$c : [0, 1] \rightarrow \bigwedge^{\text{top}} T^*M, \quad c(t) := (\phi_{X_H}^{-t})^*(\mu_x) \in \bigwedge^{\text{top}} T_{\gamma(t)}^*M.$$

Show that c is parallel along a for the canonical flat contravariant connection on $\bigwedge^{\text{top}} T^*M$ from Example 11.7; i.e., $D_a c = 0$.

- (b) For $H \in C^\infty(M)$ such that X_H is complete, prove the following formula for the Jacobian determinant relative to μ of its flow:

$$(\phi_{X_H}^1)^* \mu = \exp \left(\int_0^1 \mathcal{L}_{X_\mu}(H) \circ \phi_{X_H}^t dt \right) \cdot \mu.$$

(HINT: Use Proposition 11.23.)

11.7. Let (M, π) be a Poisson manifold. Extend the Lie derivative operator along a 1-form $\alpha \in \Omega^1(M)$ from multivector fields to differential forms (see Problem 2.13) by requiring that

$$\mathcal{L}_{\pi^\sharp(\alpha)} \langle \vartheta, \beta \rangle = \langle \mathcal{L}_\alpha \vartheta, \beta \rangle + \langle \vartheta, \mathcal{L}_\alpha \beta \rangle \quad (\vartheta \in \mathfrak{X}^k(M), \beta \in \Omega^k(M)).$$

Show that \mathcal{L}_α is the only linear operator on $\Omega^\bullet(M)$ that satisfies

$$\begin{aligned} \mathcal{L}_\alpha f &= \mathcal{L}_{\pi^\sharp(\alpha)} f, & \mathcal{L}_\alpha \beta &= [\alpha, \beta]_\pi, \\ \mathcal{L}_\alpha(\beta_1 \wedge \beta_2) &= \mathcal{L}_\alpha \beta_1 \wedge \beta_2 + \beta_1 \wedge \mathcal{L}_\alpha \beta_2, \end{aligned}$$

for all $f \in C^\infty(M)$, $\beta \in \Omega^1(M)$, and $\beta_1, \beta_2 \in \Omega^\bullet(M)$.

Moreover, for top degree forms, show that the Lie derivative coincides with the canonical flat contravariant connection on $\bigwedge^{\text{top}} T^*M$, introduced in Example 11.7:

$$\nabla_\alpha \mu = \mathcal{L}_\alpha \mu, \quad \mu \in \Omega^{\text{top}}(M).$$

11.8. Given a Lie algebroid $(A \rightarrow M, [\cdot, \cdot]_A, \rho)$ and a vector bundle $E \rightarrow M$ one defines an A -connection on E to be an \mathbb{R} -bilinear operator

$$\Gamma(A) \times \Gamma(E) \rightarrow \Gamma(E), \quad (\alpha, s) \mapsto \nabla_\alpha s,$$

satisfying

$$\nabla_{f\alpha} s = f \nabla_\alpha s, \quad \nabla_\alpha (fs) = f \nabla_\alpha s + \mathcal{L}_{\rho(\alpha)}(f)s.$$

There are obvious definitions of curvature and torsion (the latter for A -connections on $E = A$). Also, an A -path (see Problem 10.1) is a path $a : [0, 1] \rightarrow A$ with base path $\gamma_a : [0, 1] \rightarrow M$ such that

$$\rho(a(t)) = \frac{d\gamma_a}{dt}(t).$$

- (a) Define parallel transport along A -paths. When $A = T^*M$ for a Poisson manifold (M, π) , or $A = TM$ for any manifold, you should recover the definitions you already know!
- (b) Let (M, π) be a Poisson manifold, let S be a symplectic leaf, and let $(T_S^*M, [\cdot, \cdot]_{T_S^*M}, \pi^\sharp)$ be the restricted cotangent algebroid. In Remark 11.29, we have introduced the following “Bott-type action” of T_S^*M on the conormal bundle $\nu^*(S) = (TS)^\circ$:

$$\Gamma(T_S^*M) \times \Gamma(\nu^*(S)) \rightarrow \Gamma(\nu^*(S)), \quad \nabla_{\alpha s} := [\alpha, s]_{T_S^*M}.$$

Show that this is indeed a flat T_S^*M -connection.

- (c) Show that if S is a regular leaf, then the parallel transport for the connection defined in (b) coincides with linear Poisson holonomy — therefore extending linear Poisson holonomy to nonregular leaves.

11.9. Let (M, π) be a Poisson manifold, and let ∇ be a contravariant connection on (M, π) . Define the exponential map $\exp_\nabla : T^*M \rightarrow M$ by

$$\exp_\nabla(a) := \text{pr}_M(\phi_X^1(a)),$$

where X is the geodesic spray of the connection ∇ . Show the following:

- (a) \exp_∇ is defined on a neighborhood of the zero section.
- (b) For any $x \in M$, the differential at 0_x of the exponential map restricted to the cotangent space $\exp_\nabla|_{T_x^*M}$ is given by

$$d_{0_x} \exp_\nabla|_{T_x^*M} = \pi_x^\sharp.$$

- (c) \exp_∇ yields a submersion from a neighborhood of 0_x in T_x^*M onto a neighborhood of x in the symplectic leaf S containing x .

Notes and References for Part 3

Poisson cohomology was introduced by André Lichnerowicz in his seminal paper [109] and so it is sometimes called Lichnerowicz-Poisson cohomology. He found Poisson cohomology by looking at local versions of the Chevalley-Eilenberg complex of the Lie algebra $(C^\infty(M), \{\cdot, \cdot\})$, and [109] includes comparisons of these cohomology groups. Various versions (formal, analytic, smooth) of Poisson cohomology were used early on in connection with the linearization problem, although not always in complete explicit form — see, e.g., [34, 35, 147]. The first nontrivial computations of Poisson cohomology are due to Vaisman [139, 141] and Vorobjev and Karasev [143, 144], who introduced the spectral sequence and the Mayer-Vietoris sequence for Poisson cohomology, and to Ginzburg and Weinstein [80] who calculated the Poisson cohomology of duals of compact Poisson-Lie groups and, in particular, of linear Poisson structures associated to compact Lie algebras. The techniques developed in [80] influenced many other works and also inspired our discussion on linearization of Poisson structures in Chapter 9. The idea of using Euler-like vector fields in linearization problems is an old one — see, e.g., [85] — and was developed into a systematic method recently by Bursztyn, Lima, and Meinrenken [25]. Note that there are also linearization results not directly using Poisson cohomology, most notably the results on the Ginzburg-Weinstein map by Alekseev and Meinrenken [5, 7] and the earlier results by Dufour [58] inspired by techniques from dynamical systems.

As we have pointed out, in general, finding the full Poisson cohomology ring of a Poisson manifold is a very hard problem, and only very few

examples have been worked out, mostly in low dimensions — see the monograph by Dufour and Zung [59] for an account. Poisson homology (in the sense of Problem 9.13) appears in Koszul [104] and Brylinski [19], but even fewer computations and applications are known. There is also a version of equivariant Poisson cohomology in the presence of a group action, which was introduced and studied by Ginzburg [75, 76]. The modular class of a Poisson manifold was introduced by Koszul in [104] and its geometric interpretation is due to Weinstein [155] — see also [63]. The much more amenable Poisson cohomology relative to a symplectic leaf was introduced by Ginzburg and Lu in [79]. It was also studied by Itskov, Karasev, and Vorobjev [93] and explored in depth to understand the stability of symplectic leaves in [43].

The fact that a Poisson structure determines a Lie algebroid structure on its cotangent bundle was first observed by Coste, Dazord, and Weinstein in [37, 152]. This is the first sign of a deep, far-reaching, relationship between Poisson manifolds and symplectic groupoids, to be studied in Part 4. The identification between Poisson cohomology and Lie algebroid cohomology was pointed out by Huebschmann in [92] and then further explored by Xu [160] to study the Poisson cohomology of regular Poisson structures. Many properties of Poisson cohomology were established exploring this connection — see, e.g., [40, 63, 79, 157, 158].

The notion of cotangent path appeared first in the work of Ginzburg and Golubev [78] to define the linear holonomy of a symplectic leaf of a Poisson manifold. However, they lacked the more subtle notion of cotangent homotopy, which was first introduced in [41, 42] in connection with the integrability problem for Poisson manifolds, to be studied in Part 4. The Poisson homotopy groups also appeared first in [42]. Their central role in understanding global properties of Poisson manifolds became clear in the last 15 years — see, e.g., [46, 47, 49]. The notion of variation of symplectic area was independently discovered by Xu in [160] and Alcalde Cuesta and Hector in [2]. Its relevance for the smoothness of the Poisson homotopy groups was pointed out early on by Weinstein in [151] and plays a central role in [42]. The Poisson homology groups of Chapter 10 were introduced in [36]. Chapter 10 includes several new concepts and results such as the notion of cotangent maps and contravariant Stokes's Theorem, which we have included mostly for pedagogical reasons.

Contravariant connections appeared in the form of contravariant derivatives in Vaisman [140] and were used for constructing a prequantization of a Poisson manifold. Flat contravariant connections (also called representations) on line bundles and their characteristic classes were studied by Evens, Lu, and Weinstein in [63]. The holonomy of a flat connection is defined and studied by Ginzburg and Golubev in [78], where Theorem 11.28 is stated

and proved. A vector bundle with a flat contravariant connection is called a Poisson vector bundle by Ginzburg in [77], where he studies the semiring of isomorphism classes of Poisson vector bundles of a fixed Poisson manifold, i.e., its Poisson K -theory. A systematic study of contravariant connections, their torsion and curvature, parallel transport along cotangent paths, etc., can be found in [65, 66]. Invariance under cotangent path-homotopy was studied in [41, 42]. Contravariant connections show up naturally in different contexts — such as deformation quantization [20] — and have now become a basic tool in the study of global properties of Poisson manifolds.

The existence of symplectic realizations for any Poisson manifold appeared in Karasev [94] and Coste, Dazord, and Weinstein [37]. Their proofs establish first a local uniqueness result and then a gluing argument to obtain a global realization. The simple formula given here has its origin in the path-space approach to the symplectic groupoid [32, 42] and first appeared explicitly in [48], where it was proven using the ideas of contravariant geometry. The proof presented here, using Dirac geometry, is inspired by [72].

Part 4

Symplectic Groupoids

Since a Poisson bracket makes the algebra of smooth functions into a Lie algebra, it is natural to wonder if there is a Lie group integrating this Lie algebra. The theory of infinite-dimensional Lie algebras and Lie groups poses considerable challenges. However, in our case there is a more simple, yet extremely profitable, approach: instead of the Poisson bracket on functions we can consider the associated cotangent Lie algebroid and look for a *finite-dimensional* groupoid integrating it. This groupoid turns out to have a natural symplectic structure. In this last part, we will study how to construct the symplectic groupoid of a Poisson manifold and we will explore the consequences of the groupoid point of view.

Complete Symplectic Realizations

Complete symplectic realizations turn out to play a major role since they provide a bridge between Poisson manifolds and their symplectic groupoids.

Definition 12.1. A symplectic realization $\mu : (S, \omega) \rightarrow (M, \pi)$ is called **complete** if for any complete Hamiltonian vector field $X_H \in \mathfrak{X}(M)$ the Hamiltonian vector field $X_{H \circ \mu} \in \mathfrak{X}(S)$ is also complete.

It is not difficult to see that, for symplectic realizations, one has

$$S \text{ is compact} \implies \mu \text{ is proper} \implies \mu \text{ is complete.}$$

Note that the notion of **complete Poisson map** makes sense for maps between any two Poisson manifolds. This generalizes the notion of a complete Poisson submanifold. The implications above, and in fact many of the results of this chapter, can be adapted to general Poisson maps.

In this chapter, after discussing the infinitesimal action associated to any symplectic realization, we look at examples of complete symplectic realizations for several classes of Poisson manifolds. As we look deeper into these examples, we will slowly unveil the structure of the symplectic groupoid. Inspired by these examples, we then come back to general complete symplectic realizations and clarify the connection with the *Poisson homotopy groupoid*.

12.1. The infinitesimal action

Consider a symplectic realization

$$\mu : (S, \omega) \rightarrow (M, \pi).$$

By Libermann’s Theorem, we have two foliations on S :

- the **vertical foliation** with tangent distribution $\text{Ker } d\mu$,
- the **orbit foliation** with tangent distribution $(\text{Ker } d\mu)^\perp_\omega$.

The name *orbit* foliation is due to the fact that it arises from an “action”

Definition 12.2. The **infinitesimal action** associated with a symplectic realization $\mu : (S, \omega) \rightarrow (M, \pi)$ is the bundle map

$$\mathfrak{a} : \mu^*T^*M \rightarrow TS$$

defined by requiring

$$i_{\mathfrak{a}(\alpha)}\omega = \mu^*\alpha, \quad \forall \alpha \in T^*M.$$

The infinitesimal action can be thought of as follows:

- pointwise, as a linear map $\mathfrak{a}_p : T_{\mu(p)}^*M \rightarrow T_pS$ for each $p \in S$,
- at the level of sections, as a map $\mathfrak{a} : \Omega^1(M) \rightarrow \mathfrak{X}(S)$.

There are several reasons for using the name infinitesimal action. A first reason is that at the level of sections \mathfrak{a} is a Lie algebra map. This and the main properties of \mathfrak{a} are listed in the following:

Proposition 12.3. *Let $\mu : (S, \omega) \rightarrow (M, \pi)$ be a symplectic realization. Then $\mathfrak{a} : \Omega^1(M) \rightarrow \mathfrak{X}(S)$ is a Lie algebra map*

$$\mathfrak{a}([\alpha, \beta]_\pi) = [\mathfrak{a}(\alpha), \mathfrak{a}(\beta)], \quad \forall \alpha, \beta \in \Omega^1(M).$$

Moreover, for each $p \in S$, the action \mathfrak{a}_p has the following properties:

- (i) *It lifts the map π^\sharp ; i.e., the following diagram commutes:*

$$\begin{array}{ccc} & & T_pS \\ & \nearrow \mathfrak{a}_p & \downarrow d\mu \\ T_{\mu(p)}^*M & \xrightarrow{\pi^\sharp} & T_{\mu(p)}M \end{array}$$

- (ii) *It is pointwise free; i.e., $\mathfrak{a}_p : T_{\mu(p)}^*M \rightarrow T_pS$ is injective.*
- (iii) *Its image is precisely the orbit foliation: $\text{Im}(\mathfrak{a}_p) = (\text{Ker } d_p\mu)^\perp_\omega$.*
- (iv) *Its restriction to the isotropy Lie algebra is a linear isomorphism*

$$\mathfrak{a}_p : \mathfrak{g}_{\mu(p)} \xrightarrow{\sim} (\text{Ker } d_p\mu) \cap (\text{Ker } d_p\mu)^\perp_\omega.$$

Proof. Item (i) follows because μ is a Poisson map, and so by the definition of \mathfrak{a}_p we have a commutative diagram

$$\begin{array}{ccc}
 T_p^*S & \xrightarrow{(\omega^b)^{-1}} & T_pS \\
 (d_p\mu)^* \uparrow & \nearrow \mathfrak{a}_p & \downarrow d_p\mu \\
 T_{\mu(p)}^*M & \xrightarrow{\pi^\sharp} & T_{\mu(p)}M
 \end{array}$$

This also shows that \mathfrak{a}_p factors as the composition of an injective map and an isomorphism, so it is injective and (ii) follows. For (iii) observe that the image of \mathfrak{a}_p is given by

$$\text{Im}(\mathfrak{a}_p) = (\omega^b)^{-1}((\text{Ker } d_p\mu)^\circ) = (\text{Ker } d_p\mu)^\perp.$$

Since $\mathfrak{g}_{\mu(p)} = \text{Ker } \pi^\sharp_{\mu(p)}$, the diagram gives $\mathfrak{a}_p(\mathfrak{g}_{\mu(p)}) = \text{Ker } d_p\mu \cap \text{Im}(\mathfrak{a}_p)$, and then (iv) follows from (iii).

To see the \mathfrak{a} is a Lie algebra homomorphism, one first notes that

$$\mathfrak{a}(f\alpha) = (f \circ \mu) \mathfrak{a}(\alpha), \quad \forall f \in C^\infty(M), \alpha \in \Omega^1(M).$$

Using this, the Leibniz identity, and (i), the difference $\mathfrak{a}([\alpha, \beta]_\pi) - [\mathfrak{a}(\alpha), \mathfrak{a}(\beta)]$ is $C^\infty(M)$ -bilinear. So it is enough to check the identity on exact 1-forms. But for these one has $\mathfrak{a}(df) = X_{\mu^*(f)}$ and so, if $\alpha = df$ and $\beta = dg$, then the equation becomes

$$X_{\mu^*(\{f,g\})} = [X_{\mu^*(f)}, X_{\mu^*(g)}],$$

which holds since μ is a Poisson map. □

We will see later how completeness of the symplectic realization can be seen as completeness of the infinitesimal action — similar to the case of Lie algebra actions recalled in Appendix A. An indication of this phenomenon is provided by the following:

Corollary 12.4. *Let $\mu : (S, \omega) \rightarrow (M, \pi)$ be a complete symplectic realization, and let $x \in M$. Then the corresponding infinitesimal action restricts to a complete action of the isotropy Lie algebra at x on the fiber of μ above x :*

$$\mathfrak{a} : \mathfrak{g}_x \rightarrow \mathfrak{X}(\mu^{-1}(x)).$$

In particular, it integrates to a group action of $\Pi(\mathfrak{g}_x)$ on $\mu^{-1}(x)$ where $\Pi(\mathfrak{g}_x)$ is the 1-connected Lie group with Lie algebra \mathfrak{g}_x .

Proof. Write $v \in \mathfrak{g}_x$ as $d_x H$ with H compactly supported. Then $\mathfrak{a}|_{\mathfrak{g}_x} : \mathfrak{g}_x \rightarrow \mathfrak{X}(\mu^{-1}(x))$ sends v to $X_{H \circ \mu}|_{\mu^{-1}(x)}$, which is complete by assumption. The action integrates to one of the Lie group $\Pi(\mathfrak{g}_x)$ — see Proposition A.3. □

Property (iii) shows that the leaves of the orbit foliation can be thought of as the orbits of the infinitesimal action and will therefore be called **orbits**. The compatibility with the brackets immediately gives:

Corollary 12.5. *The fiberwise inverse of the infinitesimal action induces a Lie algebroid map*

$$\Psi : \text{Im}(\mathfrak{a}) = (\text{Ker } d\mu)^{\perp\omega} \rightarrow T^*M, \quad \Psi(v) := \mathfrak{a}^{-1}(v).$$

Hence, for any orbit $\mathcal{O}_p \subset S$ of the action, Ψ restricts to a cotangent map

$$(12.1) \quad \Psi_p : T\mathcal{O}_p \rightarrow T^*M.$$

We also deduce that the orbits of the infinitesimal action are related to the symplectic leaves as follows:

Proposition 12.6. *Let $\mu : (S, \omega) \rightarrow (M, \pi)$ be a symplectic realization. Let \mathcal{O}_p be the orbit of the action through $p \in S$. Then μ maps \mathcal{O}_p to the symplectic leaf $S_{\mu(p)}$ through $\mu(p) \in M$ and $\mu|_{\mathcal{O}_p} : \mathcal{O}_p \rightarrow S_{\mu(p)}$ is a submersion.*

Moreover, we have the following diagram:

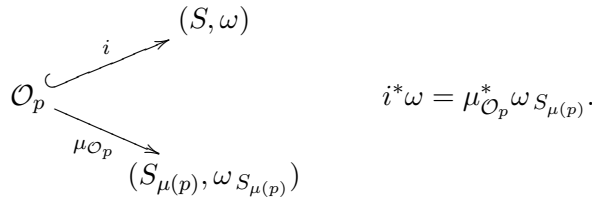

Proof. Corollary 12.5 implies the first part. The second part follows because the Poisson condition gives

$$\omega(\mathfrak{a}(\alpha), \mathfrak{a}(\beta)) = -\pi(\alpha, \beta) = \omega_{S_{\mu(p)}}(\pi^\sharp(\alpha), \pi^\sharp(\beta)). \quad \square$$

12.2. Case study: Linear Poisson structures

We start by looking at general symplectic realizations of a linear Poisson structure $\pi_{\mathfrak{g}}$. It was mentioned already in Example 1.35 that moment maps for \mathfrak{g} -Hamiltonian spaces correspond to Poisson maps $(S, \omega) \rightarrow (\mathfrak{g}^*, \pi_{\mathfrak{g}})$. We will now complete that discussion.

Consider a symplectic realization

$$\mu : (S, \omega) \rightarrow (\mathfrak{g}^*, \pi_{\mathfrak{g}}).$$

The associated infinitesimal action $\mathfrak{a} : \Omega^1(\mathfrak{g}^*) \rightarrow \mathfrak{X}(S)$ restricts to an infinitesimal \mathfrak{g} -action $\mathfrak{a} : \mathfrak{g} \rightarrow \mathfrak{X}(S)$ by interpreting elements in \mathfrak{g} as constant 1-forms. We recover the Lie algebra action from Example 1.35. Notice that the fact that this is a Lie algebra action follows from Proposition 12.3. On the other hand, the moment map condition amounts to the definition of the

action $\mathfrak{a} : \Omega^1(\mathfrak{g}^*) \rightarrow \mathfrak{X}(S)$ and we have the following:

Proposition 12.7. *Let \mathfrak{g} be a Lie algebra. There is a 1-to-1 correspondence*

$$\left\{ \begin{array}{l} \text{symplectic realizations} \\ \mu : (S, \omega) \rightarrow (U, \pi_{\mathfrak{g}}|_U) \\ \text{with } U \subset \mathfrak{g}^* \text{ open} \end{array} \right\} \xleftrightarrow{\sim} \left\{ \begin{array}{l} \text{infinitesimally free} \\ \mathfrak{g}\text{-Hamiltonian} \\ \text{spaces } (S, \omega) \end{array} \right\}.$$

Moreover, μ is a complete realization if and only if the infinitesimal action of \mathfrak{g} comes from an action of the 1-connected Lie group G integrating \mathfrak{g} . In particular, one obtains a 1-to-1 correspondence

$$\left\{ \begin{array}{l} \text{complete symplectic realizations} \\ \mu : (S, \omega) \rightarrow (U, \pi_{\mathfrak{g}}|_U) \\ \text{with } U \subset \mathfrak{g}^* \text{ open } G\text{-invariant} \end{array} \right\} \xleftrightarrow{\sim} \left\{ \begin{array}{l} \text{locally free} \\ G\text{-Hamiltonian} \\ \text{spaces } (S, \omega) \end{array} \right\}.$$

Proof. For the first 1-to-1 correspondence we already observed that by Proposition 12.3 a symplectic realization yields a Lie algebra action and this action is infinitesimally free since \mathfrak{a} is injective. The \mathfrak{g} -equivariance also follows from (i) in Proposition 12.3. For the opposite direction, we observe that the moment map of a \mathfrak{g} -Hamiltonian action is a submersion iff the Lie algebra action is infinitesimally free.

Assume now that $\mu : (S, \omega) \rightarrow (U, \pi_{\mathfrak{g}}|_U)$ is a complete realization of an open G -invariant subset $U \subset \mathfrak{g}^*$. Given $v \in \mathfrak{g}$, the evaluation $\text{ev}_v : \mathfrak{g}^* \rightarrow \mathbb{R}$ yields a Hamiltonian vector field $X_{\text{ev}_v} \in \mathfrak{X}(\mathfrak{g}^*)$, which coincides with the coadjoint action ad_v^* , and hence it is a complete vector field. It follows that

$$\mathfrak{a}(v) = X_{\mu_v} = X_{\mu^*(\text{ev}_v)}$$

is also complete. Therefore, $\mathfrak{a} : \mathfrak{g} \rightarrow \mathfrak{X}(S)$ is a complete Lie algebra action, so it integrates to a locally free G -action of the 1-connected Lie group G — see Proposition A.3.

Conversely, if $\mu : (S, \omega) \rightarrow \mathfrak{g}^*$ is a locally free Hamiltonian G -space, then $\mathfrak{a} : \mathfrak{g} \rightarrow \mathfrak{X}(S)$ is injective so the action is infinitesimally free and μ is a submersion. It follows that its image is an open G -invariant subset $U \subset \mathfrak{g}^*$. We show now that the symplectic realization $\mu : (S, \omega) \rightarrow (U, \pi_{\mathfrak{g}}|_U)$ is complete. Let $H \in C^\infty(U)$ be a smooth function with complete Hamiltonian vector field. We show that for any $p \in S$ the integral curve of $X_{H \circ \mu}$ starting at p is defined on $[0, 1]$. Let $x := \mu(p)$ and denote

$$\gamma(t) := \phi_{X_H}^t(x) : [0, 1] \rightarrow U \quad \text{and} \quad a(t) := d_{\gamma(t)}H : [0, 1] \rightarrow T_{\gamma(t)}^*\mathfrak{g}^* \simeq \mathfrak{g}.$$

By Lemma 10.32, there exists a unique path $g : [0, 1] \rightarrow G$ such that

$$\frac{d}{dt}g(t) = dL_{g(t)}(a(t)), \quad g(0) = e.$$

We claim that

$$\gamma(t) = \text{Ad}_{g(t)^{-1}}^*(x).$$

This follows from the calculation

$$\begin{aligned} \frac{d}{dt} \text{Ad}_{g(t)}^*(\gamma(t)) &= \text{Ad}_{g(t)}^* \left(-\text{ad}_{a(t)}^* |_{\gamma(t)} + \dot{\gamma}(t) \right) \\ &= \text{Ad}_{g(t)}^* \left(-\pi_{\mathfrak{g}}^\# |_{\gamma(t)}(a(t)) + X_H |_{\gamma(t)} \right) = 0. \end{aligned}$$

The result will now follow by showing that the integral curve of $X_{H \circ \mu}$ starting at p is given by

$$\tilde{\gamma}(t) := g(t)^{-1} \cdot p.$$

Since μ is G -equivariant, $\tilde{\gamma}(t)$ covers $\gamma(t)$. Its derivative is

$$\begin{aligned} \frac{d}{dt} \tilde{\gamma}(t) &= \frac{d}{ds} \Big|_{s=t} (g(t)^{-1}g(s))^{-1} \cdot \tilde{\gamma}(t) \\ &= \mathfrak{a}_{\tilde{\gamma}(t)}(a(t)) \\ &= \mathfrak{a}_{\tilde{\gamma}(t)}(d_{\gamma(t)}H) = X_{H \circ \mu} |_{\tilde{\gamma}(t)}. \end{aligned}$$

This concludes the proof. □

Remark 12.8. Notice that the assumption about freeness of the \mathfrak{g} -action is equivalent to the property that μ is a submersion. Omitting that assumption, the first part of the proof establishes the 1-to-1 correspondence stated in Example 1.35.

As a summary of this case study, keep in mind that *any complete symplectic realization of $(\mathfrak{g}^*, \pi_{\mathfrak{g}})$ comes with a Lie group action*

$$\begin{array}{c} G \curvearrowright (S, \omega) \\ \downarrow \mu \\ (\mathfrak{g}^*, \pi_{\mathfrak{g}}) \end{array}$$

12.3. Case study: The zero Poisson structure

We look at an arbitrary manifold M endowed with the zero Poisson structure $\pi \equiv 0$. We already know that it admits the canonical symplectic realization $\text{pr} : (T^*M, \omega_{\text{can}}) \rightarrow (M, 0)$, and we now look at more general ones.

Consider an arbitrary symplectic realization $\mu : (S, \omega) \rightarrow (M, 0)$. Items (iii) and (iv) of Proposition 12.3 imply that the infinitesimal action satisfies

$$\text{Im}(\mathfrak{a}_p) = (\text{Ker } d_p\mu)^{\perp\omega} \subset \text{Ker } d_p\mu.$$

So the fibers of μ are coisotropic submanifolds. The converse also holds.

Proposition 12.9. *A symplectic realization $\mu : (S, \omega) \rightarrow (M, 0)$ is the same thing as a surjective submersion $\mu : (S, \omega) \rightarrow M$ with coisotropic fibers. In particular, if $\dim S = 2 \dim M$, μ is a symplectic realization if and only if its fibers are Lagrangian submanifolds.*

Proof. We already know that one implication holds. For the other one we can invoke, e.g., Libermann’s Theorem. □

For each point $x \in M$, the infinitesimal action restricts to a linear map

$$(12.2) \quad \mathfrak{a} : T_x^*M \rightarrow \mathfrak{X}(\mu^{-1}(x)).$$

Again Proposition 12.3 shows that this map is a Lie algebra action of the abelian Lie algebra T_x^*M on the fiber $\mu^{-1}(x)$. Completeness amounts to integrability of this action.

Proposition 12.10. *A symplectic realization $\mu : (S, \omega) \rightarrow (M, 0)$ is complete if and only if for each $x \in M$ the Lie algebra action (12.2) integrates to an action of the abelian group $(T_x^*M, +)$ on the fiber $\mu^{-1}(x)$.*

Proof. The symplectic realization is complete if and only if all the vector fields $X_{f \circ \mu} = \mathfrak{a}(df)$, with $f \in C^\infty(M)$, are complete. Since these vector fields are vertical, this is equivalent to the vector fields $\mathfrak{a}(\xi) \in \mathfrak{X}(\mu^{-1}(x))$ being complete, for all $x \in M$ and $\xi \in T_x^*M$. By Proposition A.3, this is equivalent to the Lie algebra actions (12.2) integrating to Lie group actions. □

Example 12.11. For the symplectic realization $\mu : (T^*M, \omega_{\text{can}}) \rightarrow (M, 0)$, the associated infinitesimal action is given by

$$\mathfrak{a}_\beta(\alpha) = -\alpha \quad (\alpha, \beta \in T_x M).$$

The minus sign is due to our convention for the canonical symplectic form: $\omega_{\text{can}} = -d\theta_L$. Therefore, this realization is complete and, by our convention (A.6) for differentiating actions, the resulting group action is given by

$$(T_x^*M, +) \times T_x^*M \rightarrow T_x^*M, \quad \alpha \cdot \beta = \alpha + \beta. \quad \text{🐟}$$

Summarizing this case study, note that *the actions from the proposition fit together into a global “action” of the bundle of abelian groups T^*M :*

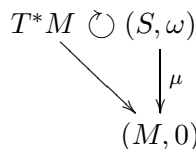

12.4. Case study: Nondegenerate Poisson structures

Next, we consider the other extreme case, when (M, π) is nondegenerate; hence π is obtained by inverting a symplectic form $\omega \in \Omega^2(M)$. Of course, the identity map $\text{Id} : M \rightarrow M$ is a symplectic realization, and so is any surjective local diffeomorphism $\mu : S \rightarrow M$ with the pullback symplectic form $\mu^*\omega$. These are not necessarily complete, and in fact we have:

Proposition 12.12. *If M is a nondegenerate Poisson manifold and $\mu : S \rightarrow M$ is a symplectic realization with $\dim S = \dim M$, then*

$$\mu \text{ is complete} \iff \mu \text{ is a covering map.}$$

This will soon become clear. Note that other symplectic realizations can be obtained by taking products of (M, ω) with another symplectic manifold.

Let us look at the geometry of an arbitrary symplectic realization of a nondegenerate Poisson structure

$$(12.3) \quad \mu : (S, \omega) \rightarrow (M, \pi).$$

By Proposition 12.3, the image of the action $\text{Im}(\mathfrak{a}) = (\text{Ker } d\mu)^\perp$ is an *Ehresmann connection* for $\mu : S \rightarrow M$, i.e., a complement to the vertical distribution

$$(12.4) \quad TS = \text{Ker } d\mu \oplus (\text{Ker } d\mu)^\perp.$$

By Libermann’s Theorem, this connection is *flat*; i.e., $(\text{Ker } d\mu)^\perp \subset TS$ is an involutive distribution. The infinitesimal action can be reinterpreted as the *horizontal lift* with respect to this Ehresmann connection

$$\text{Hor}_p : T_{\mu(p)}M \rightarrow T_pS, \quad \text{Hor}_p(\pi^\sharp\xi) = \mathfrak{a}(\xi).$$

An Ehresmann connection allows one to lift paths from M to S . Given

$$\gamma : [0, 1] \rightarrow M$$

and a point $p \in \mu^{-1}(\gamma(0))$ there is a unique horizontal path $\tilde{\gamma}^p$ starting at p and covering γ ; i.e.,

$$\tilde{\gamma}^p : I \rightarrow S, \quad \text{such that} \quad \begin{cases} \frac{d\tilde{\gamma}^p}{dt}(t) = \text{Hor}_{\tilde{\gamma}^p(t)}(\dot{\gamma}(t)), \\ \tilde{\gamma}^p(0) = p, \end{cases}$$

where, in general, $0 \in I \subset [0, 1]$ is a small interval. The Ehresmann connection is called **complete** if for every curve $\gamma : [0, 1] \rightarrow M$ and any $p \in \mu^{-1}(\gamma(0))$ the horizontal lift $\tilde{\gamma}^p$ is defined on the whole interval $[0, 1]$. The following is a particular case of Theorem 12.22, which we will see later:

Proposition 12.13. *A symplectic realization $\mu : (S, \omega) \rightarrow (M, \pi)$ of a nondegenerate Poisson manifold is complete if and only if the Ehresmann connection $(\text{Ker } d\mu)^\perp$ is complete.*

For a complete Ehresmann connection, given any path γ with $\gamma(0) = x_0$ and $\gamma(1) = x_1$ we have a parallel transport map

$$\tau_\gamma : \mu^{-1}(x_0) \rightarrow \mu^{-1}(x_1), \quad p \mapsto \tilde{\gamma}^p(1).$$

Smoothness of this map follows from standard results on smooth dependence on the parameters of solutions of ODEs. This map is actually a diffeomorphism because, if $\bar{\gamma}(t) = \gamma(1 - t)$ denotes the reverse path, we find

$$\tau_{\bar{\gamma}} \circ \tau_\gamma = \text{Id}_{\mu^{-1}(x_0)}, \quad \tau_\gamma \circ \tau_{\bar{\gamma}} = \text{Id}_{\mu^{-1}(x_1)}.$$

Also, if a smooth path is the concatenation of two paths, parallel transport is transformed into composition of parallel transports:

$$\tau_{\delta \circ \gamma} = \tau_\delta \circ \tau_\gamma.$$

Even more, since the connection is flat, it follows that path-homotopic paths induce the same parallel transport:

$$\gamma_0 \sim \gamma_1 \implies \tau_{\gamma_0} = \tau_{\gamma_1}.$$

If you are not familiar with these properties, the proofs are similar to the ones given in Section 12.5 for parallel transport along cotangent paths — however, our discussion there does not depend on these results.

The decomposition (12.4) also implies that the two complementary foliations are symplectic; i.e., the fibers of μ and the orbits of the infinitesimal action \mathcal{a} are symplectic submanifolds. Moreover, the parallel transport is by symplectomorphisms. Therefore, under mild topological conditions on M , the geometry of complete symplectic realizations can be made completely explicit:

Proposition 12.14. *Let (M, π) be a nondegenerate, 1-connected Poisson manifold. Then any complete symplectic realization $\mu : (S, \omega) \rightarrow (M, \pi)$ is isomorphic to a product; i.e., there exists a symplectomorphism*

$$\Phi : (S, \omega) \xrightarrow{\simeq} (M, \pi) \times (F, \omega_F)$$

under which μ becomes the projection.

Proof. Fix $x_0 \in M$, and set $F = \mu^{-1}(x_0)$ and $\omega_F := \omega|_F$. Define

$$\Phi : S \rightarrow M \times F, \quad \Phi(p) = (\mu(p), \tau_\gamma(p)),$$

where γ is any path in M starting at $\mu(p)$ and ending at x_0 . Since M is 1-connected, this is well-defined. We leave it as an exercise to check that this is the desired symplectomorphism. \square

Exercise 12.15. Modify the previous proof to deduce Proposition 12.12.

To summarize this discussion in a manner similar to the previous two case studies, we rephrase it as follows. First of all, for any two points $x, y \in M$, we consider path-homotopy classes of paths starting at x and ending at y :

$$\Pi(M, y, x) := \frac{\text{paths in } M \text{ from } x \text{ to } y}{\text{path-homotopy}}.$$

Concatenation of paths induces a group-like multiplication

$$\begin{aligned} \Pi(M, z, y) \times \Pi(M, y, x) &\rightarrow \Pi(M, z, x), \\ ([\delta], [\gamma]) &\mapsto [\delta] \circ [\gamma] := [\delta \circ \gamma]. \end{aligned}$$

All these together form the so-called **homotopy groupoid** of M

$$\Pi(M) := \frac{\text{paths in } M}{\text{path-homotopy}} \begin{array}{c} \xrightarrow{\mathbf{t}} \\ \xleftarrow{\mathbf{s}} \end{array} M$$

where the maps \mathbf{s} (for “source”) and \mathbf{t} (for “target”) give the initial and the end points of a path:

$$\begin{aligned} \mathbf{s} : \Pi(M) &\rightarrow M, & [\gamma] &\mapsto \gamma(0), \\ \mathbf{t} : \Pi(M) &\rightarrow M, & [\gamma] &\mapsto \gamma(1). \end{aligned}$$

The multiplication $[\delta] \circ [\gamma]$ is defined only when $\mathbf{s}([\delta]) = \mathbf{t}([\gamma])$.

Now, the previous discussion concerning parallel transport yields an action of $\Pi(M)$ on S along the μ -fibers. For any $x, y \in M$, one sets

$$\Pi(M, y, x) \times \mu^{-1}(x) \rightarrow \mu^{-1}(y), \quad ([\gamma], p) \mapsto [\gamma] \cdot p := \tau_\gamma(p),$$

and these satisfy the following action-like properties:

- (i) The class of the constant path $\gamma(t) \equiv x$ acts as an identity:

$$[x] \cdot p = p, \quad \forall p \in \mu^{-1}(x).$$

- (ii) Whenever $[\delta], [\gamma] \in \Pi(M)$ are composable one has

$$([\delta] \circ [\gamma]) \cdot p = [\delta] \cdot ([\gamma] \cdot p).$$

In the next chapter we will discuss groupoids in depth and this will be referred to as an *action of $\Pi(M) \rightrightarrows M$ on the map $\mu : S \rightarrow M$* .

Therefore, summarizing this discussion, *any complete symplectic realization of a nondegenerate Poisson manifold carries a canonical action of the homotopy groupoid:*

$$\begin{array}{ccc} \Pi(M) & \curvearrowright & (S, \omega) \\ & \searrow & \downarrow \mu \\ & & (M, \pi) \end{array}$$

12.5. Completeness

Note that item (i) in Proposition 12.3 yields the commutative diagram

$$\begin{array}{ccc}
 \mu^*T^*M & \xrightarrow{\mathfrak{a}} & TS \\
 \downarrow & & \downarrow d\mu \\
 T^*M & \xrightarrow{\pi^\sharp} & TM
 \end{array}$$

This suggests that one should think of the infinitesimal action as a “horizontal lift” of covectors in M to tangent vectors in S . Pursuing this point of view, one is led to an operation of “horizontal lift” of cotangent paths. We formalize this as follows:

Definition 12.16. Let $\mu : (S, \omega) \rightarrow (M, \pi)$ be a symplectic realization. A **lift of a cotangent path** $a : I \rightarrow T^*M$ to S is any path $\tilde{\gamma}_a : I \rightarrow S$, such that

$$\frac{d\tilde{\gamma}_a}{dt}(t) = \mathfrak{a}_{\tilde{\gamma}_a(t)}(a(t)), \quad \forall t \in I.$$

Equivalently, by the definition of the infinitesimal action, the equation for the lift can be written as

$$i_{\frac{d\tilde{\gamma}_a}{dt}}\omega = (d\tilde{\gamma}_a\mu)^*a.$$

Exercise 12.17. Show that a path $\tilde{\gamma} : I \rightarrow S$ is a lift of some (necessarily unique!) cotangent path $a : I \rightarrow T^*M$ if and only if

$$\frac{d\tilde{\gamma}}{dt}(t) \in (\text{Ker } d\mu)^\perp, \quad \forall t \in I.$$

As for classical Ehresmann connections, we have:

Proposition 12.18. Let $\mu : (S, \omega) \rightarrow (M, \pi)$ be a symplectic realization. Given a cotangent path $a : [0, 1] \rightarrow T^*M$ and an initial point $p \in \mu^{-1}(\gamma_a(0))$, there exists a unique maximal lift $\tilde{\gamma}_a^p : I \rightarrow S$ of a starting at p , which is defined on some interval $0 \in I \subset [0, 1]$.

Proof. By Lemma 10.3, there exists a smooth family of functions $\{H_t\}_{t \in [0,1]}$ such that $a(t) = dH_t|_{\gamma_a(t)}$ and $\gamma_a(t)$ is an integral curve of X_{H_t} ; i.e., $\gamma_a(t) = \phi_{X_H}^t(\gamma_a(0))$. Let $\tilde{\gamma}_a^p(t) = \phi_{X_{H \circ \mu}}^t(p) : I \rightarrow S$ be the maximal integral curve of the time-dependent Hamiltonian vector field $X_{H_t \circ \mu}$ starting at p . Since $X_{H_t \circ \mu}$ projects to X_{H_t} , it follows that $\mu \circ \tilde{\gamma}_a^p(t) = \gamma_a(t)$. We have that $\tilde{\gamma}_a^p$ is a lift of a :

$$\frac{d\tilde{\gamma}_a^p}{dt}(t) = X_{H_t \circ \mu}|_{\tilde{\gamma}_a^p(t)} = \mathfrak{a}_{\tilde{\gamma}_a^p(t)}(dH_t|_{\gamma_a(t)}) = \mathfrak{a}_{\tilde{\gamma}_a^p(t)}(a(t)).$$

These equations, read in a different order, reveal that *any* lift $\tilde{\gamma} : J \rightarrow S$ of a is an integral curve of $X_{H_t \circ \mu}$:

$$\frac{d\tilde{\gamma}}{dt}(t) = \alpha_{\tilde{\gamma}(t)}(a(t)) = \alpha_{\tilde{\gamma}(t)}(dH_t|_{\gamma_a(t)}) = X_{H_t \circ \mu}|_{\tilde{\gamma}(t)}.$$

So the uniqueness of the maximal lift follows from the corresponding property of integral curves of time-dependent vector fields. \square

Exercise 12.19. If $a : [0, 1] \rightarrow S$ is a cotangent path, show that the pullback bundle $\gamma_a^*S \rightarrow [0, 1]$ has an induced Ehresman connection and that the lifts of a can be interpreted as the parallel transport with respect to this connection — see Exercise 11.15 for the linear version.

It is hard not to notice the striking similarity between the operations of lifting of cotangent paths for a symplectic realization, from the previous proposition, and the lifting of ordinary paths for an Ehresmann connection, discussed in the last case study. These are indeed instances of a very general notion of lifting operation for nonlinear connections on Lie algebroids, as we explain in the following remark.

Remark 12.20 (Nonlinear connections). Let $(A, [\cdot, \cdot]_A, \rho)$ be a Lie algebroid, and let $p : P \rightarrow M$ be a surjective submersion. A **nonlinear A-connection** on P is a vector bundle map covering Id_P ,

$$h_P : p^*A \equiv A \times_M P \rightarrow TP,$$

that makes the following diagram commute:

$$(12.5) \quad \begin{array}{ccc} p^*A & \xrightarrow{h_P} & TP \\ \text{pr} \downarrow & & \downarrow \text{dp} \\ A & \xrightarrow{\rho} & TM \end{array}$$

Given a nonlinear A -connection h_P , let $a : [0, 1] \rightarrow A$ be an A -path with base path $\gamma_a : [0, 1] \rightarrow M$ — see Problem 10.1. For a point $x \in P_{\gamma_a(0)}$, one defines the **horizontal lift** $\tilde{\gamma}_a^x : [0, \varepsilon) \rightarrow P$ to be the unique path over γ_a that satisfies the ODE

$$\begin{cases} \frac{d\tilde{\gamma}_a^x}{dt}(t) = h_P(a(t), \tilde{\gamma}_a^x(t)), \\ \tilde{\gamma}_a^x(0) = x. \end{cases}$$

One calls h_P a **complete** nonlinear A -connection if the horizontal lifts of any cotangent path are defined up to time 1. For a complete connection one defines a **parallel transport** map between the fibers of p :

$$\tau_a : P_{\gamma_a(0)} \rightarrow P_{\gamma_a(1)}, \quad x \mapsto \tilde{\gamma}_a^x(1).$$

For example, if $p : P \rightarrow M$ is proper, then any nonlinear connection h_P is complete.

With these notions at hand, one can explain the similarity between the operations of lifts of paths and cotangent paths. These lifting operations are obtained by considering the appropriate Lie algebroids:

- (i) When $A = TM$ with $\rho = \text{Id}$ it follows from the diagram (12.5) that a nonlinear connection is completely determined by its image, which is a distribution complementary to the vertical distribution $\text{Ker } dp$. So for $A = TM$, nonlinear connections are the same as Ehresmann connections.
- (ii) When $A = T^*M$ is the cotangent algebroid of a Poisson manifold (M, π) , we have $\rho = \pi^\sharp$. In general, π^\sharp has kernel and a nonlinear connection

$$h_P : p^*T^*M \rightarrow TP$$

is not anymore determined by its image. In this case, we call h_P a **contravariant nonlinear connection**.

- (iii) Any symplectic realization $\mu : (S, \omega) \rightarrow (M, \pi)$ comes with a canonical contravariant nonlinear connection, namely the infinitesimal action

$$h_S = a : \mu^*T^*M \rightarrow TS.$$

You may also wonder about the name *nonlinear* connection. This is explained in the following exercise.

Exercise 12.21. Assume that $P = E$ is a vector bundle $p : E \rightarrow M$. Then note that both vertical arrows in (12.5) are naturally vector bundles — e.g., fiber addition on $dp : TE \rightarrow TM$ is obtained by differentiating that on $p : E \rightarrow M$. An A -connection h_E is called **linear** if h_E is a vector bundle map for these vector bundle structures. Show the following:

- (a) A linear connection h_E is always complete.
- (b) Parallel transport τ_a is a linear isomorphism.

For an A -path $a : [0, 1] \rightarrow A$ and a path $c : [0, 1] \rightarrow E$ above $\gamma_a : [0, 1] \rightarrow M$ one defines

$$D_a c(t) := \lim_{h \rightarrow 0} \frac{1}{h} \left((\tau_a^{t, t+h})^{-1} c(t+h) - c(t) \right),$$

where $\tau_a^{t, t+h}$ denotes parallel transport along the restriction $a|_{[t, t+h]}$. Show that D_a is the derivative along A -paths associated to a unique A -connection ∇ on $E \rightarrow M$ in the sense of Problem 11.8. 

Completeness of symplectic realizations can be equivalently characterized in terms of the completeness of the corresponding nonlinear connection.

Theorem 12.22. *A symplectic realization $\mu : (S, \omega) \rightarrow (M, \pi)$ is complete if and only if, for every cotangent path $a : [0, 1] \rightarrow T^*M$ and every initial point $p \in \mu^{-1}(\gamma_a(0))$, the maximal lift $\tilde{\gamma}_a^p$ is defined on $[0, 1]$.*

Proof. Assume first that all maximal lifts are defined on $[0, 1]$. Consider a function $H \in C^\infty(M)$ with complete Hamiltonian vector field X_H . Then for each $x \in M$ the flow of X_H yields a cotangent path $a(t) := d_{\gamma(t)}H$, where $\gamma(t) = \phi_{X_H}^t(x)$. By the proof of Proposition 12.18, the lift $\tilde{\gamma}_a^p : [0, 1] \rightarrow S$ of a starting at $p \in \mu^{-1}(x)$ is precisely the integral curve of $X_{H \circ \mu}$ starting at p . Since lifts exist, $X_{H \circ \mu}$ is complete. So the realization is complete.

To prove the converse, i.e., that cotangent paths can be lifted, we start by making a few remarks:

- It is enough to prove existence of lifts for all symplectic realizations $\mu : (S, \omega) \rightarrow M$ satisfying the (apparently) weaker property

$$H \in C^\infty(M) \text{ compactly supported} \implies X_{H \circ \mu} \text{ is complete.}$$

Moreover, if $\mu : S \rightarrow M$ satisfies this property, then for any open $U \subset M$ the restriction $\mu : \mu^{-1}(U) \rightarrow U$ still satisfies this property.

- It suffices to show that each point in M has a neighborhood U over which cotangent paths can be lifted. Indeed, given any cotangent path $a : [0, 1] \rightarrow T^*M$, one can cover the base path γ_a with a finite number of open sets U_i where lifts exist, and then the lifts of a over each U_i glue smoothly to a lift of a defined on $[0, 1]$.

Hence, we can replace M by the domain of a splitting chart

$$U = (L, \pi_{\text{can}}) \times (X, \pi_X), \quad 0 \in L \subset \mathbb{R}^{2n}, \quad 0 \in X \subset \mathbb{R}^q,$$

where π_X vanishes at 0. Here $L \equiv L \times \{0\} \hookrightarrow M$ is an embedded symplectic leaf and the splitting allows us to identify the isotropy Lie algebras at all points of L :

$$\mathfrak{g} := \text{Ker } \pi_{y,0}^\# \quad (y \in L).$$

Restricting the infinitesimal action \mathfrak{a} , we obtain a Lie algebra action of \mathfrak{g} on $\mu^{-1}(0)$, which we denote by the same symbol:

$$\mathfrak{a} : \mathfrak{g} \rightarrow \mathfrak{X}(\mu^{-1}(0)), \quad \mathfrak{a}_p(\xi) := \mathfrak{a}_p(0, \xi) \quad (p \in \mu^{-1}(0), \xi \in \mathfrak{g}).$$

The splitting also gives a flat Ehresmann connection on $\mu^{-1}(L) \rightarrow L$, with horizontal lift defined by

$$(12.6) \quad \text{Hor} : \mu^*(TL) \rightarrow T\mu^{-1}(L), \quad \text{Hor}_p(\pi_{\text{can}}^\# \alpha) := \mathfrak{a}_p(\alpha, 0) \quad (\alpha \in T_{\mu(p)}^*L).$$

By Proposition 12.3(i) this is an Ehresmann connection. It is flat because both $\pi_{\text{can}}^\# : \Omega^1(L) \xrightarrow{\sim} \mathfrak{X}(L)$ and $\mathfrak{a} : \Omega^1(M) \rightarrow \mathfrak{X}^1(S)$ preserve the Lie brackets — see Proposition 12.3 — and so does the map $\alpha \mapsto (\alpha, 0)$.

Next, we claim that there exists a trivialization Φ of μ over an open set $0 \in V \subset L$,

$$\begin{array}{ccc} V \times \mu^{-1}(0) & \xrightarrow{\Phi} & \mu^{-1}(V) \\ & \searrow \text{pr}_L & \swarrow \mu \\ & & V \end{array}$$

which has the property that it trivializes the action, i.e., that satisfies for all $y \in V$ and $p \in \mu^{-1}(V)$

$$(12.7) \quad d_{(y,p)}\Phi(\pi_{\text{can}}^\# \alpha, \mathfrak{a}_p(\xi)) = \mathfrak{a}_{\Phi(y,p)}(\alpha, \xi) \quad (\alpha \in T_y^*L, \xi \in \mathfrak{g}).$$

To see this, fix a convex neighborhood $V \subset L$ of $0 \in L$ and for each $y \in V$ denote by H^y the unique linear function H^y on (L, π_{can}) whose Hamiltonian flow sends 0 to y . We extend these functions to $L \times X$ to be constant in the second variable. Using a bump function in $L \times X$ which equals 1 in a neighborhood of $V \times \{0\}$ we make all the H^y with compact support. Hence, keeping the same notation, the vector fields $X_{H^y \circ \mu}$ are complete and we can define

$$(12.8) \quad \Phi : V \times \mu^{-1}(0) \rightarrow \mu^{-1}(L), \quad \Phi(y, p) := \phi_{X_{H^y \circ \mu}}^1(p).$$

Notice that the integral curves of $X_{H^y \circ \mu}$ cover the integral curves of X_{H^y} so Φ fits in the previous commutative diagram. Hence, Φ is a diffeomorphism onto $\mu^{-1}(V)$ with inverse

$$\Phi^{-1}(q) = \phi_{X_{H^y \circ \mu}}^{-1}(q), \quad \text{where } y := \mu(q).$$

We still need to show that Φ satisfies (12.7) for any (α, ξ) :

- Assume $\xi = 0$: By definition (12.6) of the flat Ehresmann connection, we have $X_{H^y \circ \mu} = \text{Hor } X_{H^y}$ in $\mu^{-1}(V)$. It follows that $\Phi(V \times \{p\})$ is included in a leaf of the corresponding horizontal foliation. Therefore $d_{(y,p)}\Phi(\pi_{\text{can}}^\# \alpha, 0)$ is horizontal, and by (12.8) this vector projects to $\pi_{\text{can}}^\# \alpha$. We conclude that

$$d_{(y,p)}\Phi(\pi_{\text{can}}^\# \alpha, 0) = \text{Hor}_{\Phi(y,p)}(\pi_{\text{can}}^\# \alpha) = \mathfrak{a}_{\Phi(y,p)}(\alpha, 0).$$

- Assume $\alpha = 0$: Given $\xi \in \mathfrak{g}$, write $\xi = d_0 f$ for some $f \in C^\infty(X)$. Extending f to $L \times X$ as a constant function in the first variable, we have $\{H^y, f\} = 0$, for all $y \in L$. Since μ is a Poisson map, the vector fields $X_{H^y \circ \mu}$ and $X_{f \circ \mu}$ commute. This implies that the flow of $X_{H^y \circ \mu}$ preserves $X_{f \circ \mu} = \mathfrak{a}(df)$, and so

$$\begin{aligned} d_{(y,p)}\Phi(0, \mathfrak{a}_p(\xi)) &= d_{(y,p)}\Phi(0, \mathfrak{a}_p(d_0 f)) \\ &= \mathfrak{a}_{\Phi(y,p)}(0, d_0 f) = \mathfrak{a}_{\Phi(y,p)}(0, \xi). \end{aligned}$$

This shows that Φ has the desired properties. Note that, by assumption, the action of \mathfrak{g} on $\mu^{-1}(0)$ is complete (see Corollary 12.4). Therefore, by Proposition A.3 it comes from a Lie group action $G \times \mu^{-1}(0) \rightarrow \mu^{-1}(0)$ of a 1-connected Lie group G with Lie algebra \mathfrak{g} .

We can now show that any cotangent path $a : [0, 1] \rightarrow T_L^*M$ can be lifted. We decompose the path according to the splitting

$$a(t) = (\alpha(t), \xi(t)), \quad \text{where} \quad \pi_{\text{can}}^\# \alpha(t) = \frac{d\gamma_a}{dt}(t), \quad \xi : [0, 1] \rightarrow \mathfrak{g}.$$

By Lemma 10.32, there exists a unique path $g : [0, 1] \rightarrow G$ such that

$$\left. \frac{d}{ds} \right|_{s=t} g(t)^{-1}g(s) = \xi(t), \quad g(0) = e.$$

We claim that for $q \in \mu^{-1}(\gamma_a(0))$ the lift of a at q is given by

$$\tilde{\gamma}_a^q(t) := \Phi(\gamma_a(t), g(t)^{-1} \cdot p), \quad \text{where } q = \Phi(\gamma_a(0), p).$$

This follows by a computation. First of all,

$$\frac{d}{dt}g(t)^{-1} \cdot p = \left. \frac{d}{ds} \right|_{s=t} (g(t)^{-1}g(s))^{-1} \cdot (g(t)^{-1} \cdot p) = \mathfrak{a}_{g(t)^{-1}, p}(\xi(t)).$$

Then, using (12.7) we obtain that $\tilde{\gamma}_a^q(t)$ is indeed the lift of a :

$$\begin{aligned} \frac{d}{dt}\Phi(\gamma_a(t), g(t)^{-1} \cdot p) &= d_{\Phi(\gamma_a(t), g(t)^{-1}, p)}\Phi(\pi_V^\# \alpha(t), \mathfrak{a}_{g(t)^{-1}, p}(\xi(t))) \\ &= \mathfrak{a}_{\Phi(\gamma_a(t), g(t)^{-1}, p)}(\alpha(t), \xi(t)) \\ &= \mathfrak{a}_{\Phi(\gamma_a(t), g(t)^{-1}, p)}(a(t)). \end{aligned}$$

Moreover, this shows that the lift is defined for all $t \in [0, 1]$. □

In the literature, complete symplectic realizations are defined in various ways. We prove now that these different approaches are all equivalent:

Corollary 12.23. *For a symplectic realization $\mu : (S, \omega) \rightarrow (M, \pi)$ the completeness assumption is equivalent to any of the following conditions:*

- (i) $\{X_{H_t}\}_{t \in [0,1]}$ is complete $\Rightarrow \{X_{H_t \circ \mu}\}_{t \in [0,1]}$ is complete,
- (ii) $\{X_{H_t}\}_{t \in [0,1]}$ is compactly supported $\Rightarrow \{X_{H_t \circ \mu}\}_{t \in [0,1]}$ is complete,
- (iii) $\{\pi^\# \alpha_t\}_{t \in [0,1]}$ is complete $\Rightarrow \{\mathfrak{a}(\alpha_t)\}_{t \in [0,1]}$ is complete,
- (iv) $\{\pi^\# \alpha_t\}_{t \in [0,1]}$ is compactly supported $\Rightarrow \{\mathfrak{a}(\alpha_t)\}_{t \in [0,1]}$ is complete,

where $H_t \in C^\infty(M)$ denotes any smooth family of functions, $\alpha_t \in C^\infty(M)$ denotes any smooth family of 1-forms, and compactly supported time-dependent vector fields are defined as in Section A.3.

Proof. Any compactly supported time-dependent vector field is complete — see Proposition A.12. Therefore, (i) \Rightarrow (ii) and (iii) \Rightarrow (iv). By taking

$\alpha_t = dH_t$, we clearly also have that (iii) \Rightarrow (i) and (iv) \Rightarrow (ii). So, we are left with proving the implications

$$(ii) \implies \text{completeness} \implies (iii).$$

Assume that (ii) holds, and we check the equivalent condition for completeness from Theorem 12.22. By Lemma 10.3, for any cotangent path $a : [0, 1] \rightarrow T^*M$ there exists a smooth family of functions $\{H_t\}_{t \in [0,1]}$, all supported in the same compact set, such that $a(t) = dH_t|_{\gamma_a(t)}$ and $\gamma_a(t) = \phi_{X_H}^t(\gamma_a(0))$. By (ii), $X_{H_t \circ \mu}$ is a complete vector field, so its integral curve $\tilde{\gamma}_a^p(t) = \phi_{X_{H \circ \mu}}^t(p)$ starting at $p \in \mu^{-1}(\gamma_a(0))$ exists for all $t \in [0, 1]$. By the proof of Proposition 12.18, this is precisely the lift of a starting at p . We obtained completeness.

Assume now that the connection is complete. To check (iii), consider a time-dependent section $\alpha_t \in \Omega^1(M)$ such that $\pi^\# \alpha_t$ is a complete vector field. We need to show that for any $p \in S$ the integral curve of $\mathcal{a}(\alpha_t)$ starting at p exists for all $t \in [0, 1]$. The integral curve $\gamma(t)$ of $\pi^\# \alpha_t$ starting at $\mu(p)$ satisfies

$$\frac{d}{dt} \gamma(t) = \pi^\# \alpha_t|_{\gamma(t)}.$$

Therefore, $a(t) := \alpha_t|_{\gamma(t)} : [0, 1] \rightarrow T^*M$ is a cotangent path. Since the connection is complete, Theorem 12.22 implies that $a(t)$ has a complete lift $\tilde{\gamma}_a^p : [0, 1] \rightarrow S$ that starts at p . Note that $\tilde{\gamma}_a^p$ satisfies

$$\frac{d}{dt} \tilde{\gamma}_a^p(t) = \mathcal{a}_{\tilde{\gamma}_a^p(t)}(\alpha_t),$$

and so it is the integral curve of $\mathcal{a}(\alpha_t)$ starting at p . Hence, (iii) holds. \square

12.6. The Poisson homotopy groupoid

The previous section shows that, given a complete symplectic realization $\mu : (S, \omega) \rightarrow (M, \pi)$, any cotangent path $a : [0, 1] \rightarrow T^*M$ yields an operation of **parallel transport**

$$\tau_a : \mu^{-1}(\gamma_a(0)) \rightarrow \mu^{-1}(\gamma_a(1)), \quad p \mapsto \tilde{\gamma}_a^p(1).$$

Next, we show that parallel transport is invariant under cotangent path-homotopy.

Theorem 12.24. *Let $\mu : (S, \omega) \rightarrow (M, \pi)$ be a complete symplectic realization. Let $a, b : [0, 1] \rightarrow T^*M$ be cotangent paths with $\gamma_a(0) = \gamma_b(0) =: x$, and fix $p \in \mu^{-1}(x)$. Let \mathcal{O}_p be the orbit of the infinitesimal action through p . Then a and b are cotangent path-homotopic if and only if their lifts $\tilde{\gamma}_a^p, \tilde{\gamma}_b^p : [0, 1] \rightarrow S$ are path-homotopic inside \mathcal{O}_p .*

Remark 12.25. The theorem gives a geometric interpretation of cotangent path-homotopy on a Poisson manifold in terms of ordinary path-homotopy, once one finds a *complete* symplectic realization. This raises the important question of finding complete symplectic realizations — the symplectic realizations constructed in Theorem 11.43 are rarely complete. We will come back to this problem in the next chapters.

Proof. We assume first that $\tilde{\gamma}_a^p$ and $\tilde{\gamma}_b^p$ are path-homotopic inside \mathcal{O}_p as in the statement. Fix a path-homotopy $H : [0, 1] \times [0, 1] \rightarrow \mathcal{O}_p$, so that

$$H(t, 0) = \tilde{\gamma}_a^p(t), \quad H(t, 1) = \tilde{\gamma}_b^p(t), \quad H(0, \cdot) = \text{const}_0, \quad H(1, \cdot) = \text{const}_1.$$

Viewing $dH : T([0, 1] \times [0, 1]) \rightarrow T\mathcal{O}_p$ as a Lie algebroid map and composing it with the map $\Psi_p : T\mathcal{O}_p \rightarrow T^*M$ from (12.1), we obtain a cotangent map

$$\Phi = \Phi_1 dt + \Phi_2 d\varepsilon : T([0, 1] \times [0, 1]) \rightarrow T^*M.$$

The boundary conditions in Definition 10.18 hold because, for $i \in \{0, 1\}$,

$$H(i, \cdot) = \text{const}_i \implies \frac{dH}{d\varepsilon}(i, \varepsilon) = 0 \implies \Phi_2(i, \cdot) = 0$$

and

$$\begin{aligned} H(t, 0) = \tilde{\gamma}_a^p(t) &\implies \Phi_1(t, 0) = \Psi_p(\dot{\tilde{\gamma}}_a^p(t)) = a(t), \\ H(t, 1) = \tilde{\gamma}_b^p(t) &\implies \Phi_1(t, 1) = \Psi_p(\dot{\tilde{\gamma}}_b^p(t)) = b(t). \end{aligned}$$

Therefore, Φ is a cotangent path-homotopy between a and b .

In order to prove the converse, let

$$\Phi = \Phi_1 dt + \Phi_2 d\varepsilon$$

be a cotangent path-homotopy between the cotangent paths a and b , covering a path-homotopy $\gamma : [0, 1] \times [0, 1] \rightarrow M$. For each ε , $s \mapsto \Phi_1(s, \varepsilon)$ is a cotangent path that can be lifted to a path $H(\cdot, \varepsilon)$ in \mathcal{O}_p , starting at p . We get a smooth map

$$H : [0, 1] \times [0, 1] \rightarrow \mathcal{O}_p$$

sitting above $\gamma : [0, 1] \times [0, 1] \rightarrow M$ and which, by construction, satisfies

$$\frac{dH}{dt}(t, \varepsilon) = \omega_{H(t, \varepsilon)}\Phi_1(t, \varepsilon), \quad H(0, \varepsilon) = p,$$

and by definition

$$H(t, 0) = \tilde{\gamma}_a^p(t) \quad H(t, 1) = \tilde{\gamma}_b^p(t).$$

As in the first part, consider the cotangent map $\Phi' := \Psi_p \circ dH$. We know that $\Phi'_1 = \Phi_1$. We claim that $\Phi'_2 = \Phi_2$. For this, note that the equation in Proposition 10.17(ii) is satisfied both by Φ and Φ' . Therefore, the difference

$$D_\varepsilon(t) := \Phi_2(t, \varepsilon) - \Phi'_2(t, \varepsilon)$$

satisfies for each ε and each vector field X the differential equation

$$\frac{d}{dt} \langle X, D_\varepsilon(t) \rangle = d_\pi(X)(\Phi_1, D_\varepsilon(t)).$$

Writing this for a local basis of vector fields, we obtain that D_ε satisfies locally a linear ODE in t . Therefore, if D_ε vanishes at a point, then it must vanish around that point. Since the vanishing set is also closed and $D_\varepsilon(0) = \Phi_2(0, \varepsilon) - \Phi'_2(0, \varepsilon) = 0 - 0$, we must have $D_\varepsilon = 0$. So $\Phi_2 = \Phi'_2$.

Finally, since $0 = \Phi_2(1, \varepsilon) = \Phi'_2(1, \varepsilon)$ and Ψ_p is a fiberwise isomorphism, it follows that $\frac{d}{d\varepsilon} H(1, \varepsilon) = 0$. Hence $H(1, \varepsilon)$ is constant, showing that H is a path-homotopy between the lifts $\tilde{\gamma}_a^p$ and $\tilde{\gamma}_b^p$. \square

Corollary 12.26. *Let $\mu : (S, \omega) \rightarrow (M, \pi)$ be a complete symplectic realization. If $a, b : [0, 1] \rightarrow T^*M$ are cotangent path-homotopic, then they induce the same parallel transport: $\tau_a = \tau_b$.*

Remark 12.27 (Flat nonlinear connections). When a complete Ehresmann connection is *flat*, i.e., its horizontal distribution is involutive, then path-homotopic paths induce the same parallel transport. The previous corollary states that a similar fact holds for the infinitesimal action associated with a complete symplectic realization. As we discussed in Remark 12.20, both of these are instances of nonlinear connections on a Lie algebroid.

In general, a **flat nonlinear A -connection** $h_S : p^*A \rightarrow TS$ is a nonlinear connection for which the induced map at the level of sections

$$h_S : \Gamma(A) \rightarrow \mathfrak{X}(S),$$

preserves Lie brackets

$$h_S([\alpha_1, \alpha_2]_A) = [h_S(\alpha_1), h_S(\alpha_2)] \quad (\alpha_1, \alpha_2 \in \Gamma(A)).$$

A flat nonlinear A -connection is often called an **infinitesimal action of the Lie algebroid A** . Generalizing our previous results, parallel transport for a flat nonlinear connection is invariant under the appropriate notion of A -path-homotopy — see Problem 10.1.

This suggests proceeding as in the study case of nondegenerate Poisson structures. To that end, we introduce the **Poisson homotopy groupoid**

$$\Pi(M, \pi) := \frac{\text{cotangent paths}}{\text{cotangent path-homotopy}} \xrightarrow[\mathbf{s}]{\mathbf{t}} M$$

where the maps \mathbf{s} (for “source”) and \mathbf{t} (for “target”) give the initial and end points of the base path:

$$\begin{aligned} \mathbf{s} : \Pi(M, \pi) &\rightarrow M, & [a] &\mapsto \gamma_a(0), \\ \mathbf{t} : \Pi(M, \pi) &\rightarrow M, & [a] &\mapsto \gamma_a(1), \end{aligned}$$

and multiplication is defined by concatenation of cotangent paths:

$$[a] \circ [b] := [a \circ b] \quad \text{if} \quad \mathbf{s}([a]) = \mathbf{t}([b]).$$

We conclude the following:

Proposition 12.28. *The Poisson homotopy groupoid $\Pi(M, \pi)$ acts canonically on any complete symplectic realization $\mu : (S, \omega) \rightarrow (M, \pi)$:*

$$[a] \cdot p := \tau_a(p) \quad \text{if} \quad \mathbf{s}([a]) = \mu(p)$$

$\begin{array}{ccc} \Pi(M, \pi) & \curvearrowright & (S, \omega) \\ & \searrow & \downarrow \mu \\ & & (M, \pi) \end{array}$

It satisfies the following action-like properties:

- (i) *The constant cotangent path $a(t) \equiv 0_x$ acts as an identity:*

$$[0_x] \cdot p = p, \quad \forall p \in \mu^{-1}(x).$$

- (ii) *Whenever $[a], [b] \in \Pi(M, \pi)$ are composable one has*

$$([a] \circ [b]) \cdot p = [a] \cdot ([b] \cdot p).$$

12.7. Lagrangian fibrations

A surjective submersion $\mu : (S, \omega) \rightarrow M$ with *connected*, Lagrangian fibers is called a **regular Lagrangian fibration** over M . The basic facts about regular Lagrangian fibrations can be recast as part of the geometry of complete symplectic realizations of $(M, \pi \equiv 0)$. Since we will only consider submersions, we will omit the word *regular*.

We have already seen the following facts about Lagrangian fibrations:

- (i) Lagrangian fibrations $\mu : (S, \omega) \rightarrow M$ are the same as symplectic realizations of the zero Poisson structures, with connected fibers and $\dim S = 2 \dim M$.
- (ii) In particular, any such Lagrangian fibration comes with an infinitesimal action $\mathfrak{a} : \mu^*T^*M \rightarrow TS$ and $\text{Im } \mathfrak{a}_p = \text{Ker } d_p\mu$.
- (iii) Any integrable lattice $\Lambda \subset T^*M$ yields a *proper* Lagrangian fibration (see Example 6.5)

$$\mu : (\mathcal{T}_\Lambda = T^*M/\Lambda, \omega_\Lambda) \rightarrow M.$$

We now discuss a general proper Lagrangian fibration $\mu : (S, \omega) \rightarrow M$. Since μ is complete, by Proposition 12.10 the infinitesimal action integrates

to an action of the bundle of abelian groups T^*M on the fibers of μ :

$$\begin{array}{ccc}
 T^*M \curvearrowright (S, \omega) & & \\
 \searrow & \downarrow \mu & \\
 & (M, 0) &
 \end{array}
 \quad \xi \cdot p := \phi_{\alpha(-\xi)}^1(p)$$

In the language of the previous section, this is the action of the Poisson homotopy groupoid from Proposition 12.28.

Note that the action on each fiber is transitive. This follows because the fibers are connected and the action is infinitesimally transitive by (ii) above. Therefore, points in the same fiber $\mu^{-1}(x)$ share the same isotropy group

$$\Lambda_x := \{ \xi \in T_x^*M : \phi_{\alpha(\xi)}^1 = \text{Id}_{\mu^{-1}(x)} \}.$$

Since the action is locally free, Λ_x is a discrete subgroup. It is called the **subgroup of periods** of the Lagrangian fibration at x .

Proposition 12.29. *For any proper Lagrangian fibration $\mu : (S, \omega) \rightarrow (M, 0)$*

$$\Lambda := \bigcup_{x \in M} \Lambda_x \subset T^*M$$

is an integrable lattice.

Proof. We already know that the action of T_x^*M/Λ_x on $\mu^{-1}(x)$ is free and transitive. Since the fiber is compact, it follows that T_x^*M/Λ_x is compact, and so Λ_x is a lattice in T_x^*M .

It remains to prove that Λ is an integrable lattice, i.e., that it is locally the span of closed 1-forms. For that we need to show that for every $\xi_0 \in \Lambda_{x_0}$ there is some neighborhood U of x_0 and a closed 1-form $\alpha \in \Omega^1(U)$ such that $\alpha_x \in \Lambda_x$, for all $x \in U$. From the definition of Λ we see that α should be the solution of the equation

$$\phi_{\alpha(\alpha_x)}^1 = \text{Id} \quad \forall x \in U, \quad \alpha_{x_0} = \xi_0.$$

Let U be a neighborhood of x_0 where one has a local section of μ , i.e., a map $s : U \rightarrow S$, such that $\mu \circ s = \text{Id}$. The equation we want α to satisfy is equivalent to

$$(12.9) \quad \phi_{\alpha(\alpha_x)}^1(s(x)) = s(x), \quad \forall x \in U, \quad \alpha_{x_0} = \xi_0.$$

The left-hand side of this equation defines a map

$$F_s : T^*U \rightarrow \mu^{-1}(U), \quad F_s(\xi_x) := \phi_{\alpha(\xi_x)}^1(s(x)),$$

which satisfies $F_s(\xi_0) = s(x_0)$. We claim that F_s is a local diffeomorphism around ξ_0 . This follows because F_s is a bundle map, it covers the identity, and fiberwise it is a local diffeomorphism — since the action is infinitesimally

free. Hence, after shrinking U , there is a unique 1-form $\alpha \in \Omega^1(U)$ satisfying (12.9). This argument also shows that Λ is smooth.

Finally, we check that α is closed. Since $\phi_{a(\alpha)}^1 = \text{Id}$ and $\mu \circ \phi_{a(\alpha)}^t = \mu$,

$$\begin{aligned} 0 &= (\phi_{a(\alpha)}^1)^*\omega - \omega = \int_0^1 \frac{d}{dt}(\phi_{a(\alpha)}^t)^*\omega dt = \int_0^1 (\phi_{a(\alpha)}^t)^*\mathcal{L}_{a(\alpha)}\omega dt \\ &= \int_0^1 (\phi_{a(\alpha)}^t)^*di_{a(\alpha)}\omega dt = \int_0^1 (\phi_{a(\alpha)}^t)^*d(\mu^*\alpha) dt \\ &= \int_0^1 (\mu \circ \phi_{a(\alpha)}^t)^*d\alpha dt = \int_0^1 \mu^*d\alpha dt = \mu^*d\alpha. \end{aligned}$$

Since μ is a submersion, it follows that $d\alpha = 0$. □

In conclusion, any proper Lagrangian fibration $\mu : (S, \omega) \rightarrow M$ yields

- (i) an integrable lattice $\Lambda \subset T^*M$,
- (ii) a torus bundle $\mathcal{T}_\Lambda := T^*M/\Lambda$,
- (iii) a fiberwise free and transitive action

$$\begin{array}{ccc} \mathcal{T}_\Lambda \curvearrowright (S, \omega) & & \\ & \searrow \mu & \\ & & M \end{array} \quad [\xi] \cdot p := \phi_{a(-\xi)}^1(p)$$

In particular, each fiber of μ is diffeomorphic to a torus.

One should also expect the symplectic structures of \mathcal{T}_Λ and S to be related. In general, a section α of \mathcal{T}_Λ gives a diffeomorphism $\phi_{a(-\alpha)}^1 : S \rightarrow S$ which is *not* a symplectomorphism. Indeed, it would be too naive to expect that this action by sections is symplectic, since it ignores the symplectic structure of \mathcal{T}_Λ . Instead, the action of the torus bundle is symplectic in a sense that takes into account both symplectic structures:

Proposition 12.30. *The action of the torus bundle $(\mathcal{T}_\Lambda, \omega_\Lambda)$ on (S, ω) is symplectic in the sense that on $\mathcal{T}_\Lambda \times_M S$ one has*

$$(12.10) \quad \mathcal{A}^*\omega = \text{pr}_1^*\omega_\Lambda + \text{pr}_2^*\omega,$$

where the three maps denote the action and the two projections

$$\mathcal{A}, \text{pr}_2 : \mathcal{T}_\Lambda \times_M S \rightarrow S, \quad \text{pr}_1 : \mathcal{T}_\Lambda \times_M S \rightarrow \mathcal{T}_\Lambda.$$

In particular, the Lagrangian sections of \mathcal{T}_Λ act on S by symplectomorphisms.

Proof. For simplicity denote $\mathcal{T} := \mathcal{T}_\Lambda$. For the proof we interpret $\mathcal{T} \times_M S$ as a principal \mathcal{T} -bundle

$$\text{pr}_2 : P := \mathcal{T} \times_M S \rightarrow S,$$

where \mathcal{T} acts only the first factor. This action induces an infinitesimal action

$$\tilde{a} : \Omega^1(M) \rightarrow \mathfrak{X}(P), \quad \tilde{a}(\alpha) := (a_{\mathcal{T}}(\alpha), 0),$$

where $a_{\mathcal{T}}$ is the infinitesimal action for the torus bundle $\mu_{\mathcal{T}} : (\mathcal{T}, \omega_{\Lambda}) \rightarrow M$ — see Example 12.11. The result will follow by showing the following:

(i) The form

$$\Omega := \mathcal{A}^* \omega - \text{pr}_1^* \omega_{\Lambda} \in \Omega^2(P)$$

is basic; i.e., $\Omega = \text{pr}_2^* \eta$ for some $\eta \in \Omega^2(S)$.

(ii) One has $\eta = \omega$.

For (i), since Ω is closed — similar to the case of principal G -bundles — one checks that being basic is equivalent to being horizontal:

$$i_{\tilde{a}(\alpha)} \Omega = 0, \quad \forall \alpha \in \Omega^1(M).$$

To check this one observes the following:

- $\mathcal{A} : P \rightarrow S$ is \mathcal{T} -equivariant, so at the infinitesimal level, $\mathcal{A}_* \tilde{a} = a$.
- $\text{pr}_1 : P \rightarrow \mathcal{T}$ is also \mathcal{T} -equivariant and $(\text{pr}_1)_* \tilde{a} = a_{\mathcal{T}}$.
- By the definition of the infinitesimal action, $i_{a(\alpha)} \omega = \mu^* \alpha$.
- Similarly, for the torus bundle, $i_{a_{\mathcal{T}}(\alpha)} \omega_{\Lambda} = \mu_{\mathcal{T}}^* \alpha$.

Using these, one finds that

$$\begin{aligned} i_{\tilde{a}(\alpha)} \Omega &= \mathcal{A}^* i_{a(\alpha)} \omega - \text{pr}_1^* i_{a_{\mathcal{T}}(\alpha)} \omega_{\Lambda} \\ &= \mathcal{A}^* \mu^* \alpha - \text{pr}_1^* \mu_{\mathcal{T}}^* \alpha = 0, \end{aligned}$$

since $\mu \circ \mathcal{A} = \mu_{\mathcal{T}} \circ \text{pr}_1$. This shows that Ω is horizontal, so (i) holds.

To prove (ii), one pulls back $\Omega = \text{pr}_2^* \eta$ along sections of P of the type

$$\sigma_{\alpha} := (\bar{\alpha} \circ \mu, \text{id}_S) : S \rightarrow \mathcal{T} \times_M S \quad (\alpha \in \Omega^1(M)),$$

where $\bar{\alpha} : M \rightarrow \mathcal{T}$ denotes the section of \mathcal{T} induced by α . Observing that $\phi_{a(-\alpha)}^1 = \mathcal{A} \circ \sigma_{\alpha}$ and using the definition of ω_{Λ} one obtains

$$\begin{aligned} \eta &= \sigma_{\alpha}^* \mathcal{A}^* \omega - \sigma_{\alpha}^* \text{pr}_1^* \omega_{\Lambda} \\ &= (\phi_{a(-\alpha)}^1)^* \omega - (\bar{\alpha} \circ \mu)^* \omega_{\Lambda} \\ &= (\phi_{a(-\alpha)}^1)^* \omega - (\alpha \circ \mu)^* \omega_{\text{can}} \\ &= (\phi_{a(-\alpha)}^1)^* \omega + \mu^* d\alpha = \omega. \end{aligned}$$

For the last step we have used the identity at the end of the proof of Proposition 12.29 for $-\alpha$. □

Corollary 12.31. *Let $\mu : (S, \omega) \rightarrow M$ be a proper Lagrangian fibration. If it has a global Lagrangian section, then μ is isomorphic, as a symplectic realization, to $\mu_{\mathcal{T}_{\Lambda}} : (\mathcal{T}_{\Lambda}, \omega_{\Lambda}) \rightarrow M$. In particular, this always holds locally.*

Proof. Let $s : M \rightarrow S$ be a Lagrangian section. Consider the map

$$\Phi : \mathcal{T}_\Lambda \rightarrow S, \quad \Phi(\lambda_x) = \lambda_x \cdot s(x),$$

where the subscript x is the base point. We claim that Φ is an isomorphism of Lagrangian fibrations

$$\Phi^*\omega = \omega_\Lambda \quad \begin{array}{ccc} \mathcal{T}_\Lambda & \xrightarrow{\Phi} & S \\ & \searrow \mu_{\mathcal{T}_\Lambda} & \swarrow \mu \\ & M & \end{array}$$

Since Φ is built out of a free and proper action, it is a diffeomorphism. To see that it is a symplectomorphism we pull back (12.10) along the map $(\text{Id}, s \circ \mu_{\mathcal{T}_\Lambda}) : \mathcal{T}_\Lambda \rightarrow \mathcal{T}_\Lambda \times_M S$ to obtain

$$\Phi^*\omega = \omega_\Lambda + \mu_{\mathcal{T}_\Lambda}^* s^* \omega,$$

and then we use that s is Lagrangian. □

Remark 12.32 (Integral affine structures). Here we explain that integrable lattices are the same as *integral affine structures*. An integral affine atlas on a manifold M is an atlas for which the transition functions are restrictions of integral affine transformations, i.e., transformations of type

$$y^i = \sum_{j=1}^n A_j^i x^j + v^i, \quad A \in \text{GL}(n, \mathbb{Z}), v \in \mathbb{R}^n.$$

An **integral affine structure** on M is a maximal integral affine atlas.

Any integral affine structure on M gives an integrable lattice $\Lambda \subset T^*M$,

$$\Lambda_x := \{k_1 dx^1|_x + \dots + k_n dx^n|_x : k_i \in \mathbb{Z}\},$$

where (U, x^i) is any integral affine chart containing x . Since the transition functions are integral affine this is independent of the choice of chart.

Conversely, any integrable lattice Λ is locally spanned by closed 1-forms

$$\Lambda|_U = \{k_1 \alpha^1 + \dots + k_n \alpha^n : k_i \in \mathbb{Z}\}.$$

By shrinking U , we may assume that the forms are exact: $\alpha^i = dx^i$. Then (U, x^i) is a chart for M with the property that

$$\Lambda|_U = \{k_1 dx^1 + \dots + k_n dx^n : k_i \in \mathbb{Z}\}.$$

We call such a chart (U, x^i) an **integral affine chart** for Λ . The collection of such charts forms an integral affine atlas. Indeed, if (U, x^i) and (V, y^i) are two integral affine charts, then on the intersection we can write

$$dy^i = \sum_{j=1}^n A_j^i dx^j, \quad dx^i = \sum_{j=1}^n B_j^i dy^j,$$

for integer matrices $A = (A_j^i)$ and $B = (B_j^i)$ with $AB = BA = I$. This implies that the transition functions are integral affine transformations.

We obtain a 1-to-1 correspondence

$$\left\{ \begin{array}{l} \text{integral affine} \\ \text{structures on } M \end{array} \right\} \xleftrightarrow{\sim} \left\{ \begin{array}{l} \text{integrable lattices} \\ \Lambda \subset T^*M \end{array} \right\}.$$

We saw above that the base M of a proper Lagrangian fibration has a natural integral affine structure. These special coordinates are called in the theory of integrable systems **action coordinates**.

Fix an integral affine chart (U, x^i) for M and a local Lagrangian section $s : U \rightarrow S$. One has an induced a chart $(T^*U/\Lambda, x^i, \theta_i)$ for \mathcal{T}_Λ and a local isomorphism of Lagrangian fibrations

$$\Phi^*\omega = \sum_{i=1}^n dx^i \wedge d\theta_i \qquad \begin{array}{ccc} U \times \mathbb{T}^n & \xrightarrow{\Phi} & \mu^{-1}(U) \\ & \searrow \text{pr} & \swarrow \mu \\ & & U \end{array}$$

In the theory of integrable systems one calls the induced coordinates (x^i, θ_i) on S **action-angle coordinates**.

Exercise 12.33. Show that two action-angle charts on S are related by a transformation of the form

$$y^i = \sum_{j=1}^n A_j^i x^j + v^i, \quad \varphi_i = \sum_{j=1}^n B_i^j \theta_j + \frac{\partial f}{\partial y^i},$$

with $A \in \text{GL}(n, \mathbb{Z})$, $B = A^{-1} \in \text{GL}(n, \mathbb{Z})$, $v \in \mathbb{R}^n$, and f a smooth function.

One can use the previous result to classify proper Lagrangian fibrations over a fixed manifold, up to isomorphism. For that we need to understand how to “measure” the failure in having a Lagrangian section. Since these always exist locally, we start by comparing two local Lagrangian sections:

Lemma 12.34. *Let $\mu : (S, \omega) \rightarrow M$ be a proper Lagrangian fibration, and let $s_i : U_i \rightarrow S$, $i = 1, 2$, be two local Lagrangian sections. For $x \in U_1 \cap U_2$ set*

$$s_2(x) = \lambda_{12}(x) \cdot s_1(x), \quad \text{with } \lambda_{12}(x) \in \mathcal{T}_\Lambda.$$

Then λ_{12} is a local Lagrangian section of $(\mathcal{T}_\Lambda, \omega_\Lambda)$.

Proof. Since the \mathcal{T}_Λ -action is proper and free, λ_{12} is a well-defined smooth section of \mathcal{T}_Λ . Notice that $s_2 = \mathcal{A} \circ (\lambda_{12}, s_1)$, so pulling back (12.10) by

(λ_{12}, s_1) we find

$$s_2^*\omega = \lambda_{12}^*\omega_\Lambda + s_1^*\omega.$$

Since the s_i are Lagrangian, we must have $\lambda_{12}^*\omega_\Lambda = 0$. □

Let $\{U_i\}$ be an open cover of M such that for each open set there exists a Lagrangian section of the proper Lagrangian fibration $\mu : (S, \omega) \rightarrow M$. The previous lemma then gives Lagrangian sections on double intersections:

$$\lambda_{ij} : U_i \cap U_j \rightarrow \mathcal{T}_\Lambda.$$

Moreover, by the definition of the λ_{ij} , on a triple intersection $U_i \cap U_j \cap U_k$ we have

$$\lambda_{ik} \cdot s_i = s_k = \lambda_{jk} \cdot s_j = (\lambda_{ij} + \lambda_{jk}) \cdot s_i.$$

Since the action is free, we conclude that on a triple intersection

$$\lambda_{ij} + \lambda_{jk} - \lambda_{ik} = 0.$$

Therefore, denoting by $\underline{\mathcal{T}}_{\Lambda, \text{Lagr}}$ the sheaf of Lagrangian sections of the torus bundle $(\mathcal{T}_\Lambda, \omega_\Lambda)$, we introduce:

Definition 12.35. The **Lagrangian Chern class** of a proper Lagrangian fibration $\mu : (S, \omega) \rightarrow M$ is

$$c_1(S, \omega) = [\lambda_{ij}] \in H^1(M, \underline{\mathcal{T}}_{\Lambda, \text{Lagr}}).$$

One should show that this class is well-defined, i.e., independent of the choice of cover, which we leave as an exercise.

By construction, the Lagrangian Chern class expresses the obstruction for a proper Lagrangian fibration to admit a Lagrangian section. More importantly, as we mentioned before, we can use it to classify such fibrations up to isomorphism:

Theorem 12.36 (Duistermaat [60]). *For an integrable lattice $\Lambda \subset T^*M$, the Lagrangian Chern class induces a bijection between*

$$c_1 : \left\{ \begin{array}{l} \text{isomorphism classes of proper} \\ \text{Lagrangian fibrations inducing } \Lambda \end{array} \right\} \xrightarrow{\sim} H^1(M, \underline{\mathcal{T}}_{\Lambda, \text{Lagr}}).$$

The proof is similar to the standard construction of principal torus bundles out of transition functions. The fact that the transition functions take values in Lagrangian sections ensures that the result carries a symplectic structure locally modeled on ω_Λ .

Problems

12.1. Let $\mu : (S, \omega) \rightarrow (M, \pi)$ be a proper symplectic realization with oriented fibers. Show that the volume form on M obtained by integration of the Liouville volume form $\bigwedge^{\text{top}} \omega$ along the fibers of μ is invariant under Hamiltonian flows, so $\text{mod}(M, \pi) = 0$.

12.2. Consider a free and proper symplectic action of a Lie group G on a symplectic manifold (S, ω) . Consider $M = S/G$ with the induced Poisson structure π . Show that the quotient map $\mu : (S, \omega) \rightarrow (M, \pi)$ is a complete symplectic realization.

12.3. Let H be the Heisenberg Lie group

$$H = \left\{ \begin{pmatrix} 1 & a & b \\ 0 & 1 & c \\ 0 & 0 & 1 \end{pmatrix} : a, b, c \in \mathbb{R} \right\}.$$

Denote by \mathfrak{h} the Lie algebra of H , and let $\Lambda \subset H$ be the closed subgroup formed by matrices with integer entries. Show that one has a proper symplectic realization

$$\mu : (T^*(H/\Lambda), \omega_{\text{can}}) \rightarrow (\mathfrak{h}^*, \pi_{\mathfrak{h}}).$$

Conclude that duals of Lie algebras of noncompact type may have proper symplectic realizations.

NOTE: The homogeneous space H/Λ is an example of a nilmanifold.

12.4. A Poisson map $\Phi : (M, \pi_M) \rightarrow (N, \pi_N)$ is called **complete** if for any complete Hamiltonian vector field $X_H \in \mathfrak{X}(N)$, with $H \in C^\infty(M)$, the Hamiltonian vector field $X_{H \circ \Phi} \in \mathfrak{X}(M)$ is also complete.

- (a) A proper Poisson map $\Phi : (M, \pi_M) \rightarrow (N, \pi_N)$ is complete.
- (b) The image of a complete Poisson map $\Phi : (M, \pi_M) \rightarrow (N, \pi_N)$ is a union of symplectic leaves.

12.5. Let $\Phi : (M, \pi_M) \rightarrow (N, \pi_N)$ be a complete Poisson map. As for symplectic realizations, we define the *infinitesimal action* of T^*N on M :

$$\mathfrak{a} : \Phi^*T^*N \rightarrow TM, \quad \mathfrak{a}_x(\alpha) = \pi_{M,x}^\#((d_x\Phi)^*(\alpha)), \quad \alpha \in T_{\Phi(x)}^*N.$$

Show the following:

- (a) Given $x_0 \in M$ and any cotangent path $a : [0, 1] \rightarrow T^*N$ starting at $\Phi(x_0)$, there exists a path $\tilde{\gamma} : [0, 1] \rightarrow M$ such that $\Phi(\tilde{\gamma}(t)) = \gamma_a(t)$ and

$$\frac{d\tilde{\gamma}}{dt}(t) = \mathfrak{a}_{\tilde{\gamma}(t)}(a(t)), \quad \tilde{\gamma}(0) = x_0.$$

(b) One has a parallel transport map $\tau_a : \Phi^{-1}(\gamma_a(0)) \rightarrow \Phi^{-1}(\gamma_a(1))$ and cotangent path-homotopic paths induce the same parallel transport map.

12.6. Let $\mu : (S, \omega) \rightarrow (M, \pi)$ be a complete symplectic realization. Let $\mathcal{O} \subset S$ be the orbit of the infinitesimal action through $p \in S$. Recall that any path γ lying in \mathcal{O} is the unique lift of a cotangent path a_γ in (M, π) . Show that this defines a map

$$\Phi_* : \pi_1(\mathcal{O}, p) \rightarrow \Pi(M, \pi, \mu(p)), \quad [\gamma] \mapsto [a_\gamma],$$

which is an injective group homomorphism.

12.7. Let $\mu : (S, \omega) \rightarrow (M, \pi)$ be a symplectic realization. Show the following:

- (a) The fibers of μ are symplectic submanifolds if and only if (M, π) is a nondegenerate Poisson manifold.
- (b) If (M, π) is a nondegenerate Poisson manifold and the realization is complete, then parallel transport $\tau_\gamma : \mu^{-1}(\gamma(0)) \rightarrow \mu^{-1}(\gamma(1))$ along a path $\gamma : [0, 1] \rightarrow M$ is a symplectomorphism.

12.8. Let (M, ω_M) be a connected symplectic manifold. Assume one has a symplectic action of $\pi_1(M, x_0)$ on a symplectic manifold (F, ω_F) . Show that one obtains a complete symplectic realization

$$\mu : (\widetilde{M} \times_{\pi_1(M, x_0)} F, \text{pr}_M^* \omega_M + \text{pr}_F^* \omega_F) \rightarrow (M, \omega_M),$$

where \widetilde{M} is the universal covering space of M . Conversely, prove that any complete symplectic realization of (M, ω_M) is isomorphic to one of this type.

12.9. Let (θ, ω) be a cosymplectic structure on M (see Example 4.17).

- (a) Show that $\text{pr} : (S, \Omega) \rightarrow (\mathbb{S}^1, 0)$ is a symplectic realization, where $S = M \times \mathbb{S}^1$ and $\Omega = \omega + \theta \wedge d\varphi$.
- (b) Relate the orbits of the induced infinitesimal action to the Reeb vector field of (θ, ω) .
- (c) Give an example of a symplectic realization with compact total space for which the orbits of the infinitesimal action are noncompact.

12.10. Let (θ, ω) be a cosymplectic structure on M , and consider the corresponding Poisson structure π as in Example 4.17. Considering Ω as in the previous exercise, show that

$$\text{pr}_M : (M \times \mathbb{S}^1, \Omega) \rightarrow (M, \pi)$$

is a complete symplectic realization. Describe the orbits of the resulting infinitesimal action in terms of the geometry of (θ, ω) .

12.11. Consider a complete symplectic realization $\mu : (S, \omega) \rightarrow (M, \pi)$ of a regular Poisson manifold. Let $A'_x : \pi_2(S_x) \rightarrow \nu^*(S_x)$ be the variation of symplectic area map, and denote by \mathcal{N}_x its image — see Section 10.6.

- (a) Show that the infinitesimal action integrates to an action of the group $(\nu^*(S_x), +)$ on $\mu^{-1}(x)$.
- (b) Show that the abelian group \mathcal{N}_x acts trivially on $\mu^{-1}(x)$.
- (c) Deduce that \mathcal{N}_x is a discrete subgroup of $\nu^*(S_x)$.

12.12. Let $\mu : (S, \omega) \rightarrow (M, \pi)$ be a symplectic realization. Show that the following are equivalent:

- (a) The fibers of μ are isotropic submanifolds.
- (b) (M, π) is regular with rank $\pi = 2 \dim M - \dim S$.

12.13. Let $\mu : (S, \omega) \rightarrow (M, \pi)$ be a proper symplectic realization with connected isotropic fibers, so (M, π) is regular (see the previous problem). Let

$$\Lambda_x := \{\xi \in \nu_x^*(\mathcal{F}_\pi) : \phi_{\alpha(\xi)}^1 = \text{Id}_{\mu^{-1}(x)}\}.$$

- (a) Show that Λ_x is a lattice in $\nu_x^*(\mathcal{F}_\pi)$.
- (b) Show that $\Lambda := \bigcup_{x \in M} \Lambda_x$ is locally generated by closed 1-forms whose restriction to the symplectic leaves vanishes.
- (c) If \mathcal{F}_π is the foliation by the fibers of a submersion $q : M \rightarrow B$, show that $\Lambda = q^* \Lambda_0$, where $\Lambda_0 \subset T^*B$ is an integrable lattice.

NOTE: One calls $\Lambda \subset \nu^*(\mathcal{F}_\pi)$ a transverse integrable lattice. It defines a **transverse integral affine structure** on the foliated manifold (M, \mathcal{F}_π) .

12.14. Classify up to isomorphism all proper Lagrangian fibrations over a circle: $\mu : (S, \omega) \rightarrow \mathbb{S}^1$.

A Crash Course on Lie Groupoids

In this chapter we give an overview of Lie groupoids. We recommend [45, 123] for more details and proofs.

13.1. Lie groupoids

Definition 13.1. A **groupoid** consists of a set M (“objects”), a set \mathcal{G} (“arrows”) together with the following structure maps:

- (i) **source** $\mathbf{s} : \mathcal{G} \rightarrow M$ and **target** $\mathbf{t} : \mathcal{G} \rightarrow M$,
- (ii) **multiplication** $\mathbf{m} : \mathcal{G}^{(2)} \rightarrow \mathcal{G}$, $(g, h) \mapsto \mathbf{m}(g, h) =: g \cdot h$,
defined on the set of composable arrows

$$\mathcal{G}^{(2)} := \{(g, h) \in \mathcal{G} \times \mathcal{G} : \mathbf{s}(g) = \mathbf{t}(h)\}$$

and which satisfies

- $\mathbf{s}(g \cdot h) = \mathbf{s}(h)$ and $\mathbf{t}(g \cdot h) = \mathbf{t}(g)$,
- $(g \cdot h) \cdot k = g \cdot (h \cdot k)$,
- (iii) **unit map** $\mathbf{u} : M \rightarrow \mathcal{G}$, $x \mapsto \mathbf{u}(x) =: 1_x$, which satisfies
 - $\mathbf{s}(1_x) = \mathbf{t}(1_x) = x$,
 - $g \cdot 1_{\mathbf{s}(g)} = 1_{\mathbf{t}(g)} \cdot g = g$,
- (iv) **inverse map** $\boldsymbol{\iota} : \mathcal{G} \rightarrow \mathcal{G}$, $g \mapsto \boldsymbol{\iota}(g) =: g^{-1}$, which satisfies
 - $\mathbf{s}(g^{-1}) = \mathbf{t}(g)$ and $\mathbf{t}(g^{-1}) = \mathbf{s}(g)$,
 - $g^{-1} \cdot g = 1_{\mathbf{s}(g)}$ and $g \cdot g^{-1} = 1_{\mathbf{t}(g)}$.

Sometimes one abbreviates all this by saying that \mathcal{G} is a small category, with space of objects M , for which every arrow has an inverse.

For $g \in \mathcal{G}$ we write $g : x \rightarrow y$ to indicate that $\mathbf{s}(g) = x$, $\mathbf{t}(g) = y$ and we also picture it as

$$y \xleftarrow{g} x.$$

We will often represent such a groupoid by the symbols

$$\mathcal{G} \rightrightarrows M,$$

and we will say that \mathcal{G} is a groupoid over M . We are interested in the smooth version of groupoids:

Definition 13.2. A **Lie groupoid** is a groupoid $\mathcal{G} \rightrightarrows M$ where \mathcal{G} and M are manifolds and

- (i) \mathbf{s}, \mathbf{t} are submersions,
- (ii) \mathbf{m}, \mathbf{u} , and ι are smooth maps.

Remark 13.3. Eventually, we will have to consider Lie groupoids with a non-Hausdorff space of arrows. For now, the reader may safely assume that all manifolds are Hausdorff. The precise assumptions that we will make ensure that all the proofs actually also work in the non-Hausdorff setting. All this will be explained in detail and motivated in Section 13.7.

Note that since \mathbf{s} and \mathbf{t} are submersions, the set of composable arrows $\mathcal{G}^{(2)}$ is a smooth submanifold of $\mathcal{G} \times \mathcal{G}$, and so it makes sense to ask that $\mathbf{m} : \mathcal{G}^{(2)} \rightarrow \mathcal{G}$ is smooth.

Exercise 13.4. Show that for a Lie groupoid $\mathcal{G} \rightrightarrows M$ the multiplication \mathbf{m} is a submersion, the unit \mathbf{u} is a closed embedding, and the inverse ι is a diffeomorphism.

Given a (Lie) groupoid $\mathcal{G} \rightrightarrows M$ one defines the following:

- The **s-fiber** and the **t-fiber** above a point $x \in M$:

$$\mathbf{s}^{-1}(x) = \{g \in \mathcal{G} : \mathbf{s}(g) = x\},$$

$$\mathbf{t}^{-1}(x) = \{g \in \mathcal{G} : \mathbf{t}(g) = x\}.$$

These are submanifolds of \mathcal{G} .

- The **right translation** R_g and the **left translation** L_g by an arrow $g : x \rightarrow y$:

$$R_g : \mathbf{s}^{-1}(y) \rightarrow \mathbf{s}^{-1}(x), \quad R_g(h) := h \cdot g,$$

$$L_g : \mathbf{t}^{-1}(x) \rightarrow \mathbf{t}^{-1}(y), \quad L_g(h) := g \cdot h.$$

They are diffeomorphisms with inverses $R_{g^{-1}}$ and $L_{g^{-1}}$.

- The **isotropy group** of \mathcal{G} at $x \in M$:

$$\mathcal{G}_x := \mathbf{s}^{-1}(x) \cap \mathbf{t}^{-1}(x) = \{g \in \mathcal{G} : \mathbf{s}(g) = \mathbf{t}(g) = x\}.$$

The multiplication of \mathcal{G} gives rise to a group structure on \mathcal{G}_x . Moreover, \mathcal{G}_x is a submanifold of \mathcal{G} and becomes a Lie group.

- The **orbit of \mathcal{G} through $x \in M$** :

$$\mathcal{O}_x := \mathbf{t}(\mathbf{s}^{-1}(x)) = \{y \in M : \exists g : x \rightarrow y \text{ in } \mathcal{G}\},$$

which is an immersed submanifold of M .

The multiplication of \mathcal{G} yields a free and proper right action of the isotropy group on the \mathbf{s} -fiber

$$(13.1) \quad \mathbf{s}^{-1}(x) \times \mathcal{G}_x \rightarrow \mathbf{s}^{-1}(x), \quad (g, h) \mapsto g \cdot h,$$

and \mathcal{O}_x is identified with the resulting quotient,

$$\begin{array}{ccc} & \mathbf{s}^{-1}(x) \circlearrowleft \mathcal{G}_x & \\ \text{proj} \swarrow & \downarrow \mathbf{t} & \\ \mathbf{s}^{-1}(x) / \mathcal{G}_x & \xrightarrow{\sim} & \mathcal{O}_x \end{array}$$

The smooth structure on \mathcal{O}_x is defined as the unique one that makes $\mathbf{t} : \mathbf{s}^{-1}(x) \rightarrow \mathcal{O}_x$ into a submersion. With this, \mathcal{O}_x becomes an immersed submanifold of M which, in general, fails to be embedded. The orbits form a partition of M called the **orbit foliation** of the Lie groupoid $\mathcal{G} \rightrightarrows M$.

Exercise 13.5. Show that, for any $x, y \in M$ in the same orbit of \mathcal{G} , the Lie groups \mathcal{G}_x and \mathcal{G}_y are isomorphic.

There is a natural notion of morphism between groupoids. The smooth version is as follows:

Definition 13.6. A **Lie groupoid morphism** from $\mathcal{G} \rightrightarrows M$ to $\mathcal{H} \rightrightarrows N$ is a pair of smooth maps commuting with sources and targets

$$\begin{array}{ccc} \mathcal{G} & \xrightarrow{\Phi} & \mathcal{H} \\ \mathbf{t} \downarrow \downarrow \mathbf{s} & & \mathbf{t} \downarrow \downarrow \mathbf{s} \\ M & \xrightarrow{\varphi} & N \end{array}$$

and compatible with multiplications

$$\Phi(g \cdot h) = \Phi(g) \cdot \Phi(h), \quad \forall (g, h) \in \mathcal{G}^{(2)}.$$

It is easy to check how a Lie groupoid morphism interacts with the various structures present in groupoids. For example, such a morphism

$\Phi : \mathcal{G} \rightarrow \mathcal{H}$ induces the following:

- (i) smooth maps between the source fibers $\mathbf{s}^{-1}(x) \rightarrow \mathbf{s}^{-1}(\varphi(x))$ and between the target fibers $\mathbf{t}^{-1}(x) \rightarrow \mathbf{t}^{-1}(\varphi(x))$,
- (ii) a morphism of Lie groups between isotropy Lie groups $\mathcal{G}_x \rightarrow \mathcal{H}_{\varphi(x)}$,
- (iii) a smooth map between orbits $\mathcal{O}_x \rightarrow \mathcal{O}_{\varphi(x)}$.

By a **Lie subgroupoid** of a Lie groupoid $\mathcal{G} \rightrightarrows M$ we mean a Lie groupoid $\mathcal{H} \rightrightarrows N$ together with a Lie groupoid morphism $i : \mathcal{H} \rightarrow \mathcal{G}$ which is an injective immersion.

Note that groupoids need not have connected space of units or space of arrows. We will need to make some connectedness assumptions at various places. As we will see, these are usually assumptions on the \mathbf{t} -fibers — or, equivalently, on the \mathbf{s} -fibers since inversion gives a diffeomorphism between them. An example of this is the following:

Proposition 13.7. *Let $\mathcal{G} \rightrightarrows M$ be a Lie groupoid with connected \mathbf{t} -fibers. Then any open set $U \subset \mathcal{G}$ containing the units generate \mathcal{G} ; i.e., any $g \in \mathcal{G}$ can be factored as a product of elements of U :*

$$g = u_1 \cdots u_n \quad (u_i \in U).$$

Proof. We will show that for any $x \in M$ the set

$$S = \{g \in \mathbf{t}^{-1}(x) \mid g \text{ can be written as a product of elements in } U\}$$

is both open and closed in $\mathbf{t}^{-1}(x)$. By \mathbf{t} -connectedness, it is the entire target fiber and the result follows.

Since left-translations are diffeomorphisms between the fibers, this set is clearly open in $\mathbf{t}^{-1}(x)$. We claim that the complement of S in $\mathbf{t}^{-1}(x)$ is also open. For that let $g \notin S$ with $\mathbf{t}(g) = x$. Since left-translations and inversion are diffeomorphisms, the set

$$gU^{-1} := \{gu^{-1} : \mathbf{s}(u) = \mathbf{s}(g), u \in U\}$$

is a neighborhood of g in $\mathbf{t}^{-1}(x)$ which does not intersect S : if $gu^{-1} \in S$, then $g = u_1 \cdots u_n \cdot u \in S$, contradicting $g \notin S$. □

13.2. Lie groupoids: Examples and basic constructions

Example 13.8 (Lie groups). Lie groups are the same thing as Lie groupoids over a point:

$$\begin{array}{c} \mathcal{G} \\ \mathbf{t} \downarrow \downarrow \mathbf{s} \\ \{\text{pt}\} \end{array}$$



Example 13.9 (Bundles of Lie groups). Bundles of Lie groups are the same thing as Lie groupoids where the source and the target coincide:

$$\begin{array}{c} \mathcal{G} \\ \mathbf{t} \downarrow \mathbf{s} \\ M \end{array} \quad \img alt="fish icon" data-bbox="825 215 859 234"/>$$

Example 13.10 (Pair groupoids). For a manifold M , one has its pair groupoid

$$\begin{array}{c} M \times M \\ \text{pr}_1 \downarrow \downarrow \text{pr}_2 \\ M \end{array} \quad \left(\begin{array}{c} \text{arrows:} \\ y \xleftarrow{(y,x)} x \end{array} \right)$$

with source $\mathbf{s}(y, x) = \text{pr}_2(y, x) = x$ and $\mathbf{t}(y, x) = \text{pr}_1(y, x) = y$. This groupoid has precisely one arrow between any two points, so multiplication is given by

$$(z, y) \cdot (y, x) = (z, x) \quad \left(z \xleftarrow{(z,y)} y \xleftarrow{(y,x)} x \right)$$

and the units and inverses are $1_x = (x, x)$ and $(x, y)^{-1} = (y, x)$. Note that the isotropy groups are trivial and that there is one single orbit. 

Example 13.11 (Submersion groupoids). Given a submersion $\mu : M \rightarrow N$, one has the Lie subgroupoid $M \times_\mu M \rightrightarrows M$ of the pair groupoid $M \times M \rightrightarrows M$ consisting of arrows (y, x) such that $\mu(y) = \mu(x)$:

$$\begin{array}{c} M \times_\mu M \\ \text{pr}_1 \downarrow \downarrow \text{pr}_2 \\ M \end{array} \quad \left(\begin{array}{c} \text{arrows: if } \mu(y) = \mu(x), \\ y \xleftarrow{(y,x)} x \end{array} \right)$$

This groupoid has precisely one arrow between any two points lying in the same fiber of μ . Note that the isotropy groups are still trivial but now the orbits are the fibers on μ . When $\mu : M \rightarrow M$ is the identity map, the corresponding submersion groupoid is called the *identity groupoid* of M and is often denoted by $M \rightrightarrows M$. 

Example 13.12 (The homotopy groupoid of a manifold). For any manifold M , we have its homotopy groupoid, mentioned in the previous chapter,

$$\begin{array}{c} \Pi(M) \\ \mathbf{t} \downarrow \downarrow \mathbf{s} \\ M \end{array} \quad \left(\begin{array}{c} \text{arrows:} \\ \gamma(1) \xleftarrow{[\gamma]} \gamma(0) \end{array} \right)$$

The multiplication is induced by concatenation, where one needs to reparameterize paths in order to ensure smoothness. Note the following:

- (i) The orbits are the connected components of M .
- (ii) The isotropy group at x is the fundamental group $\pi_1(M, x)$.

Also, the principal $\pi_1(M, x)$ -bundle

$$\mathbf{t} : \mathbf{s}^{-1}(x) \rightarrow M$$

is the universal cover of M , in one of its standard realizations. The smooth structure of $\Pi(M)$ will be discussed below. 

Example 13.13 (Action groupoids). Any Lie group action on a manifold

$$G \times M \rightarrow M, \quad (g, x) \mapsto gx$$

gives rise to the so-called action groupoid $G \times M \rightrightarrows M$. It is the groupoid

$$G \times M \begin{array}{c} \mathbf{t} \downarrow \downarrow \mathbf{s} \\ \downarrow \\ M \end{array} \left(\begin{array}{c} \text{arrows:} \\ \xleftarrow{(g,x)} \\ gx \longleftarrow x \end{array} \right)$$

with source map $\mathbf{s}(g, x) = x$, target map $\mathbf{t}(g, x) = gx$, and multiplication

$$(g, x) \cdot (h, y) = (gh, y) \quad \left(\begin{array}{c} \xleftarrow{(gh,y)} \\ \xleftarrow{(g,x)} \quad \xleftarrow{(h,y)} \\ gx \longleftarrow x \longleftarrow y \\ \parallel \qquad \qquad \parallel \\ ghx \qquad \qquad \quad hy \end{array} \right)$$

For this groupoid we have the following:

- (i) Each \mathbf{s} -fiber is diffeomorphic to G .
- (ii) The isotropy group at x is the isotropy group of the action

$$G_x = \{g \in G : gx = x\}.$$

- (iii) The orbit through x coincides with the orbit of the action

$$\mathcal{O}_x = \{gx : g \in G\}. \quad \img alt="fish icon" data-bbox="825 715 855 735"/>$$

Example 13.14 (Flow of a vector field). Any vector field $X \in \mathfrak{X}(M)$ gives rise to a flow ϕ_X^t which is defined on an open $\mathcal{D}(X) \subset \mathbb{R} \times M$, so that we have a smooth map

$$\phi_X : \mathcal{D}(X) \rightarrow M, \quad (t, x) \mapsto \phi_X^t(x).$$

This gives rise to a Lie groupoid

$$\mathcal{D}(X) \begin{array}{c} \mathbf{t} \downarrow \downarrow \mathbf{s} \\ \downarrow \\ M \end{array} \left(\begin{array}{c} \text{arrows:} \\ \xleftarrow{(t,x)} \\ \phi_X^t(x) \longleftarrow x \end{array} \right)$$

with source map $\mathbf{s}(t, x) = x$, target map $\mathbf{t}(t, x) = \phi_X^t(x)$, and multiplication

$$(t, x) \cdot (s, y) = (t + s, y) \quad \left(\begin{array}{ccc} & \xrightarrow{(t+s, y)} & \\ \swarrow & & \searrow \\ \phi_X^t(x) & \xleftarrow{(t, x)} x & \xleftarrow{(s, y)} y \\ \parallel & & \parallel \\ \phi_X^{t+s}(y) & & \phi_X^s(y) \end{array} \right)$$

One finds the following:

- (i) The orbits are precisely the images of the integral curves.
- (ii) When X is complete, one has $\mathcal{D}(X) = \mathbb{R} \times M$, ϕ_X defines an action of \mathbb{R} on M , and we recover the action groupoid $\mathbb{R} \ltimes M$.

Example 13.15 (Gauge groupoid). Any principal G -bundle over M

$$\begin{array}{c} P \circlearrowleft G \\ \text{pr} \downarrow \\ M \end{array}$$

gives rise to a Lie groupoid $\text{Gauge}_G(P) \rightrightarrows M$ called the gauge groupoid of P . It is simply the quotient of the pair groupoid $P \times P \rightrightarrows P$, modulo the diagonal action of G :

$$(q, p) \cdot g := (qg, pg).$$

Denoting by $[q, p] \in (P \times P)/G$ the class of (q, p) , the gauge groupoid $\text{Gauge}_G(P) \rightrightarrows M$ is then

$$\begin{array}{c} (P \times P)/G \\ \mathbf{t} \downarrow \downarrow \mathbf{s} \\ M \end{array} \quad \left(\begin{array}{c} \text{arrows:} \\ \text{pr}(q) \xleftarrow{[q, p]} \text{pr}(p) \end{array} \right)$$

It is a good exercise to write down the multiplication. Also, note the following:

- (i) Each isotropy group is isomorphic to G (but not canonically!).
- (ii) One has a single orbit.

A groupoid $\mathcal{G} \rightrightarrows M$ is called **transitive** if it has only one orbit, i.e., if any two points $x, y \in M$ are connected by at least one arrow. Any such groupoid is actually isomorphic to a gauge groupoid of a principal bundle. However, to realize such an isomorphism, one has to make a choice of a base point $x \in M$, as shown by the following exercise.

Exercise 13.16. Let $\mathcal{G} \rightrightarrows M$ be a transitive groupoid, and let $x \in M$. Prove that \mathcal{G} is isomorphic to $\text{Gauge}_{\mathcal{G}_x}(P_x)$, where $P_x = \mathbf{s}^{-1}(x)$ is the source fiber viewed as a principal \mathcal{G}_x -bundle.

Here is an interesting particular case: let \widetilde{M} be the universal covering space of the manifold M . The action of the fundamental group $G = \pi_1(M)$ on \widetilde{M} by deck transformations is a principal action, when we view $\pi_1(M)$ as a discrete group

$$\begin{array}{c} \widetilde{M} \circlearrowleft \pi_1(M) \\ \text{pr} \downarrow \\ M \end{array}$$

We leave it as an exercise to check that the associated gauge groupoid is isomorphic to the fundamental groupoid $\Pi(M)$ of M . It follows in particular that $\Pi(M)$ has a smooth structure so that it becomes a Lie groupoid. 

Example 13.17 (Restrictions). Any set-theoretical (not yet Lie) groupoid $\mathcal{G} \rightrightarrows M$ can be restricted to any subset $N \subset M$ to obtain a groupoid over N , with space of arrows

$$\mathcal{G}|_N := \{g \in \mathcal{G} : \mathbf{s}(g), \mathbf{t}(g) \in N\}.$$

If \mathcal{G} is a Lie groupoid and $N \subset M$ is a submanifold, the restriction $\mathcal{G}|_N \rightrightarrows N$, in general, will not be a Lie groupoid: one needs conditions on N to ensure that $\mathcal{G}|_N$ is smooth. One instance when this works is when $N = \mathcal{O}$ is an orbit of \mathcal{G} . In this case, the resulting restriction $\mathcal{G}|_{\mathcal{O}}$ is a transitive groupoid. The corresponding principal bundle is, of course, the \mathbf{s} -fiber above any point $x \in \mathcal{O}$. 

Example 13.18 (Pullbacks). Restrictions are particular cases of pullbacks arising from inclusions $N \hookrightarrow M$. In general, one can pull back a groupoid $\mathcal{G} \rightrightarrows M$ along any map

$$\varphi : N \rightarrow M,$$

resulting in a groupoid over N :

$$\varphi^! \mathcal{G} := N \times_M \mathcal{G} \times_M N := \{ (y, g, x) \in N \times \mathcal{G} \times N : \varphi(y) \xleftarrow{g} \varphi(x) \},$$

$$\begin{array}{ccc} \varphi^! \mathcal{G} & & \\ \mathbf{t} \downarrow \parallel \mathbf{s} & & \\ N & & \end{array} \quad (y \xleftarrow{(y,g,x)} x)$$

In the smooth context, when \mathcal{G} is a Lie groupoid and φ is a smooth map, the smoothness of $\varphi^! \mathcal{G}$ as a submanifold of the product $N \times \mathcal{G} \times N$ is not ensured. But if this happens, then $\varphi^! \mathcal{G} \rightrightarrows N$ is a Lie groupoid, called the

pullback Lie groupoid, and we have a Lie groupoid morphism

$$\begin{array}{ccc}
 \varphi^! \mathcal{G} & \xrightarrow{\Phi} & \mathcal{G} \\
 \begin{array}{c} \downarrow \text{t} \\ \downarrow \text{s} \end{array} & & \begin{array}{c} \downarrow \text{t} \\ \downarrow \text{s} \end{array} \\
 N & \xrightarrow{\varphi} & M
 \end{array} \quad (y, g, x) \longmapsto g.$$

Exercise 13.19. Show that if φ is a submersion, then $\varphi^! \mathcal{G} \subset N \times \mathcal{G} \times N$ is a submanifold and that, with this smooth structure, it becomes a Lie groupoid over N . 

Example 13.20 (The groupoid of a cover). Another interesting instance of the pullback construction appears as follows. Let $\mathcal{U} = \{U_i : i \in I\}$ be a countable open cover of a manifold M and consider the *disjoint union*

$$N := \bigsqcup_{i \in I} U_i,$$

with the obvious map $\varphi : N \rightarrow M$. If $\mathcal{G} = (M \rightrightarrows M)$ is the identity groupoid of M , the pullback groupoid $\varphi^! \mathcal{G}$ is called the groupoid of the cover and is denoted $\mathcal{G}_{\mathcal{U}} \rightrightarrows N$:

$$\begin{array}{ccc}
 \mathcal{G}_{\mathcal{U}} = \bigsqcup_{i,j} U_i \cap U_j & = \{(i, x, j) : i, j \in I, x \in U_i \cap U_j\} & \begin{array}{c} (i, x, j) \\ \swarrow \text{t} \quad \searrow \text{s} \\ (i, x) \quad (j, x) \end{array} \\
 \begin{array}{c} \downarrow \text{t} \\ \downarrow \text{s} \end{array} & & \\
 \bigsqcup_{i \in I} U_i & = \{(i, x) : i \in I, x \in U_i\} & \end{array}$$

Example 13.21 (Tangent Lie groupoid). For any Lie groupoid $\mathcal{G} \rightrightarrows M$, passing to tangent spaces and taking the differentials of all the structure maps of \mathcal{G} , one obtains a new groupoid

$$T\mathcal{G} \rightrightarrows TM,$$

called the tangent groupoid of \mathcal{G} .

For instance, when $\mathcal{G} = G$ is a Lie group — so M is a point — $T\mathcal{G}$ is again a Lie group which is canonically isomorphic to the semidirect product $G \ltimes \mathfrak{g}$ associated to the adjoint action of G on \mathfrak{g} . For general Lie groupoids, while there is no analogue of adjoint action and representation, $T\mathcal{G}$ may be seen as a possible replacement.

One can form the direct sum of the tangent groupoid with itself, obtaining a groupoid

$$\bigoplus^2 T\mathcal{G} := T\mathcal{G} \oplus_{\mathcal{G}} T\mathcal{G} \rightrightarrows \bigoplus^2 TM := TM \oplus_M TM,$$

with source, target, and unit given by

$$\begin{aligned} \bigoplus^2 ds(u, v) &:= (ds(u), ds(v)), & \bigoplus^2 dt(u, v) &:= (dt(u), dt(v)), \\ \bigoplus^2 du(w_1, w_2) &:= (du(w_1), du(w_2)) \end{aligned}$$

and multiplication defined by

$$\bigoplus^2 dm((u_1, v_1), (u_2, v_2)) := (dm(u_1, u_2), dm(v_1, v_2)).$$

This construction extends to any number of factors, producing Lie groupoids $\bigoplus^k TG \rightrightarrows \bigoplus^k TM$.

There is also a cotangent groupoid $T^*\mathcal{G}$, but this notion is a bit more subtle and it will be discussed after introducing the Lie algebroid of a Lie groupoid, at the end of Section 13.5. 

Example 13.22 (General linear groupoid). The same way that any finite-dimensional vector space V gives rise to a Lie group

$$GL(V) := \{A : V \rightarrow V : A = \text{linear isomorphism}\},$$

a vector bundle $E \rightarrow M$ gives rise to a Lie groupoid over M :

$$\begin{array}{c} GL(E) := \{(y, A, x) : x, y \in M, A : E_x \rightarrow E_y \text{ linear isomorphism}\} \\ \begin{array}{c} \mathfrak{t} \downarrow \\ \downarrow s \\ M \end{array} \end{array}$$

The reader should be able to figure out easily all the structure maps. When M is a point and $E = V$ is a vector space we recover the Lie group $GL(V)$. In general, one has the isotropy groups

$$GL(E)_x = GL(E_x).$$

Moreover, $GL(E) \rightrightarrows M$ is a transitive groupoid and so it comes from a principal bundle. In this case there is a canonical choice for the principal bundle, namely the frame bundle of E :

$$Fr(E) = \{(x, u) : x \in M, u : \mathbb{R}^n \rightarrow E_x \text{ linear isomorphism}\}.$$

Note that a linear isomorphism $u : \mathbb{R}^n \rightarrow E_x$ is the same as a frame, i.e., a basis (u_1, \dots, u_n) in the fiber E_x . It is a right principal GL_n -bundle, where $A \in GL_n$ acts on frame u by precomposition: $uA := u \circ A$.

Exercise 13.23. Show that, indeed, there is an isomorphism of Lie groupoids

$$GL(E) \cong \text{Gauge}_{GL_n}(Fr(E)). \quad \img alt="fish icon" data-bbox="825 895 855 910"/>$$

Example 13.24 (Actions of Lie groupoids). Similarly to actions of groups, one has actions of groupoids and the associated action groupoids. Given a groupoid $\mathcal{G} \rightrightarrows M$, to make sense of an action on a set S we need a map

$$\mu : S \rightarrow M$$

along which the action takes place. The action by an arrow $g : x \rightarrow y$ is now a map

$$\mu^{-1}(x) \rightarrow \mu^{-1}(y), \quad p \mapsto g \cdot p,$$

and the usual axioms of an action must be satisfied:

- (i) $1_{\mu(p)} \cdot p = p$.
- (ii) $g \cdot (h \cdot p) = (g \cdot h) \cdot p$ for $(g, h) \in \mathcal{G}^{(2)}$.

In order to talk about smoothness of the action of a Lie groupoid $\mathcal{G} \rightrightarrows M$ on a smooth map $\mu : S \rightarrow M$ we reformulate the definition as follows. We first form the fiber product

$$\mathcal{G} \times_M S := \{(g, p) \in \mathcal{G} \times S : \mathbf{s}(g) = \mu(p)\} \subset \mathcal{G} \times S.$$

Since \mathbf{s} is a submersion, this is a smooth submanifold of $\mathcal{G} \times S$. Then we can define an **action of the Lie groupoid $\mathcal{G} \rightrightarrows M$ on $\mu : S \rightarrow M$** , pictured as

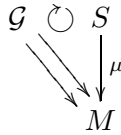

to be a smooth map

$$\mathcal{A} : \mathcal{G} \times_M S \rightarrow S, \quad (g, p) \mapsto g \cdot p,$$

such that $\mu(g \cdot p) = \mathbf{t}(g)$, and (i) and (ii) hold. Notice that, in particular, one obtains for each $x \in M$ a Lie group action of the isotropy group \mathcal{G}_x on the fiber over x :

$$\mathcal{G}_x \times \mu^{-1}(x) \rightarrow \mu^{-1}(x).$$

Exercise 13.25. Given an action of a Lie groupoid $\mathcal{G} \rightrightarrows M$ on a map $\mu : S \rightarrow M$ define the action groupoid $\mathcal{G} \times S \rightrightarrows S$. What are its orbits and its isotropy groups? Check that the restriction of $\mathcal{G} \times S \rightrightarrows S$ to each fiber $\mu^{-1}(x)$ is isomorphic to the action groupoid $\mathcal{G}_x \times \mu^{-1}(x) \rightrightarrows \mu^{-1}(x)$.

Remark 13.26. Looking back at the case studies of symplectic realizations in the previous chapter, one notices the following:

- For a proper Lagrangian fibration $\mu : (S, \omega) \rightarrow M$, we have an action of the bundle of Lie groups $\mathcal{T}_\Lambda \rightrightarrows M$ on $\mu : S \rightarrow M$.
- For a complete symplectic realization $\mu : (S, \omega) \rightarrow (M, \pi)$ of a non-degenerate Poisson structure, we found an action of the homotopy groupoid $\Pi(M) \rightrightarrows M$ on $\mu : S \rightarrow M$.

Also, several of the examples of groupoids we have seen before come with natural actions:

- For a vector bundle $\text{pr} : E \rightarrow M$, the groupoid $\text{GL}(E) \rightrightarrows M$ from Example 13.22 acts on $\text{pr} : E \rightarrow M$.
- The gauge groupoid $\text{Gauge}_G(P)$ of a principal bundle from Example 13.15 acts on $\text{pr} : P \rightarrow M$. 

Example 13.27 (Homotopy and holonomy groupoids of a foliation). Recall that a foliation \mathcal{F} of M is a partition of M into leaves — see Section C.1 — so it can be identified with an equivalence relation

$$(13.2) \quad \text{Rel}(\mathcal{F}) \subset M \times M$$

consisting of the pairs (x, y) where x and y belong to the same leaf. Set theoretically, this is a subgroupoid of the pair groupoid $M \times M$:

$$\begin{array}{ccc} \text{Rel}(\mathcal{F}) & \hookrightarrow & M \times M \\ & \searrow & \downarrow \text{t} \downarrow \text{s} \\ & & M \end{array}$$

Its orbits are precisely the leaves of \mathcal{F} . In general, this is not a Lie subgroupoid. However, there are several “desingularizations” obtained by looking at paths in the leaves connecting two points and imposing some equivalence relation on those paths. One can show that any “desingularization” lies in between the *holonomy groupoid* (smallest “desingularization”) and the *homotopy groupoid* (largest “desingularization”):

$$\begin{array}{ccccccc} \Pi(M, \mathcal{F}) & \longrightarrow & \mathcal{G} & \longrightarrow & \text{Hol}(M, \mathcal{F}) & \dashrightarrow & \text{Rel}(\mathcal{F}) \\ & \searrow & \downarrow & \swarrow & \swarrow & \searrow & \\ & & M & & & & \end{array}$$

Let us start by discussing the **homotopy groupoid** $\Pi(M, \mathcal{F}) \rightrightarrows M$. It consists of leafwise path-homotopy classes

$$\Pi(M, \mathcal{F}) := \frac{\text{leafwise paths}}{\text{leafwise path-homotopy}} \begin{array}{c} \xrightarrow{\text{t}} \\ \xrightarrow{\text{s}} \end{array} M$$

where the source and target maps take the initial and end points of the path:

$$\text{s} : \Pi(M, \mathcal{F}) \rightarrow M, \quad [\gamma] \mapsto \gamma(0), \quad \text{t} : \Pi(M, \mathcal{F}) \rightarrow M, \quad [\gamma] \mapsto \gamma(1),$$

and multiplication is defined, as usually, by concatenation of paths:

$$[\gamma_1] \circ [\gamma_2] := [\gamma_1 \circ \gamma_2] \quad \text{if} \quad \text{s}([\gamma_1]) = \text{t}([\gamma_2]).$$

In other words, this groupoid is the union of the homotopy groupoids of the leaves. To describe the smooth structure of $\Pi(M, \mathcal{F})$, fix a leafwise path

$\gamma : [0, 1] \rightarrow M$, with $\gamma(0) = x_0$ and $\gamma(1) = x_1$. Also, choose two foliation charts centered at x_0 and x_1 (see Section C.1):

$$\chi_i : U_i \xrightarrow{\sim} V_i \times W_i, \quad \chi_i(x_i) = (0, 0), \quad i \in \{0, 1\},$$

with $V_i \subset \mathbb{R}^p$ and $W_i \subset \mathbb{R}^q$ open contractible neighborhoods of the origin. One obtains, in particular, transversals to the leaf at x_0 and x_1 :

$$T_0 = \chi_0^{-1}(\{0\} \times W_0), \quad T_1 = \chi_1^{-1}(\{0\} \times W_1).$$

We need the following lemma which summarizes the construction of the *holonomy* of γ as a germ of diffeomorphism from (T_0, x_0) to (T_1, x_1) .

Lemma 13.28. *After possibly shrinking T_0 to a smaller neighborhood of x_0 , one can find a smooth map*

$$T_0 \times [0, 1] \rightarrow M, \quad (x, t) \mapsto \gamma^x(t),$$

such that $\gamma^{x_0} = \gamma$ and such that $\gamma^x : [0, 1] \rightarrow M$ is a leafwise path with $\gamma^x(0) = x$ and $\gamma^x(1) \in T_1$. Moreover, the map

$$(13.3) \quad \text{Hol}(\gamma) : T_0 \rightarrow T_1, \quad x \mapsto \gamma^x(1),$$

is a local diffeomorphism around x_0 , mapping x_0 to x_1 .

Exercise 13.29. Prove the previous lemma.

HINT: Cover γ by foliation charts, i.e., divide $[0, 1]$ into a finite number of intervals $[t_k, t_{k+1}]$, with $\gamma([t_k, t_{k+1}])$ inside a foliation chart, and then move along γ using the information from the foliation chart.

Now, for each $(w_0, v_0, v_1) \in W_0 \times V_0 \times V_1$, using the previous lemma and the fact that the V_i 's were chosen contractible, we have the following:

- (i) a leafwise path γ^x with $\gamma^x(0) = \chi(0, w_0)$ and $\gamma^x(1) = \chi(0, w_1)$,
- (ii) a leafwise path joining $\chi^{-1}(v_0, w_0)$ and $\gamma^x(0)$,
- (iii) a leafwise path joining $\gamma^x(1)$ and $\chi^{-1}(v_1, w_1)$.

Concatenating these three paths we find, for each $(w_0, v_0, v_1) \in W_0 \times V_0 \times V_1$, a path homotopy class in $\Pi(M, \mathcal{F})$. This defines a chart in $\Pi(M, \mathcal{F})$ with codomain $W_0 \times V_0 \times V_1 \subset \mathbb{R}^q \times \mathbb{R}^p \times \mathbb{R}^p$. A tedious but rather straightforward argument shows that all these charts cover $\Pi(M, \mathcal{F})$ and are smoothly compatible. Therefore this defines a smooth structure for $\Pi(M, \mathcal{F})$.

One can show that the germ of the diffeomorphism $\text{Hol}(\gamma)$ only depends on the leafwise homotopy class of γ . Also, one says that two leafwise paths γ_1 and γ_2 with the same initial and end points have the same **holonomy** if the germs of $\text{Hol}(\gamma_1)$ and $\text{Hol}(\gamma_2)$ coincide. Then the **holonomy groupoid** of (M, \mathcal{F}) is defined as

$$\text{Hol}(M, \mathcal{F}) := \frac{\text{leafwise paths}}{\text{path-holonomy}} \xrightarrow[\text{s}]{\text{t}} M$$

with multiplication induced by concatenation. One can also show that this is a Lie groupoid. There is an obvious surjective groupoid morphism

$$\Pi(M, \mathcal{F}) \rightarrow \text{Hol}(M, \mathcal{F}),$$

which is a local diffeomorphism. 

Example 13.30 (Poisson homotopy groupoid). Coming back to our main objects of study, recall that a Poisson manifold (M, π) gives rise to a groupoid

$$\Pi(M, \pi) := \frac{\text{cotangent paths}}{\text{cotangent path-homotopy}} \xrightarrow[\mathbf{s}]{\mathbf{t}} M$$

where the source and target maps give the initial and end points of a cotangent path:

$$\mathbf{s} : \Pi(M, \pi) \rightarrow M, \quad [a] \mapsto \gamma_a(0), \quad \mathbf{t} : \Pi(M, \pi) \rightarrow M, \quad [a] \mapsto \gamma_a(1).$$

Note that for this groupoid:

- The orbits are precisely the symplectic leaves.
- The isotropy groups are the Poisson homotopy groups introduced in Definition 10.26.

Also, inspired by the example of the fundamental groupoid, one may think of the principal isotropy bundle $\mathbf{t} : \mathbf{s}^{-1}(x) \rightarrow S_x$ as the **Poisson homotopy cover** of the symplectic leaf S_x .

The question now is whether $\Pi(M, \pi)$ can actually be made into a *Lie* groupoid. This turns out to be a delicate and important question, which will be discussed in the next chapter.

For a *complete* symplectic realization $\mu : (S, \omega) \rightarrow (M, \pi)$ we have seen that parallel transport gives rise to an action of $\Pi(M, \pi)$ on $\mu : S \rightarrow M$. We see now that this is indeed a groupoid action. Denote by \mathcal{F} the orbit foliation of the symplectic realization, and consider its homotopy groupoid $\Pi(S, \mathcal{F}) \rightrightarrows S$. Then the results of Section 12.5 give an isomorphism of groupoids

$$\Pi(M, \pi) \ltimes S \rightarrow \Pi(S, \mathcal{F}), \quad ([a], p) \mapsto [\tilde{\gamma}_a^p].$$

In the next chapter we will be able to add smoothness to this discussion.

13.3. The Lie algebroid of a Lie groupoid

We have already introduced the notion of a Lie algebroid — see Definition 9.1. In this section, we construct the Lie algebroid $(A, [\cdot, \cdot]_A, \rho)$ associated to an arbitrary Lie groupoid $\mathcal{G} \rightrightarrows M$.

For a Lie group G one can think of its Lie algebra \mathfrak{g} as the space of left-invariant vector fields. Similarly, given a Lie groupoid $\mathcal{G} \rightrightarrows M$, let us look for its left-invariant vector fields. The main difference is that, for an

arrow $g : x \rightarrow y$, the left-translation L_g is no longer defined on the entire \mathcal{G} , but only on the appropriate \mathfrak{t} -fibers:

$$L_g : \mathfrak{t}^{-1}(x) \rightarrow \mathfrak{t}^{-1}(y), \quad h \mapsto gh.$$

So, the notion of left-invariance only makes sense for vector fields tangent to \mathfrak{t} -fibers.

Definition 13.31. A **left-invariant** vector field on a Lie groupoid \mathcal{G} is a vector field $X \in \mathfrak{X}(\mathcal{G})$ satisfying the following:

- (i) X is tangent to the fibers of \mathfrak{t} .
- (ii) $d_h L_g(X_h) = X_{gh}$, whenever g and h are composable arrows.

We denote by $\mathfrak{X}_{\text{inv}}(\mathcal{G})$ the space of left-invariant vector fields on \mathcal{G} .

Exercise 13.32. Show that the Lie bracket of left-invariant vector fields is a left-invariant vector field.

Now observe that given a left-invariant vector field $X \in \mathfrak{X}_{\text{inv}}(\mathcal{G})$, the restriction $\alpha := X|_{u(M)}$ is a section of the vector bundle over M :

$$\text{Ker}(\text{dt})|_{u(M)} \cong u^* \text{Ker}(\text{dt}).$$

Conversely, given a section α of $\text{Ker}(\text{dt})|_{u(M)}$ we associate to it a left-invariant vector field by

$$\overleftarrow{\alpha} \in \mathfrak{X}_{\text{inv}}(\mathcal{G}), \quad \overleftarrow{\alpha}|_g := dL_g(\alpha|_{1_{\mathfrak{s}(g)}}).$$

Exercise 13.33. Show that for any section α of $u^* \text{Ker}(\text{dt})$ the left-invariant vector field $\overleftarrow{\alpha}$ is smooth.

It follows that left-invariant vector fields on a Lie groupoid $\mathcal{G} \rightrightarrows M$ are in 1-to-1 correspondence with sections of the vector bundle $u^* \text{Ker}(\text{dt})$.

Definition 13.34. The **Lie algebroid of a Lie groupoid** $\mathcal{G} \rightrightarrows M$ is the vector bundle

$$A := u^* \text{Ker}(\text{dt}) \rightarrow M,$$

with the anchor map $\rho : A \rightarrow TM$,

$$\rho_x = d_{1_x} \mathfrak{s} : A_x = (\text{Ker dt})|_{1_x} \rightarrow T_x M,$$

and the Lie bracket $[\cdot, \cdot]_A : \Gamma(A) \times \Gamma(A) \rightarrow \Gamma(A)$ defined by

$$\overleftarrow{[\alpha_1, \alpha_2]}_A = [\overleftarrow{\alpha}_1, \overleftarrow{\alpha}_2].$$

Theorem 13.35. $(A, [\cdot, \cdot]_A, \rho)$ is a Lie algebroid.

Proof. We have already noticed that we have a bijection

$$\Gamma(A) \xrightarrow{\sim} \mathfrak{X}_{\text{inv}}(\mathcal{G}), \quad \alpha_1 \mapsto \overleftarrow{\alpha}_1,$$

and that the bracket of left-invariant vector fields is a left-invariant vector field. Therefore, we get a Lie bracket $[\cdot, \cdot]_A : \Gamma(A) \times \Gamma(A) \rightarrow \Gamma(A)$.

It remains to check the Leibniz identity. For this, note that

$$\overleftarrow{(f \alpha_2)} = \mathbf{s}^*(f) \overleftarrow{\alpha}_2,$$

so we deduce that

$$\overleftarrow{[\alpha_1, f \alpha_2]_A} = [\overleftarrow{\alpha}_1, \mathbf{s}^*(f) \overleftarrow{\alpha}_2]_A = \mathbf{s}^*(f) [\overleftarrow{\alpha}_1, \overleftarrow{\alpha}_2]_A + \mathcal{L}_{\overleftarrow{\alpha}_1}(\mathbf{s}^*(f)) \overleftarrow{\alpha}_2.$$

Now observe that the vector fields $\overleftarrow{\alpha}_1$ and $\rho(\alpha_1)$ are \mathbf{s} -related, so we have

$$\mathcal{L}_{\overleftarrow{\alpha}_1}(\mathbf{s}^*(f)) = \mathbf{s}^*(\mathcal{L}_{\rho(\alpha_1)}(f)).$$

We conclude that

$$\overleftarrow{[\alpha_1, f \alpha_2]_A} = \overleftarrow{f[\alpha_1, \alpha_2]_A + \mathcal{L}_{\rho(\alpha_1)}(f)\alpha_2},$$

so the Leibniz identity holds. □

Given a Lie groupoid $\mathcal{G} \rightrightarrows M$ we denote by $\text{Lie}(\mathcal{G})$ its Lie algebroid.

Definition 13.36. A Lie algebroid $A \rightarrow M$ is called **integrable** if there is some Lie groupoid $\mathcal{G} \rightrightarrows M$ and a Lie algebroid isomorphism $A \simeq \text{Lie}(\mathcal{G})$. In this case, we call $\mathcal{G} \rightrightarrows M$ an **integration** of A .

It may be surprising to learn that not every Lie algebroid is integrable. In the next chapter, integrability will play an important role.

Let $\mathcal{G} \rightrightarrows M$ be a Lie groupoid with Lie algebroid $A \rightarrow M$. We say that $\alpha \in \Gamma(A)$ is a **complete section** if the vector field $\rho(\alpha)$ is complete. The following result will be used in the next chapter:

Proposition 13.37. *If $\alpha \in \Gamma(A)$ is a complete section of A , then the left-invariant vector field $\overleftarrow{\alpha} \in \mathfrak{X}(\mathcal{G})$ is complete.*

Proof. Notice first that the left-invariant vector field $\overleftarrow{\alpha} \in \mathfrak{X}(\mathcal{G})$ is \mathbf{s} -related to the vector field $\rho(\alpha) \in \mathfrak{X}(M)$:

$$\text{ds}(\overleftarrow{\alpha}|_g) = \text{ds}(dL_g(\alpha|_{1_{\mathbf{s}(g)}})) = \text{ds}(\alpha|_{1_{\mathbf{s}(g)}}) = \rho(\alpha),$$

where we have used that $\mathbf{s} \circ L_g = \mathbf{s}$.

Assuming now that $\alpha \in \Gamma(A)$ is a complete section, let $g(t)$ be an integral curve $\overleftarrow{\alpha} \in \mathfrak{X}(\mathcal{G})$ defined in an interval (a, b) . The integral curve $\mathbf{s}(g(t))$ of $\rho(\alpha)$ can be extended to an integral curve $\gamma(t)$ that is defined for all $t \in \mathbb{R}$.

Assuming $b < \infty$, we let $h(t)$ be the the integral curve of $\overleftarrow{\alpha}$ with $h(b) = 1_{\gamma(b)}$. The curve $h(t)$ is defined in some interval $(b - 2\varepsilon, b + \delta)$. Now the curve

$$\tilde{g}(t) := \begin{cases} g(t) & \text{if } t \in (a, b - \varepsilon], \\ g(b - \varepsilon)h(b - \varepsilon)^{-1}h(t) & \text{if } t \in (b - \varepsilon, b + \delta) \end{cases}$$

is an integral curve of $\overleftarrow{\alpha}$, extending the curve $g(t)$ and defined in $(a, b + \delta)$. An entirely similar argument also applies for a , so we conclude that integral curves of $\overleftarrow{\alpha}$ exist for all t . \square

A Lie groupoid morphism

$$\begin{array}{ccc} \mathcal{G} & \xrightarrow{\Phi} & \mathcal{H} \\ \downarrow & & \downarrow \\ M & \xrightarrow{\varphi} & N \end{array}$$

maps \mathbf{t} -fibers to \mathbf{t} -fibers, and therefore we can define the bundle map

$$\begin{array}{ccc} \text{Lie}(\mathcal{G}) & \xrightarrow{\Phi_*} & \text{Lie}(\mathcal{H}) \\ \downarrow & & \downarrow \\ M & \xrightarrow{\varphi} & N \end{array} \quad (\Phi_*)_x := d\Phi|_{(\text{Ker } dt)|_{1_x}}$$

Theorem 13.38. *Given a Lie groupoid morphism $\Phi : \mathcal{G} \rightarrow \mathcal{H}$, the map*

$$\Phi_* : \text{Lie}(\mathcal{G}) \rightarrow \text{Lie}(\mathcal{H})$$

is a Lie algebroid morphism.

Proof. Set $A := \text{Lie}(\mathcal{G})$, $B := \text{Lie}(\mathcal{H})$, and $\phi := \Phi_* : A \rightarrow B$. Recall that ϕ is a Lie algebroid morphism if and only if it commutes with the Lie algebroid differentials:

$$(13.4) \quad \phi^* d_B = d_A \phi^*.$$

To check this we observe that algebroid forms $\Omega^k(A)$ can be identified with left-invariant forms on the Lie groupoid \mathcal{G} . Again, one must be careful to define left-invariant forms since left-translations are only defined along the \mathbf{t} -fibers. Consider the foliation of \mathcal{G} by \mathbf{t} -fibers and define a left-invariant form on \mathcal{G} to be a \mathbf{t} -foliated form $\omega \in \Omega^k(\text{Ker } dt)$ such that for every pair of composable arrows $(g, h) \in \mathcal{G}^{(2)}$ one has

$$\omega_{gh}(dL_g(v_1), \dots, dL_g(v_k)) = \omega_h(v_1, \dots, v_k),$$

whenever $v_1, \dots, v_k \in \text{Ker } d_h \mathbf{t}$. Denoting by $\Omega_{\text{inv}}^\bullet(\mathcal{G})$ the space of left-invariant forms, we then have an isomorphism

$$\Omega_{\text{inv}}^\bullet(\mathcal{G}) \xrightarrow{\sim} \Omega^\bullet(A), \quad \omega \mapsto \omega|_M.$$

The foliated de Rham differential preserves left-invariant forms and this isomorphism intertwines the foliated de Rham differential and the Lie algebroid differential.

Now, to prove (13.4) one observes that a groupoid morphism $\Phi : \mathcal{G} \rightarrow \mathcal{H}$ pulls back left-invariant forms to left-invariant forms. Under the identification between left-invariant forms and Lie algebroid forms, the pullback by Φ corresponds to the pullback by ϕ . Hence ϕ^* intertwines the differentials. \square

In general, if $\phi : \text{Lie}(\mathcal{G}) \rightarrow \text{Lie}(\mathcal{H})$ is a Lie algebroid morphism and $\Phi : \mathcal{G} \rightarrow \mathcal{H}$ is a Lie groupoid morphism such that $\Phi_* = \phi$, we say that Φ **integrates** ϕ . Note that already a morphism of Lie algebras $\phi : \mathfrak{g} \rightarrow \mathfrak{h}$ does need to integrate to a morphism of Lie groups $\Phi : G \rightarrow H$. However, integrations of morphisms, if they exist, are unique, provided the target fibers of the domain are connected.

Given a Lie algebroid $A \rightarrow M$ a **Lie subalgebroid** $B \rightarrow N$ is a Lie algebroid together with an injective Lie algebroid morphism $i : B \hookrightarrow A$ covering an immersion.

Exercise 13.39. Show that if $\mathcal{H} \rightrightarrows N$ is a Lie subgroupoid of $\mathcal{G} \rightrightarrows M$, then $\text{Lie}(\mathcal{H})$ is a Lie subalgebroid $\text{Lie}(\mathcal{G})$.

13.4. Lie algebroids: Examples and basic constructions

In this section we recall the examples of Lie algebroids we have seen before and we look at new examples. We also relate them to the examples of Lie groupoids we have already discussed. We will keep an eye on what those examples tell us about general Lie algebroids.

Example 13.40 (The tangent bundle). A basic example of Lie algebroid is the tangent bundle of a manifold $A = TM$ with anchor $\text{Id} : TM \rightarrow TM$ and the usual Lie bracket of vector fields. For any Lie algebroid $(A, [\cdot, \cdot]_A, \rho)$, the anchor $\rho : A \rightarrow TM$ is a morphism of Lie algebroids.

Exercise 13.41. Show that the pair groupoid $M \times M \rightrightarrows M$ of Example 13.10 and the fundamental groupoid $\Pi(M) \rightrightarrows M$ of Example 13.12 are both integrations of TM . Show also that for any Lie groupoid $\mathcal{G} \rightrightarrows M$ the map $(\mathbf{t}, \mathbf{s}) : \mathcal{G} \rightarrow M \times M$ is a morphism of Lie groupoids integrating the anchor $\rho : \text{Lie}(\mathcal{G}) \rightarrow TM$. 

Example 13.42 (Lie algebras). Recall that a Lie algebra is the same as a Lie algebroid over a point.

For a general Lie algebroid $(A, [\cdot, \cdot]_A, \rho)$, one associates a Lie algebra to each point $x \in M$, called the **isotropy Lie algebra** of A at x

$$\mathfrak{g}_x(A) := \text{Ker}(\rho_x : A_x \rightarrow T_x M),$$

with Lie algebra structure induced from $[\cdot, \cdot]_A$:

Exercise 13.43. Show that there exists a Lie algebra bracket on $\mathfrak{g}_x = \mathfrak{g}_x(A)$,

$$[\cdot, \cdot]_{\mathfrak{g}_x} : \mathfrak{g}_x \times \mathfrak{g}_x \rightarrow \mathfrak{g}_x,$$

such that, for any $\alpha, \beta \in \Gamma(A)$ with $\alpha(x), \beta(x) \in \mathfrak{g}_x$, one has

$$[\alpha, \beta]_A(x) = [\alpha(x), \beta(x)]_{\mathfrak{g}_x}.$$

Notice that the inclusion $\mathfrak{g}_x(A) \hookrightarrow A$ is a Lie algebroid morphism. If A is the Lie algebroid of a Lie groupoid $\mathcal{G} \rightrightarrows M$, then $\mathfrak{g}_x(A)$ is the Lie algebra of the isotropy Lie group $\mathcal{G}_x \hookrightarrow \mathcal{G}$. 

Example 13.44 (Bundles of Lie algebras). Bundles of Lie algebras are the same as Lie algebroids $A \rightarrow M$ with vanishing anchor map: $\rho \equiv 0$.

For any Lie algebroid A one can put together the isotropy Lie algebras

$$\mathfrak{g}(A) := \text{Ker}(\rho) \subset A.$$

In general, this is not a bundle of Lie algebras because the dimension of the isotropy Lie algebras can vary. One calls A a **regular Lie algebroid** if this dimension is constant. In this case, $\mathfrak{g}(A)$ is a bundle of Lie algebras and one has a short exact sequence of Lie algebroid morphisms

$$0 \longrightarrow \text{Ker}(\rho) \longrightarrow A \xrightarrow{\rho} TM \longrightarrow 0. \quad \text{fish icon}$$

Example 13.45 (Vector fields). Given a vector $X \in \mathfrak{X}(M)$, one can define a Lie algebroid structure on the trivial line bundle $\mathbb{R}_M := M \times \mathbb{R} \rightarrow M$ with anchor,

$$\rho_X(x, \lambda) = \lambda X_x,$$

and Lie bracket on $\Gamma(\mathbb{R}_M) = C^\infty(M)$ given by

$$[f, g]_X := f \mathcal{L}_X(g) - g \mathcal{L}_X(f).$$

Conversely, a Lie algebroid structure on the trivial line bundle \mathbb{R}_M defines a vector field X , namely the anchor map applied to the constant function 1. The Leibniz identity implies that the bracket takes the above form.

Therefore, there is a 1-to-1 correspondence

$$\left\{ \begin{array}{l} \text{vector fields} \\ X \in \mathfrak{X}(M) \end{array} \right\} \xleftrightarrow{\sim} \left\{ \begin{array}{l} \text{Lie algebroid structures} \\ \text{on the trivial line bundle } \mathbb{R}_M \end{array} \right\}.$$

Exercise 13.46. Given $X \in \mathfrak{X}(M)$, show that its flow groupoid $\mathcal{D}(X) \rightrightarrows M$, as in Example 13.14, has Lie algebroid $(\mathbb{R}_M, [\cdot, \cdot]_X, \rho_X)$. 

Example 13.47 (Action algebroids). A Lie algebra action $\mathfrak{a} : \mathfrak{g} \rightarrow \mathfrak{X}(M)$ gives rise to an **action Lie algebroid** where the vector bundle $A \rightarrow M$ is the trivial bundle with fiber \mathfrak{g} , the anchor is given by

$$\rho : M \times \mathfrak{g} \rightarrow TM, \quad (x, v) \mapsto \mathfrak{a}(v)_x,$$

and the Lie bracket on the space of sections $\Gamma(A) \simeq C^\infty(M; \mathfrak{g})$ is defined by

$$[f, g](x) = [f(x), g(x)]_{\mathfrak{g}} + (\mathcal{L}_{\mathfrak{a}(f(x))}g)(x) - (\mathcal{L}_{\mathfrak{a}(g(x))}f)(x).$$

We will denote this Lie algebroid by $\mathfrak{g} \ltimes M \rightarrow M$.

Notice that the Lie algebroid associated with a vector field is a special case of this construction.

Exercise 13.48. Given an action of a Lie group G on a manifold M with induced infinitesimal action $\mathfrak{a} : \mathfrak{g} \rightarrow \mathfrak{X}(M)$, show that the action Lie groupoid $G \ltimes M \rightrightarrows M$ from Example 13.13 has Lie algebroid the action Lie algebroid $\mathfrak{g} \ltimes M \rightarrow M$. In other words,

$$\text{Lie}(G \ltimes M) = \text{Lie}(G) \ltimes M \quad \text{🐟}$$

Example 13.49 (Actions of Lie algebroids). An **action of a Lie algebroid** $A \rightarrow M$ on a map $\mu : S \rightarrow M$ is defined to be a Lie algebra homomorphism

$$\mathfrak{a} : \Gamma(A) \rightarrow \mathfrak{X}(S)$$

which is

(i) $C^\infty(M)$ -linear:

$$\mathfrak{a}(f\alpha) = \mu^*(f) \mathfrak{a}(\alpha) \quad \forall f \in C^\infty(M), \alpha \in \Gamma(A),$$

(ii) compatible with the anchor:

$$d\mu(\mathfrak{a}(\alpha)_p) = \rho(\alpha)_p, \quad \forall p \in S.$$

Note that the $C^\infty(M)$ -linearity means that \mathfrak{a} can also be viewed as a vector bundle map $\mathfrak{a} : \mu^*A \rightarrow TS$. When $A = \mathfrak{g}$ is a Lie algebra, the second condition is void, and this notion of action reduces to the notion of a Lie algebra action on a manifold S . In the language of Remark 12.27, a Lie algebroid action on a surjective submersion is the same as a flat nonlinear A -connection.

Given a Lie algebroid action $\mathfrak{a} : \mu^*A \rightarrow TS$, we can form the **action algebroid** $A \ltimes S$ generalizing the action algebroid of a Lie algebra action. The underlying vector bundle is the pullback bundle μ^*A , the anchor map is the action itself,

$$\rho_{A \ltimes S} = \mathfrak{a} : \mu^*A \rightarrow TS,$$

while the Lie bracket is defined on pullback sections by

$$[\mu^*(\alpha), \mu^*(\beta)]_{A \ltimes S} = \mu^*([\alpha, \beta]_A)$$

and then extended to any sections by requiring the Leibniz identity to hold.

If a Lie groupoid $\mathcal{G} \rightrightarrows M$ acts on a map $\mu : S \rightarrow M$, there is an induced action of the Lie algebroid $A = \text{Lie}(\mathcal{G})$ on $\mu : S \rightarrow M$. It is defined as follows. For $p \in S$, we set $x = \mu(p)$, we consider the map

$$(13.5) \quad \mathcal{R}_p : \mathfrak{t}^{-1}(\mu(p)) \rightarrow S, \quad g \mapsto g^{-1} \cdot p,$$

and we take its differential at the unit 1_x :

$$(13.6) \quad \alpha_p : A_x \rightarrow T_p S, \quad \alpha_p := d_x \mathcal{R}_p.$$

Given a Lie algebroid action $\alpha : \mu^* A \rightarrow TS$, by an **integration of the action** we mean a Lie groupoid \mathcal{G} integrating A , together with an action of \mathcal{G} on $\mu : S \rightarrow M$ inducing the infinitesimal action.

Exercise 13.50. Let $\mathcal{G} \rightrightarrows M$ be a Lie groupoid which acts on a map $\mu : S \rightarrow M$. Show that the action Lie groupoid $\mathcal{G} \times S \rightrightarrows S$ integrates the action algebroid $\text{Lie}(\mathcal{G}) \times S$. 

Example 13.51 (General linear Lie algebroid $\mathfrak{gl}(E)$). Let $E \rightarrow M$ be a vector bundle. One defines a **derivation** of E to be a linear map

$$D : \Gamma(E) \rightarrow \Gamma(E)$$

satisfying the Leibniz identity

$$D(f s) = f D(s) + \mathcal{L}_{X_D}(f) s, \quad \forall f \in C^\infty(M), s \in \Gamma(E),$$

for some vector field $X_D \in \mathfrak{X}(M)$. This vector field is unique and is called the **symbol** of D . Let $\text{Der}(E)$ denote the space of derivations. Note the following:

- (i) The commutator of derivations

$$[D_1, D_2] := D_1 \circ D_2 - D_2 \circ D_1$$

is again a derivation, so $(\text{Der}(E), [\cdot, \cdot])$ is a Lie algebra.

- (ii) The symbol map

$$\rho : \text{Der}(E) \rightarrow \mathfrak{X}(M)$$

is a Lie algebra map.

This suggests that $\text{Der}(E)$ is the space of sections of a Lie algebroid.

Exercise 13.52. Denote by $\mathfrak{gl}(E)$ the Lie algebroid of the general Lie groupoid $\text{GL}(E) \rightrightarrows M$ introduced in Example 13.22. Show that there is a linear isomorphism

$$\Gamma(\mathfrak{gl}(E)) \cong \text{Der}(E)$$

which takes the Lie bracket and the anchor of $\mathfrak{gl}(E)$ into the commutator bracket and the symbol map on $\text{Der}(E)$.

A derivation D with vanishing symbol $X_D \equiv 0$ is just a $C^\infty(M)$ -linear endomorphism of $\Gamma(E)$, i.e., a section of $\text{End}(E)$. On the other hand, if one chooses a connection ∇ on $E \rightarrow M$, a vector field $X \in \mathfrak{X}(M)$ defines a derivation $D := \nabla_X$ with symbol $X_D = X$. This shows that the anchor $\rho : \mathfrak{gl}(E) \rightarrow TM$ is surjective. In conclusion, we have a short exact sequence of Lie algebroids

$$0 \longrightarrow \text{End}(E) \longrightarrow \mathfrak{gl}(E) \xrightarrow{\rho} TM \longrightarrow 0 ,$$

where $\text{End}(E)$ is a bundle of Lie algebras equipped with the fiberwise commutator. Note that a choice of a connection ∇ on E can be interpreted as a choice of a splitting of this sequence and it yields a noncanonical isomorphism of vector bundles

$$\mathfrak{gl}(E) \simeq \text{End}(E) \oplus TM. \tag{fish}$$

Example 13.53 (Tangent Lie algebroid). The following construction can be thought of as applying the tangent functor to Lie algebroids. For a Lie algebroid $p : A \rightarrow M$ one obtains a Lie algebroid

$$dp : TA \rightarrow TM,$$

as we now explain. The vector bundle structure comes from differentiating the vector bundle structure on A . The anchor is simply

$$d\rho : TA \rightarrow T(TM).$$

For the Lie bracket one notes that a section $\alpha \in \Gamma(A)$ induces two different types of sections of TA :

- a *linear* section $d\alpha : TM \rightarrow TA$,
- a *core* section $\widehat{\alpha} : TM \rightarrow TA$:

$$\widehat{\alpha}(v_x) := v_x + \alpha(x) \in T_xM \oplus A_x \simeq T_{0_x}A.$$

These sections generate over $C^\infty(TM)$ all other sections. One defines the Lie bracket $[\cdot, \cdot]_{TA}$ by setting, for $\alpha, \beta \in \Gamma(A)$,

$$[\widehat{\alpha}, \widehat{\beta}]_{TA} = 0, \quad [d\alpha, \widehat{\beta}]_{TA} = \widehat{[\alpha, \beta]}_A, \quad [d\alpha, d\beta]_{TA} = d[\alpha, \beta]_A.$$

Exercise 13.54. Given a Lie groupoid $\mathcal{G} \rightrightarrows M$ with Lie algebroid $A \rightarrow M$, show that the tangent groupoid $T\mathcal{G} \rightrightarrows TM$ from Example 13.21 has Lie algebroid the tangent algebroid $TA \rightarrow TM$. In other words, we have

$$\text{Lie}(T\mathcal{G}) = T \text{Lie}(\mathcal{G}).$$

One can also look for a cotangent algebroid T^*A . This notion is a bit more subtle and it will be discussed in Section 13.5.

As in Example 13.21 we can also form the double direct sum $\bigoplus^2 TA$ of the tangent Lie algebroid $TA \rightarrow TM$, a Lie algebroid with vector bundle

$$\bigoplus^2 TA := TA \oplus_A TA \rightarrow \bigoplus^2 TM := TM \oplus_M TM$$

and with anchor and bracket defined componentwise. To describe them more precisely, we introduce a special type of sections of TA . Namely, we call $X \in \Gamma_{TM}(TA)$ **fibred** if it covers a section $\alpha_X \in \Gamma(A)$:

$$\begin{array}{ccc} TM & \xrightarrow{X} & TA \\ \text{pr} \downarrow & & \downarrow \text{pr} \\ M & \xrightarrow{\alpha_X} & A \end{array}$$

For example a linear section $d\alpha$ is fibred over α and a core section $\hat{\alpha}$ is fibred over the zero section.

Exercise 13.55. Show that if $X, Y \in \Gamma_{TM}(TA)$ are fibred sections, then so is $[X, Y]_{TA}$.

A pair $X_1, X_2 \in \Gamma_{TM}(TA)$ defines a section $X_1 \oplus X_2 \in \Gamma_{\bigoplus^2 TM}(\bigoplus^2 TA)$ if and only if both are fibred and cover the same section $\alpha_{X_1} = \alpha_{X_2}$. Then, for $X_i, Y_i \in \Gamma_{TM}(TA)$ defining sections $X_1 \oplus X_2$ and $Y_1 \oplus Y_2$ of $\bigoplus^2 TA$, one defines

$$\begin{aligned} \rho_{\bigoplus^2 TA}(X_1 \oplus X_2) &:= \rho_{TA}(X_1) \oplus \rho_{TA}(X_2), \\ [X_1 \oplus X_2, Y_1 \oplus Y_2]_{\bigoplus^2 TA} &:= [X_1, Y_1]_{TA} \oplus [X_2, Y_2]_{TA}. \end{aligned}$$

We leave it as an exercise to check that this indeed defines a Lie algebroid.

Similarly, one defines the Lie algebroids $\bigoplus^k TA$ over $\bigoplus^k TM$. Then one can show that the Lie functor commutes with taking direct sums, so that

$$\text{Lie}\left(\bigoplus^k T\mathcal{G}\right) = \bigoplus^k \text{Lie}(T\mathcal{G}) = \bigoplus^k T\text{Lie}(\mathcal{G}). \quad \curvearrowright$$

Example 13.56 (Pullback algebroids). Let $(A, [\cdot, \cdot]_A, \rho)$ be a Lie algebroid over M and let $\mu : S \rightarrow M$ be a smooth map. Consider the fiber product

$$\mu^! A := A \times_{TM} TS = \{(\alpha, v) \in A \times TS : \rho(\alpha) = d\mu(v)\}.$$

In general, this may fail to be a vector bundle over S . However, under some condition, e.g., if μ is transverse to ρ , this will be a vector subbundle of $A \times_M TS \rightarrow S$. Assuming that this is the case, we can define on this vector

bundle a Lie algebroid structure where the following hold:

- The anchor is the projection on TS .
- The Lie bracket is defined on sections of $\mu^!A$ of the form (α, X) , with $\alpha \in \Gamma(A)$ and $X \in \mathfrak{X}(S)$, by

$$[(\alpha_1, X_1), (\alpha_2, X_2)]_{\mu^!A} := ([\alpha_1, \alpha_2]_A, [X_1, X_2])$$

and then is extended to all sections using the Leibniz identity.

The resulting Lie algebroid $\mu^!A$ is called the **pullback Lie algebroid** of A by the map $\mu : S \rightarrow M$.

We have already seen an instance of this construction. If $\mu : S \rightarrow M$ is a surjective submersion, this construction gives the underlying Lie algebroid of the pullback Dirac structure. However, this fails for general maps μ .

Exercise 13.57. Let $\mu : S \rightarrow M$ be a submersion. Show that the pullback Lie groupoid $\mu^!\mathcal{G} \rightrightarrows S$ of the groupoid $\mathcal{G} \rightrightarrows M$ defined in Example 13.18 has Lie algebroid isomorphic to the pullback Lie algebroid $\mu^!\text{Lie}(\mathcal{G})$. 

Example 13.58 (Atiyah algebroids). Let $\text{pr} : P \rightarrow M$ be a principal G -bundle. The lifted action on $TP \rightarrow P$ is by vector bundle isomorphisms, so we have the quotient vector bundle

$$TP/G \rightarrow M.$$

Sections of this vector bundle are canonically identified with G -invariant vector fields $X \in \mathfrak{X}(P)$. Hence, on this vector bundle we have a natural Lie algebroid structure, where the following hold:

- The anchor is given by the differential of the projection: $\rho := d \text{pr}$.
- The Lie bracket on sections is just the usual Lie bracket on vector fields restricted to invariant vector fields.

One calls $(TP/G, [\cdot, \cdot], \rho)$ the **Atiyah algebroid** of the principal bundle.

Note the following:

- (i) A G -invariant vector field $X \in \mathfrak{X}(P)$ which is in the kernel $d \text{pr}$ can be canonically identified with an equivariant map $P \rightarrow \mathfrak{g}$, where G acts on \mathfrak{g} via the adjoint action.
- (ii) An equivariant map $P \rightarrow \mathfrak{g}$ can be canonically identified with a section of the adjoint bundle $P[\mathfrak{g}] := P \times_G \mathfrak{g}$.

Therefore, we have a short exact sequence of Lie algebroids

$$0 \longrightarrow P[\mathfrak{g}] \longrightarrow TP/G \xrightarrow{\rho} TM \longrightarrow 0$$

where the adjoint bundle is viewed as a bundle of Lie algebras with the Lie algebra structure on the fibers induced from \mathfrak{g} .

Exercise 13.59. Show that the Atiyah Lie algebroid TP/G is the Lie algebroid of the gauge groupoid $\text{Gauge}_G(P)$ from Example 13.15.

One says that $(A, [\cdot, \cdot]_A, \rho)$ is a **transitive Lie algebroid** if the anchor ρ is surjective. So a transitive Lie algebroid can be seen as part of a short exact sequence of Lie algebroids

$$0 \longrightarrow \mathfrak{g}(A) \longrightarrow A \xrightarrow{\rho} TM \longrightarrow 0.$$

This may be thought of as an “abstract Atiyah sequence” because of the following exercise:

Exercise 13.60. Let \mathcal{G} be a Lie groupoid integrating a transitive Lie algebroid A . If the base is connected, show that \mathcal{G} is transitive and that A is isomorphic to the Atiyah Lie algebroid of any of its isotropy principal \mathcal{G}_x -bundles $\mathfrak{t} : \mathfrak{s}^{-1}(x) \rightarrow M$. 

Example 13.61 (Prequantization algebroids). Let $\omega \in \Omega^2(M)$ be a closed 2-form on a manifold M and consider the vector bundle

$$A_\omega := TM \oplus \mathbb{R}.$$

Let $\rho : A_\omega \rightarrow TM$ be the projection on the first factor and define a bracket on the sections $\Gamma(A_\omega) = \mathfrak{X}(M) \times C^\infty(M)$ by

$$[(X, f), (Y, g)] := ([X, Y], \mathcal{L}_X(g) - \mathcal{L}_Y(f) + \omega(X, Y)).$$

This bracket is \mathbb{R} -bilinear and skew-symmetric and satisfies the Leibniz identity. The Jacobi identity is equivalent to ω being closed. We call $(A_\omega, [\cdot, \cdot], \rho)$ the **prequantization Lie algebroid** of the closed 2-form ω .

This is a transitive algebroid with “abstract Atiyah sequence”

$$0 \longrightarrow \mathbb{R}_M \longrightarrow A_\omega \xrightarrow{\rho} TM \longrightarrow 0,$$

where \mathbb{R}_M is the trivial line bundle with zero bracket and zero anchor map.

We define a **central Lie algebroid extension** of TM by \mathbb{R}_M to be any transitive algebroid A with isotropy Lie algebra bundle \mathbb{R}_M such that the constant section 1 of \mathbb{R}_M commutes with all other sections of A .

Exercise 13.62. Define the notion of isomorphism of central extensions of TM by \mathbb{R}_M and show the following:

- (a) Any central extension A of TM by \mathbb{R}_M is isomorphic to A_ω for some closed form $\omega \in \Omega^2(M)$.
- (b) Given $\omega_1, \omega_2 \in \Omega^2(M)$ closed forms, the corresponding central extensions are isomorphic if and only if ω_1 and ω_2 are cohomologous.

The name “prequantization algebroid” derives from the so-called *prequantization problem*:

- Given a closed 2-form ω , does it represent the first Chern class of a complex line bundle? Equivalently, does there exist a principal \mathbb{S}^1 -bundle $\text{pr} : P \rightarrow M$ and a connection 1-form $\theta \in \Omega^1(P)$ such that $d\theta = \text{pr}^* \omega$?

One calls such a principal \mathbb{S}^1 -bundle a **prequantization bundle** for ω .

Exercise 13.63. Show that if P is a prequantization bundle for ω , then the associated gauge groupoid $\text{Gauge}_{\mathbb{S}^1}(P)$ is an integration of the Lie algebroid A_ω . Hence, if ω is prequantizable, then A_ω must be integrable.

One can show that A_ω is integrable if and only if the *group of spherical periods* of ω ,

$$\text{Per}(\omega) := \left\{ \int_\gamma \omega : \gamma \in \pi_2(M) \right\} \subset (\mathbb{R}, +),$$

is a discrete subgroup. Using this, it is easy to produce examples of nonintegrable Lie algebroids! 

Example 13.64 (Foliations). Recall that foliations on a manifold M are in 1-to-1 correspondence with involutive subbundles of TM , i.e., subalgebroids of the tangent bundle. So we may say that foliations *are the same* as Lie algebroids with injective anchor map.

This explains our search in Example 13.27 for “desingularizations” of the equivalence relation $\text{Rel}(\mathcal{F})$: we were just looking for Lie groupoids \mathcal{G} integrating $T\mathcal{F}$.

Exercise 13.65. Show that the homotopy groupoid $\Pi(M, \mathcal{F}) \rightrightarrows M$ and the holonomy groupoid $\text{Hol}(M, \mathcal{F}) \rightrightarrows M$ from Example 13.27 are both integrations of $T\mathcal{F}$.

Now observe that for a regular Lie algebroid $(A, [\cdot, \cdot], \rho)$, since the anchor preserves Lie brackets, we obtain a foliation \mathcal{F}_A of M such that

$$T\mathcal{F}_A = \text{Im } \rho \subset TM.$$

One calls \mathcal{F}_A the **orbit foliation** of A and its leaves the **orbits** of A .

If A is not regular, one can still talk about the **orbits** of A , which admit the following descriptions:

- If A comes from a Lie groupoid $\mathcal{G} \rightrightarrows M$, the orbits of A coincide with the connected component of the orbits of \mathcal{G} .

- In general, as in the proof of Theorem 4.1, using an algebroid version of the Weinstein Splitting Theorem — see [59, Thm. 8.5.1] — one constructs

the maximal integral submanifolds of the singular distribution $\text{Im } \rho \subset TM$. These are the orbits of A .

- The orbit foliation \mathcal{F}_A can be described set theoretically quite easily: $x, y \in M$ are in the same orbit of A if and only if they can be joined by the base path of an A -path, i.e., if and only if there exists

$$\gamma : [0, 1] \rightarrow M, \quad \text{with } \gamma(0) = x, \gamma(1) = y,$$

and a path $a : [0, 1] \rightarrow A$, sitting above γ , such that

$$\rho(a(t)) = \frac{d\gamma}{dt}(t) \quad (t \in [0, 1]).$$

One can put a smooth structure on these set-theoretical orbits using again the Lie algebroid version of the Weinstein Splitting Theorem.

- Alternatively, the submodule of vector fields $\text{Im } \rho \subset \mathfrak{X}(M)$ defines a singular foliation and the orbits are obtained by the singular version of the Frobenius Theorem — see Section C.3. 

Example 13.66 (Cotangent algebroids). The most important example for us is, of course, the cotangent bundle $(T^*M, [\cdot, \cdot]_\pi, \pi^\sharp)$ of a Poisson manifold. The orbits of this Lie algebroid are the symplectic leaves of the Poisson manifold and the isotropy Lie algebras also coincide.

In the next chapter we will see that, when the Poisson homotopy groupoid $\Pi(M, \pi) \rightrightarrows M$ is smooth, then its Lie algebroid is isomorphic to the cotangent algebroid $(T^*M, [\cdot, \cdot]_\pi, \pi^\sharp)$.

Note also that the infinitesimal action $\mathfrak{a} : \mu^*T^*M \rightarrow TS$ associated to a symplectic realization $\mu : (S, \omega) \rightarrow (M, \pi)$ — see Definition 12.2 — can now be interpreted as a Lie algebroid action of the cotangent algebroid T^*M on $\mu : S \rightarrow M$. Moreover the resulting action Lie algebroid $T^*M \ltimes S$ is isomorphic to the orbit foliation

$$T^*M \ltimes S \xrightarrow{\simeq} T\mathcal{F}.$$

It is not surprising that this is related to the action of $\Pi(M, \pi) \rightrightarrows M$ on a complete symplectic realization $\mu : (S, \omega) \rightarrow (M, \pi)$ discussed in Example 13.30. In the next chapter, when we add smoothness to this discussion, we will see that the above isomorphism is the infinitesimal version of the groupoid isomorphism from Example 13.30.

13.5. Duals of Lie algebroids

There is yet another very important connection between Poisson geometry and Lie algebroid theory: the same way one can view Lie algebra structures as linear Poisson structures, one can view Lie algebroid structures as *fiber-wise linear* Poisson structures on a vector bundle. This gives an entirely

new perspective on the notion of Lie algebroid and also provides a large list of new, interesting examples of Poisson structures: the duals of all the examples from the previous section!

In order to define the notion of a fiberwise linear Poisson structures on a vector bundle $\text{pr} : E \rightarrow M$ we consider the scalar multiplication operation along the fibers

$$m_t : E \rightarrow E, \quad v \mapsto tv.$$

Note that for $t \neq 0$ this is a vector bundle automorphism.

Definition 13.67. A multivector field $\vartheta \in \mathfrak{X}^{k+1}(E)$ on the total space of a vector bundle $E \rightarrow M$ is called **fiberwise linear** if

$$(m_t)_*\vartheta = t^k\vartheta, \quad \forall t > 0.$$

The space of fiberwise linear multivector fields is denoted by $\mathfrak{X}_{\text{lin}}^\bullet(E)$.

Exercise 13.68. Show that the subspace $\mathfrak{X}_{\text{lin}}^\bullet(E) \subset \mathfrak{X}^\bullet(E)$ is closed under the Schouten bracket (but not under the wedge product!).

In degree 0, $\mathfrak{X}_{\text{lin}}^0(E) = C^\infty_{\text{lin}}(E)$ consists of the functions whose restriction to the fibers are linear. These fiberwise linear functions are precisely the evaluation functions $\text{ev}_\alpha \in C^\infty(E)$ on a section $\alpha \in \Gamma(E^*)$ of the dual vector bundle.

In order to see what happens in higher degrees, choose local coordinates (U, x^1, \dots, x^n) for M over which E admits a trivializing frame $\{e_1, \dots, e_r\}$. This yields local coordinates (x^i, ξ^a) on $\text{pr}^{-1}(U)$. We leave it as an exercise to check that $\vartheta \in \mathfrak{X}^{k+1}(E)$ is fiberwise linear if and only if it takes the form

$$\begin{aligned} \vartheta = & \sum_{i, a_1 < \dots < a_k} \vartheta^{i, a_1 \dots a_k}(x) \frac{\partial}{\partial x^i} \wedge \frac{\partial}{\partial \xi^{a_1}} \wedge \dots \wedge \frac{\partial}{\partial \xi^{a_k}} \\ & + \sum_{a_1 < \dots < a_{k+1}, b} \vartheta_b^{a_1 \dots a_{k+1}}(x) \xi^b \frac{\partial}{\partial \xi^{a_1}} \wedge \dots \wedge \frac{\partial}{\partial \xi^{a_{k+1}}}. \end{aligned}$$

In particular, a bivector field $\pi \in \mathfrak{X}^2(E)$ is fiberwise linear if and only if for any such choice of coordinates it takes the form

$$\pi = \sum_{i, a} \pi^{i, a}(x) \frac{\partial}{\partial x^i} \wedge \frac{\partial}{\partial \xi^a} + \sum_{a < b, c} \pi_c^{ab}(x) \xi^c \frac{\partial}{\partial \xi^a} \wedge \frac{\partial}{\partial \xi^b}.$$

Note that if we think of a vector space as a vector bundle over a point, then fiberwise linear bivector fields are just linear bivector fields. The following exercise gives another characterization of fiberwise linear bivector fields,

generalizing what happens for a vector spaces:

Exercise 13.69. Show that a bivector field $\pi \in \mathfrak{X}^2(E)$ is fiberwise linear if and only if the corresponding biderivation $\{\cdot, \cdot\} : C^\infty(E) \times C^\infty(E) \rightarrow C^\infty(E)$ satisfies

$$\{C_{\text{lin}}^\infty(E), C_{\text{lin}}^\infty(E)\} \subset C_{\text{lin}}^\infty(E).$$

Finally, we state the main result of this section:

Theorem 13.70. *Given a vector bundle $\text{pr} : A \rightarrow M$, there is a 1-to-1 correspondence*

$$\left\{ \begin{array}{l} \text{Lie algebroid} \\ \text{structures on } A \end{array} \right\} \xleftrightarrow{\sim} \left\{ \begin{array}{l} \text{fiberwise linear} \\ \text{Poisson structures on } A^* \end{array} \right\}.$$

Under this correspondence, the Poisson bracket $\{\cdot, \cdot\}_{A^*}$ corresponding to a Lie algebroid structure $(A, [\cdot, \cdot]_A, \rho)$ is uniquely determined by the conditions

$$(13.7) \quad \{\text{ev}_\alpha, \text{ev}_\beta\}_{A^*} = \text{ev}_{[\alpha, \beta]_A},$$

where $\text{ev}_\alpha \in C^\infty(A^*)$ is the evaluation on $\alpha \in \Gamma(A)$.

Remark 13.71. The condition (13.7) has some hidden consequences. Replacing β by $f\beta$, with $f \in C^\infty(M)$ arbitrary, and using the Leibniz identity both for $\{\cdot, \cdot\}_{A^*}$ and for $[\cdot, \cdot]_A$, one obtains that

$$(13.8) \quad \{\text{ev}_\alpha, \text{pr}^* f\}_{A^*} = \text{pr}^* (\mathcal{L}_{\rho(\alpha)}(f)).$$

Then replacing α by $g\alpha$, a similar argument implies that

$$(13.9) \quad \{\text{pr}^* f, \text{pr}^* g\}_{A^*} = 0. \quad \img alt="fish icon" data-bbox="828 617 863 638"/>$$

We can use equations (13.7), (13.8), and (13.9) to find the expression in local coordinates for the bivector field π_A in terms of the local Lie algebroid data. Choosing a chart (U, x^1, \dots, x^n) on M over which A admits a trivializing frame $\{e_1, \dots, e_r\}$, the Lie algebroid structure is encoded by structure functions $B_a^i, C_{ab}^c \in C^\infty(U)$ defined by

$$(13.10) \quad \rho(e_a) = \sum_i B_a^i(x) \frac{\partial}{\partial x^i}, \quad [e_a, e_b] = \sum_c C_{ab}^c(x) e_c.$$

Then on the dual bundle A^* we have local coordinates $(x^1, \dots, x^n, y_1, \dots, y_r)$ with $y_a(\xi) = \xi(e_a)$. With respect to these coordinates any bivector field on A^* satisfying (13.7), (13.8), and (13.9) must be given by

$$(13.11) \quad \pi_A = \sum_{i,a} B_a^i(x) \frac{\partial}{\partial y_a} \wedge \frac{\partial}{\partial x^i} + \sum_{a < b, c} C_{ab}^c(x) y_c \frac{\partial}{\partial y_a} \wedge \frac{\partial}{\partial y_b}.$$

Exercise 13.72. Show that the structure functions $B_a^i, C_{ab}^c \in C^\infty(U)$ of a Lie algebroid satisfy the system of PDEs

$$\sum_j \left(B_a^j \frac{\partial B_b^i}{\partial x^j} - B_b^j \frac{\partial B_a^i}{\partial x^j} \right) = \sum_c B_c^i C_{ab}^c,$$

$$\sum_i \left(B_a^i \frac{\partial C_{bc}^d}{\partial x^i} + B_b^i \frac{\partial C_{ca}^d}{\partial x^i} + B_c^i \frac{\partial C_{ab}^d}{\partial x^i} \right) = \sum_e \left(C_{ea}^d C_{bc}^e + C_{eb}^d C_{ca}^e + C_{ec}^d C_{ab}^e \right).$$

Verify that these equations are also equivalent to the vanishing of the Schouten bracket $[\pi_A, \pi_A] = 0$, where π_A is given by (13.11).

One can also give a coordinate-free expression for the fiberwise linear Poisson structure π_A , by choosing an auxiliary connection on the vector bundle $A \rightarrow M$.

Exercise 13.73. Let $(A, [\cdot, \cdot]_A, \rho)$ be a Lie algebroid, and let ∇ be an ordinary connection on the vector bundle $A \rightarrow M$. Let $T_\nabla : A \otimes A \rightarrow A$ be the torsion of the associate A -connection

$$T_\nabla(\alpha, \beta) := \nabla_{\rho(\alpha)}\beta - \nabla_{\rho(\beta)}\alpha - [\alpha, \beta], \quad \forall \alpha, \beta \in \Gamma(A).$$

(a) Show that the horizontal spaces of ∇ induce a splitting of T^*A^* :

$$T_{\xi_x}^* A^* = A_x \oplus T_x^* M, \quad \xi_x \in A_x^*.$$

(b) Show that (13.11) is the expression in local coordinates for the bivector field on A^* given by

$$\pi_A(\sigma_1, \sigma_2) := \langle \rho(a_1), \alpha_2 \rangle - \langle \rho(a_2), \alpha_1 \rangle - \langle T_\nabla(a_1, a_2), \xi_x \rangle,$$

where $\sigma_i = a_i + \alpha_i \in A_x \oplus T_x^* M$ denotes the decomposition of $\sigma_i \in T_{\xi_x}^* A^*$ relative to the splitting in (a).

Proof of Theorem 13.70. Given a Lie algebroid structure $(A, [\cdot, \cdot]_A, \rho)$, in local coordinates as above, we have structure functions $B_a^i, C_{ab}^c \in C^\infty(U)$ defined by (13.10). In the dual local coordinates on A^* , we can define a fiberwise linear bivector field π_A by (13.11). By Exercise 13.72, this is a Poisson bivector, and by what we have seen above, it is the unique one satisfying (13.7). By local uniqueness, one obtains a global Poisson bivector. Alternatively, one can also invoke Exercise 13.73 to show that (13.11) does not depend on the local coordinates.

Conversely, given a fiberwise linear Poisson structure $\pi_A \in \mathfrak{X}_{\text{lin}}^2(A^*)$, with associated Poisson bracket $\{\cdot, \cdot\}_{A^*}$ we construct a Lie algebroid structure $(A, [\cdot, \cdot]_A, \rho)$. By Exercise 13.69 the Lie bracket $\{\cdot, \cdot\}_{A^*}$ restricts to a Lie bracket $[\cdot, \cdot]_A$ on $C_{\text{lin}}^\infty(A^*) \simeq \Gamma(A)$, satisfying

$$(13.12) \quad \{\text{ev}_\alpha, \text{ev}_\beta\}_{A^*} = \text{ev}_{[\alpha, \beta]_A}, \quad \forall \alpha, \beta \in \Gamma(A).$$

Since π_A is fiberwise linear, it follows that the Poisson bracket of a fiberwise linear function with a fiberwise constant one is fiberwise constant:

$$\{ev_\alpha, pr^* f\}_{A^*} = pr^*(X(\alpha, f)), \quad X(\alpha, f) \in C^\infty(M).$$

By applying the Leibniz identity in f , we obtain that $X(\alpha, f)$ is a derivation in f . By replacing α by $g\alpha$ and using that the Poisson bracket of fiberwise constant functions is zero, it follows that $X(\alpha, f)$ is $C^\infty(M)$ -linear in α . Therefore there is a bundle map $\rho : A \rightarrow TM$ such that $X(\alpha, f) = \mathcal{L}_{\rho(\alpha)}(f)$. As in Remark 13.71, in (13.12) we replace β by $f\beta$, and we obtain that $[\cdot, \cdot]_A$ satisfies the Leibniz identity with respect to ρ . \square

Example 13.74. By Exercise 1.18, for $A = TM$, the fiberwise linear Poisson structure on T^*M is $\pi_{TM} = \omega_{can}^{-1}$. 

Under the correspondence between Lie algebroids $(A, [\cdot, \cdot]_A, \rho)$ and fiberwise linear Poisson structures (A^*, π_A) one has the following:

- (i) Lie algebroid maps $\phi : A \rightarrow B$ covering the identity correspond to vector bundle maps $\phi^* : (B^*, \pi_B) \rightarrow (A^*, \pi_A)$ covering the identity that are Poisson maps.
- (ii) Lie ideals I of A — i.e., subbundles $I \subset \text{Ker } \rho$ such that $\Gamma(I)$ is an ideal in $\Gamma(A)$ — correspond to vector subbundles $I^\circ \subset (A^*, \pi_A)$ that are Poisson submanifolds.

Let us look a bit more into the Poisson geometry of (A^*, π_A) .

Proposition 13.75. Let $(A, [\cdot, \cdot]_A, \rho)$ be a Lie algebroid. The corresponding fiberwise linear Poisson structure $\pi_A \in \mathfrak{X}_{lin}^2(A^*)$ satisfies the following:

- (i) The zero section is a coisotropic submanifold of A^* .
- (ii) For any orbit $\mathcal{O} \subset M$ of A , the immersion of the cotangent bundle $(T^*\mathcal{O}, \omega_{can})$ given by

$$i : T^*\mathcal{O} \hookrightarrow A^*, \quad \alpha_x \mapsto \rho_x^*(\alpha_x)$$

is a symplectic leaf of A^* .

Proof. The map $\tau : A^* \rightarrow A^*$, $\tau(v) = -v$ is an anti-Poisson involution; therefore its fixed point set, i.e., the zero section of A^* , is a coisotropic submanifold — see Proposition 8.71.

Let $\mathcal{O} \subset M$ be an orbit. It follows easily — for example from the local expression of π_A — that $A^*|_{\mathcal{O}}$ is a Poisson submanifold of (A^*, π_A) . Moreover, the induced Poisson structure on $A^*|_{\mathcal{O}}$ is the fiberwise linear Poisson structure $\pi_{A|_{\mathcal{O}}}$ corresponding to the restricted Lie algebroid $A|_{\mathcal{O}}$. By varying the orbit, the collection of such Poisson submanifolds gives a partition of A^* . Therefore, Problem 8.6 implies that $A^*|_{\mathcal{O}}$ is a complete

Poisson submanifold. Thus it suffices to check the result for the transitive Lie algebroid $A|_{\mathcal{O}} \rightarrow \mathcal{O}$.

By Example 13.74, $\omega_{\text{can}} = \pi_{T\mathcal{O}}^{-1}$, and using that the anchor $\rho : A|_{\mathcal{O}} \rightarrow T\mathcal{O}$ is a Lie algebroid morphism, we obtain by property (i) above a Poisson embedding with closed image

$$\rho^* : (T^*\mathcal{O}, \omega_{\text{can}}) \rightarrow (A^*|_{\mathcal{O}}, \pi_{A|_{\mathcal{O}}}).$$

Therefore, by Problem 8.6 its image is a symplectic leaf. □

Assume now that $(A, [\cdot, \cdot]_A, \rho)$ is an integrable Lie algebroid with integration $\mathcal{G} \rightrightarrows M$. In contrast to the case of duals of Lie algebras, in general, there is no “coadjoint action” of \mathcal{G} on A^* giving the symplectic leaves. The “coadjoint orbits” should now be defined as the symplectic leaves of (A^*, π_A) . However, there is still a canonical groupoid that morally encodes such a coadjoint action. It is called the **cotangent Lie groupoid** of \mathcal{G} ,

$$T^*\mathcal{G} \rightrightarrows A^*,$$

and it is defined as follows:

- For $\xi_g \in T_g^*\mathcal{G}$ where $g : x \rightarrow y$, one defines its source and target by

$$\begin{aligned} \mathbf{s}(\xi_g) &\in A_x^*, & \mathbf{s}(\xi_g)(\alpha_x) &= \xi_g(d_x L_g(\alpha_x)), \\ \mathbf{t}(\xi_g) &\in A_y^*, & \mathbf{t}(\xi_g)(\beta_y) &= -\xi_g(d_y R_g(d_y \iota(\beta_y))). \end{aligned}$$

- For $\xi_g \in T_g^*\mathcal{G}$ and $\eta_h \in T_h^*\mathcal{G}$ we define a covector $\xi_g \oplus \eta_h \in T_{(g,h)}^*\mathcal{G}^{(2)}$ by setting

$$\xi_g \oplus \eta_h(v_g, w_h) := \xi_g(v_g) + \eta_h(w_h).$$

If ξ_g and η_h are composable, then $\xi_g \oplus \eta_h$ vanishes on $\text{Ker } d_{(g,h)} \mathbf{m} \subset T_{(g,h)}\mathcal{G}^{(2)}$, so there exists a unique $\xi_g \cdot \eta_h \in T_{gh}^*\mathcal{G}$ such that

$$\xi_g \oplus \eta_h = (d_{(g,h)} \mathbf{m})^*(\xi_g \cdot \eta_h).$$

Note that $\mathbf{s}(\xi_g \cdot \eta_h) = \mathbf{s}(\eta_h)$ and $\mathbf{t}(\xi_g \cdot \eta_h) = \mathbf{t}(\xi_g)$.

- The unit map $\mathbf{u} : A_x^* \rightarrow T_x^*\mathcal{G}$ is the inclusion arising from the decomposition of $T_x^*\mathcal{G}$ dual to $T_x\mathcal{G} = T_x M \oplus A_x$.
- The inversion $\iota : T^*\mathcal{G} \rightarrow T^*\mathcal{G}$ is the transpose of the differential of the inversion of \mathcal{G} .

You should check that when $A = \mathfrak{g}$ is a Lie algebra and $\mathcal{G} = G$ is a Lie group integrating \mathfrak{g} , this construction yields a groupoid $T^*G \rightrightarrows \mathfrak{g}^*$ isomorphic to the coadjoint action groupoid $G \ltimes \mathfrak{g}^* \rightrightarrows \mathfrak{g}^*$. The analogue of

this for an arbitrary algebroid can be stated as follows:

Proposition 13.76. *For any Lie groupoid $\mathcal{G} \rightrightarrows M$ with Lie algebroid A , its cotangent bundle $T^*\mathcal{G} \rightrightarrows A^*$ is a Lie groupoid with Lie algebroid isomorphic to the cotangent Lie algebroid T^*A^* of the Poisson manifold (A^*, π_A) . In particular, the symplectic leaves of A^* are the connected components of the orbits of $T^*\mathcal{G}$.*

This result will follow from the theory of symplectic groupoids, to be discussed in the next chapter — see Example 14.24.

13.6. The Lie philosophy

The passage from Lie groupoids to Lie algebroids is an instance of the “Lie philosophy”, much like the passage from Lie groups to Lie algebras. Other instances are the passage from Lie group actions to infinitesimal Lie algebra actions, from Lie groupoid morphisms to Lie algebroid morphisms, etc. The advantage of passing from global to infinitesimal via “differentiation” comes from the fact that, while the infinitesimal side of the story is more tractable, very little (sometimes nothing!) is lost by passing to it. Moreover, often one can go backwards via “integration”, such as integrating vector fields, constructing parallel transport with respect to connections, recovering a Lie group from its Lie algebra, etc.

Underlying the Lie philosophy are the three basic “Lie Theorems”, which we discuss next. The integration part of these theorems requires an assumption, which in the context of Lie groupoids takes the form “**1-connected \mathfrak{t} -fibers**”. By this we mean that the target fibers are connected and simply connected. This assumption is not too restrictive and the first two of these theorems state the following:

Theorem 13.77 (Lie I). *If A is an integrable Lie algebroid, then A admits a unique, up to isomorphism, integration \mathcal{G} with 1-connected \mathfrak{t} -fibers.*

Theorem 13.78 (Lie II). *Let \mathcal{G} and \mathcal{H} be two Lie groupoids, with Lie algebroids denoted A and B , respectively. If \mathcal{G} has 1-connected \mathfrak{t} -fibers, then any morphism of Lie algebroids $\phi : A \rightarrow B$ integrates to a unique morphism of Lie groupoids $\Phi : \mathcal{G} \rightarrow \mathcal{H}$.*

These two theorems are not very hard to prove with the methods discussed so far in this book. However, Lie’s First Theorem requires one to consider non-Hausdorff Lie groupoids, even for some simple classes of examples such as bundles of Lie algebras and foliations. Since Lie’s First Theorem may give rise to non-Hausdorff groupoids, it is helpful to know that Lie’s Second Theorem continues to hold in the non-Hausdorff setting. See the detailed discussion in Section 13.7.

Lie's Third Theorem is more delicate and is the hardest one to prove. In the case of ordinary Lie groups and Lie algebras, it can be stated as follows:

Theorem 13.79 (Lie III for Lie algebras). *Any finite-dimensional Lie algebra \mathfrak{g} is integrable.*

As we have already pointed out, a Lie algebroid *does not* necessarily integrate to a Lie groupoid, so there is not a straightforward analogue of this result for Lie algebroids. However, this failure is by now well understood and there are several equivalent characterizations for integrability.

First of all, one can construct a candidate for integrating A , namely the *A-homotopy groupoid*

$$\Pi(A) := \frac{A\text{-paths}}{A\text{-path homotopy}} \begin{array}{c} \xrightarrow{\mathfrak{s}} \\ \xrightarrow{\mathfrak{t}} \end{array} M$$

which is always defined as a set-theoretical groupoid. Here A -paths and A -path homotopies are defined as Lie algebroid morphisms, exactly as for cotangent paths and cotangent path-homotopies. In constructing this groupoid one can show the following:

- (i) The space of *all* C^1 -paths $a : [0, 1] \rightarrow A$ with C^2 base path $\gamma_a : [0, 1] \rightarrow M$ has a natural structure of Banach manifold. The subspace $P(A) := \{A\text{-paths}\}$ is a Banach submanifold — still infinite dimensional.
- (ii) The equivalence relation \sim defined by “ A -path homotopy” gives a foliation \mathcal{F}_{Big} on the Banach manifold $P(A)$ by leaves of finite codimension equal to $\dim A = \text{rank } A + \dim M$.
- (iii) The quotient topology on the leaf space $\Pi(A) = P(A)/\sim$ of the foliation \mathcal{F}_{Big} makes $\Pi(A) \rightrightarrows M$ into a topological groupoid with 1-connected target fibers.

The groupoid $\Pi(A)$ is often called the **Weinstein groupoid** of A . The question now is if the smooth structure on the Banach manifold $P(A)$ descends to the leaf space $\Pi(A) = P(A)/\sim$. In fact, one has the following version of Lie's Third Theorem for Lie algebroids:

Theorem 13.80 (Crainic and Fernandes [41]). *A Lie algebroid A is integrable if and only if the smooth structure on the Banach manifold $P(A)$ descends to the leaf space $\Pi(A) = P(A)/\sim$. In this case, $\Pi(A) \rightrightarrows M$ is a Lie groupoid with 1-connected \mathfrak{t} -fibers and its Lie algebroid is isomorphic to A .*

Again, the correct setting for this theorem is that of non-Hausdorff Lie groupoids, in the sense explained in Section 13.7. In general, even if A

is integrable by a Hausdorff Lie groupoid, the Lie groupoid $\Pi(A)$ may be non-Hausdorff. This can happen already for a bundle of Lie algebras.

The smoothness of $\Pi(A) \rightrightarrows M$ is controlled by the so-called **monodromy map**, which is a group homomorphism

$$\partial_x : \pi_2(\mathcal{O}_x) \rightarrow \Pi(\mathfrak{g}_x) \quad (x \in M),$$

where $\Pi(\mathfrak{g}_x)$ is the 1-connected Lie group integrating the Lie algebra \mathfrak{g}_x . In [41] necessary and sufficient conditions for the integrability of A are expressed in terms of the image of this homomorphism. Although these results are beyond the scope of this book, let us point out some consequences:

- For a Lie algebra \mathfrak{g} , the monodromy map is trivial, which explains why Lie III holds.
- For a Poisson manifold (M, π) , we have $\Pi(T^*M) = \Pi(M, \pi)$. So if $(T^*M, [\cdot, \cdot]_\pi, \pi^\sharp)$ is integrable, then $\Pi(M, \pi) \rightrightarrows M$ is a Lie groupoid with Lie algebroid $(T^*M, [\cdot, \cdot]_\pi, \pi^\sharp)$.
- For a regular Poisson manifold, $\mathfrak{g}_x = \nu^*(S_x)$ is abelian and the monodromy map is given by the variation of symplectic areas map

$$A'_x : \pi_2(S_x) \rightarrow \nu_x^*(S_x)$$

studied in Section 10.6. A necessary condition for $(T^*M, [\cdot, \cdot]_\pi, \pi^\sharp)$ to be integrable is that the image of this map is discrete.

We refer the reader to [41, 45] for proofs and much more information about Lie algebroids, Lie groupoids, and the integration problem. In the next chapter we will discuss the groupoids associated to Poisson manifolds. For now we illustrate how the Lie philosophy can simplify and bring extra insight into a problem in Poisson geometry discussed earlier.

Example 13.81. Given a Poisson structure (M, π) with a zero x , with no smoothness assumption on $\Pi(M, \pi) \rightrightarrows M$, we constructed in Example 10.30 an isomorphism

$$\Psi : \Pi(\mathfrak{g}) \rightarrow \Pi(M, \pi, x),$$

where $\mathfrak{g} = \text{Ker } \pi_x^\sharp$ is the isotropy Lie algebra. Here we give another interpretation of this construction using the Lie philosophy.

We identify $\Pi(\mathfrak{g})$ with the universal cover of a fixed Lie group G integrating \mathfrak{g} , so that $\Pi(\mathfrak{g}) = P(G, e)/\sim$, the quotient of the set $P(G, e)$ of paths in G starting at e modulo path-homotopy. Denoting by $P(\mathfrak{g})$ the collection of all paths in \mathfrak{g} , the isomorphism Ψ was induced by the map

$$\tilde{\Psi} : P(G, e) \rightarrow P(\mathfrak{g}), \quad g(t) \mapsto a(t) := \left. \frac{d}{ds} \right|_{s=t} g(t)^{-1}g(s).$$

Here is the extra insight that the Lie philosophy brings. The main remark is that, while paths in \mathfrak{g} can be interpreted as algebroid morphism

$$a dt : TI \rightarrow \mathfrak{g} \quad (I = [0, 1]),$$

paths $g \in P(G, e)$ are in 1-to-1 correspondence with groupoid morphisms

$$\tilde{g} : I \times I \rightarrow G.$$

This 1-to-1 correspondence is determined by

$$\tilde{g}(t, s) = g(t)^{-1}g(s), \quad g(s) = \tilde{g}(0, s).$$

Of course, given g , differentiating the groupoid morphism \tilde{g} one obtains precisely the path $a = \tilde{\Psi}(g)$. Hence part (i) of Lemma 10.32, i.e., the 1-to-1 correspondence $\tilde{\Psi}$, can be seen as an instance of Lie’s Second Theorem.

The situation is completely similar for homotopies, i.e., part (ii) of Lemma 10.32. Again, maps $h = h(t, \varepsilon) : I \times I \rightarrow G$ satisfying $h(0, 0) = e$ are in 1-to-1 correspondence with groupoid morphisms defined on the pair groupoid of the square $J = I \times I$:

$$\tilde{h} : J \times J \rightarrow G, \quad \tilde{h}((t_1, \varepsilon_1), (t_2, \varepsilon_2)) := h(t_1, \varepsilon_1)^{-1}h(t_2, \varepsilon_2).$$

By differentiation one recovers Lie algebroid maps $TJ \rightarrow \mathfrak{g}$, i.e., maps Φ satisfying (10.12). The boundary conditions (10.13) corresponds to the fact that h is a path-homotopy. Since J is 1-connected one can appeal again to Lie’s Second Theorem and one recovers (ii) of Lemma 10.32. 

13.7. The non-Hausdorff setting

In the last part of the book we will allow certain manifolds to be non-Hausdorff. Recall however that all our manifolds will be assumed to be second countable. The reasons for these are twofold: on the one hand, some very natural examples of Lie groupoids are non-Hausdorff and, on the other hand, both Lie’s First and Third Theorems require one to consider non-Hausdorff groupoids.

Example 13.82 (Bundles of Lie algebras). The trivial bundle of Lie algebras $\text{pr}_1 : \mathbb{R} \times \mathbb{R} \rightarrow \mathbb{R}$ is integrated by the trivial bundle of groups with fiber $(\mathbb{R}, +)$. Another smooth but non-Hausdorff integration is obtained as the quotient

$$\mathcal{G} = (\mathbb{R} \times \mathbb{R})/\Lambda, \quad \Lambda_t = \begin{cases} \mathbb{Z}, & t < 0, \\ 0, & t \geq 0. \end{cases}$$

More interesting examples, which show the need of non-Hausdorff Lie groupoids, were discovered by Douady and Lazard [55] in their study of integrations of families of Lie algebras. Consider the family of Lie algebras

$A = \mathbb{R} \times \mathbb{R}^3 \rightarrow \mathbb{R}$, where the Lie bracket at $t \in \mathbb{R}$ on the standard generators e_1 , e_2 , and e_3 is given by

$$(13.13) \quad [e_1, e_2] = e_3, \quad [e_2, e_3] = t e_1, \quad [e_3, e_1] = e_2.$$

In other words, $A \rightarrow \mathbb{R}$ is a Lie algebroid with zero anchor. In our language, Douady and Lazard show that $\mathcal{G} = \Pi(A) \rightarrow \mathbb{R}$ is a smooth non-Hausdorff groupoid. In fact, it is a smooth bundle of Lie groups, each fiber being a 1-connected Lie group integrating $(\mathbb{R}^3, [\cdot, \cdot]_t)$. They find another bundle of groups $\overline{\mathcal{G}} \rightarrow \mathbb{R}$, which is Hausdorff and still integrates A . Finally, they also find an example which exhibits another phenomenon: a bundle of Lie algebras $B = \mathbb{R} \times \mathbb{R}^3 \rightarrow \mathbb{R}$ which does not admit any Hausdorff integration. The bracket is given explicitly by

$$(13.14) \quad [e_1, e_2]_t = e_3 + \eta(-t)e_2, \quad [e_2, e_3]_t = \eta(t)e_1, \quad [e_3, e_1]_t = e_2 - \eta(-t)e_3,$$

where $\eta : \mathbb{R} \rightarrow \mathbb{R}$ is a smooth functions such that $\eta(t) = 0$ for $t \leq 0$ and $\eta(t) > 0$ for $t > 0$. By allowing non-Hausdorff manifolds, Douady and Lazard show that any bundle of Lie algebras is integrable. 

Example 13.83 (Foliations). Consider the foliation \mathcal{F} of $M = \mathbb{R}^3 \setminus \{0\}$ by horizontal planes $z = c$ and its homotopy groupoid $\Pi(M, \mathcal{F}) \rightrightarrows M$ — recall Example 13.27. This groupoid is non-Hausdorff: the homotopy class $[\gamma] \in \Pi(M, \mathcal{F})$ of a loop γ in the leaf $z = 0$ around the origin cannot be separated from the trivial loop starting at the same point. Hence, the homotopy groupoid is a smooth but non-Hausdorff manifold. On the other hand, because the foliation is simple, the holonomy groupoid is Hausdorff: $\text{Hol}(M, \mathcal{F}) \simeq M \times_{\mathbb{R}} M$. As in the case of Lie algebra bundle, there are foliations which do not admit any Hausdorff integration. 

We begin by discussing some general constructions on possibly non-Hausdorff manifolds. In full generality, notions that are local in nature can be introduced in a similar way in the non-Hausdorff setting.

The non-Hausdorff manifolds we consider come naturally with an involutive distribution. We make the assumption that the corresponding foliation has Hausdorff leaves, and this is the key which allows us to do usual differential geometry along the leaves.

The notion of a **foliation** is introduced the same way: as a partition into connected immersed submanifolds admitting a foliation atlas. On the other hand, for a constant rank subbundle

$$\mathcal{D} \subset TS$$

on a possibly non-Hausdorff manifold S , one must consider the local version of involutivity. We say that \mathcal{D} is **involutive** if, for any open set $U \subset S$,

$$[X, Y] \in \Gamma(U, \mathcal{D}), \quad \forall X, Y \in \Gamma(U, \mathcal{D}).$$

This condition is imposed because on a non-Hausdorff manifold some germs of sections might not come from global sections.

The **Local Frobenius Theorem, Theorem C.4**, does not require any changes, but the **Global Frobenius Theorem, Theorem C.3**, requires more care. More precisely:

- The **leaves** of \mathcal{D} are the equivalence classes with respect to the equivalence relation on S given by $x \sim y$ iff there is a path $\gamma : [0, 1] \rightarrow S$ from x to y which is tangent to \mathcal{D} .
- The Local Frobenius Theorem provides the local foliated charts, and also charts for the leaves.

One obtains:

Proposition 13.84. *The leaves of \mathcal{D} are connected immersed submanifolds of S forming a foliation.*

Example 13.85. If $\mu : S \rightarrow M$ is a submersion with connected fibers, then $\mathcal{D} := \text{Ker}(d\mu)$ is involutive and its leaves are precisely the fibers of μ . For a concrete example, consider the plane with a double line, i.e., the product of the line with two origins with \mathbb{R} :

$$P := (\mathbb{R} \cup_{\mathbb{R}^*} \mathbb{R}) \times \mathbb{R}.$$

The two projections pr_1 and pr_2 give rise to two foliations on P :

- \mathcal{F}_1 with leaves all copies of \mathbb{R} ,
- \mathcal{F}_2 with leaves all copies of a line with a double point $(\mathbb{R} \cup_{\mathbb{R}^*} \mathbb{R})$.



Notice that in the non-Hausdorff case bump functions can no longer be used and that there are serious problems with uniqueness of integral curves and therefore making sense of flows and completeness of vector fields. To make sense of this, we will use foliations with **Hausdorff leaves**.

Definition 13.86. Let S be a possibly non-Hausdorff manifold. Given a foliation \mathcal{F} with Hausdorff leaves, a vector field $V \in \mathfrak{X}(\mathcal{F}) = \Gamma(T\mathcal{F})$ is said to be **complete** if, for each leaf L of \mathcal{F} , $V|_L \in \mathfrak{X}(L)$ is complete in the usual sense. We define its **flow** $\phi_V^t : S \rightarrow S$ by using the flow along the leaves

$$(\phi_V^t)|_L = \phi_{V|_L}^t.$$

Although ϕ_V^t is now defined on each leaf at a time, locally it is still governed by the usual local existence and uniqueness for ODEs and the smooth dependence on parameters. Therefore, one still has the following very useful property:

Lemma 13.87. *If \mathcal{F} is a foliation with Hausdorff leaves and $V \in \mathfrak{X}(\mathcal{F})$ is complete, then $\phi_V^t : S \rightarrow S$ is a 1-parameter group of diffeomorphisms.*

It is useful to remark that the construction of the homotopy groupoid

$$\Pi(S, \mathcal{F}) \rightrightarrows S$$

carries over to the setting of foliations with Hausdorff leaves on a possibly non-Hausdorff manifold S . Over each leaf $L \subset S$, one has the homotopy groupoid of the leaf

$$\Pi(S, \mathcal{F})|_L = \Pi(L) \rightrightarrows L.$$

One observes that the notion of holonomy and the related Lemma 13.28 do not use that the ambient manifold is Hausdorff. A careful inspection of the discussion carried out in Example 13.27 shows that the smooth structure on $\Pi(S, \mathcal{F})$, as described there, still has the main properties:

Lemma 13.88. *For any foliation \mathcal{F} with Hausdorff leaves, the total space of the homotopy groupoid*

$$\Pi(S, \mathcal{F}) \rightrightarrows S$$

is a smooth manifold, \mathbf{s} and \mathbf{t} are submersions, and all other structure maps are smooth. Moreover, its \mathbf{s} - and \mathbf{t} -fibers are diffeomorphic to the homotopy covers of the leaves of \mathcal{F} ; hence they are Hausdorff.

Example 13.89. The foliation \mathcal{F}_1 on the manifold P from Example 13.85 has Hausdorff leaves, whereas the foliation \mathcal{F}_2 does not. The homotopy groupoid of \mathcal{F}_1 is

$$\Pi(P, \mathcal{F}_1) \simeq (\mathbb{R} \cup_{\mathbb{R}^*} \mathbb{R}) \times \mathbb{R} \times \mathbb{R} \rightrightarrows (\mathbb{R} \cup_{\mathbb{R}^*} \mathbb{R}) \times \mathbb{R}.$$

Geometrically, this consists of path-homotopy classes of paths in lines parallel to the double line. Two arrows cannot be separated precisely when both their start points as well as their end points cannot be separated.

We have already remarked that we need to consider non-Hausdorff groupoids for Lie's First and Third Theorems to hold true. Non-Hausdorff groupoids over a Hausdorff base still have some reasonable properties:

Proposition 13.90. *A possibly non-Hausdorff Lie groupoid $\mathcal{G} \rightrightarrows M$ over a Hausdorff base has Hausdorff \mathbf{t} -fibers.*

We defer the proof for later. Based on this result, we have the following convention:

Convention 13.91. *For a Lie groupoid $\mathcal{G} \rightrightarrows M$, we assume the following:*

- *The total space \mathcal{G} is a possibly non-Hausdorff manifold.*
- *The base is a Hausdorff manifold.*

These conditions imply that the \mathfrak{t} -fibers are Hausdorff manifolds.

In what follows, we will explain that basically all results of this chapter continue to hold in the non-Hausdorff setting, with certain simple adaptations. The main reason why the entire theory works the same way as for Hausdorff Lie groupoids is that most constructions for Lie groupoids are performed along Hausdorff manifolds, namely along the \mathfrak{t} - and \mathfrak{s} -fibers, or involve flows of vector fields that are tangent to one of these foliations.

For instance, the Lie algebroid of a possibly non-Hausdorff groupoid is constructed in the same way using left-invariant sections, hence vector fields along the \mathfrak{t} -fibers, and the result is a usual Lie algebroid. Since left-invariant and right-invariant vector fields are tangent to the \mathfrak{t} - and \mathfrak{s} -fibers, they have well-defined flows, which are complete if the corresponding sections are complete; i.e., Proposition 13.37 holds. The orbits of the Lie groupoid are still immersed submanifolds, being quotients of the Hausdorff \mathfrak{s} -fibers by the action of the Hausdorff isotropy groups. The restriction of the groupoid to such an orbit becomes a usual Hausdorff Lie groupoid. Also the proof of Proposition 13.7 clearly does not use Hausdorffness, and in fact not even Hausdorffness of the \mathfrak{t} -fibers.

Finally, let us stress that when we say that a Lie algebroid $A \rightarrow M$ is integrable, we mean that there exists a possibly non-Hausdorff Lie groupoid $\mathcal{G} \rightrightarrows M$ with Lie algebroid isomorphic A . Moreover, for an integrable Lie algebroid, $\Pi(A) \rightrightarrows M$ is a possibly non-Hausdorff Lie groupoid.

Still, it is a very interesting problem to decide whether an integrable Lie algebroid A is **Hausdorff integrable**, i.e., admits a Hausdorff integration and, in particular, whether $\Pi(A) \rightrightarrows M$ is Hausdorff — see [54] and [117] for first results.

Remark 13.92. A related and equally interesting problem is to decide whether an integrable Lie algebroid A is **Riemannian integrable**, i.e., whether it admits an integration which carries a Riemannian metric on the space of arrows. This is equivalent to the existence of a Riemannian metric on $\Pi(A)$.

The existence of a Riemannian metric on a Lie groupoid $\mathcal{G} \rightrightarrows M$ is equivalent to the existence of a splitting of the exact sequence of vector

bundles

$$\text{Ker } dt \hookrightarrow T\mathcal{G} \rightarrow \mathfrak{t}^*TM.$$

Example 14.74 gives a Poisson manifold whose cotangent bundle is integrable, but not Riemannian integrable. That example builds on the following example of a non-Hausdorff Lie groupoid with no Riemannian structure.

Example 13.93. The first bundle of Lie groups from Example 13.82 carries a Riemannian metric. However, this can be destroyed by a simple modification. Consider the quotient

$$\mathcal{G} = (\mathbb{R} \times \mathbb{R})/\Lambda, \quad \Lambda_t = \begin{cases} \mathbb{Z}, & t < 0, \\ 0, & t = 0, \\ (1+t)\mathbb{Z}, & t > 0. \end{cases}$$

To prove that the manifold \mathcal{G} does not admit a Riemannian metric, it suffices to show that there exists no vector field on \mathcal{G} which projects to $\frac{\partial}{\partial t}$. Assume such a vector field exists. Since the projection $\mathbb{R} \times \mathbb{R} \rightarrow \mathcal{G}$ is a local diffeomorphism, we can lift X to a vector field $\hat{X} = \frac{\partial}{\partial t} + f(t, \xi) \frac{\partial}{\partial \xi}$ which is invariant under translation by local sections of Λ . The invariance condition means that, if $\sigma(t) = (t, s(t))$ is a local section of Λ , then

$$f(t, \xi + s(t)) = f(t, \xi) + \frac{\partial s}{\partial t}(t).$$

Applying this to $s(t) = 1$, we obtain for $t < 0$

$$f(t, \xi + 1) = f(t, \xi).$$

Applying invariance to $s(t) = 1 + t$, we obtain for $t > 0$

$$f(t, \xi + 1 + t) = f(t, \xi) + 1.$$

By taking the limit $t = 0$ in these equalities, we obtain a contradiction.

Later we will use this example to build a Lie algebroid A which is integrable, but none of its integrations admit a Riemannian metric. 

We will also consider actions of a Lie groupoid $\mathcal{G} \rightrightarrows M$ on non-Hausdorff manifolds $\mu : S \rightarrow M$. Of course, the associated action groupoid $\mathcal{G} \times S \rightrightarrows S$ is still a ‘‘Lie groupoid’’, but it violates our conventions: the base is non-Hausdorff. Nevertheless, the orbits of the action are still Hausdorff and the restrictions to these orbits provides a partition of $\mathcal{G} \times S \rightrightarrows S$ into Hausdorff Lie subgroupoids.

We have already encountered a similar phenomenon in Lemma 13.88. The homotopy groupoid of a foliation with Hausdorff leaves may fail to be a Lie groupoid in the sense of Convention 13.91, because the base manifold may be non-Hausdorff.

There are simple criteria to decide when a Lie groupoid is Hausdorff:

Proposition 13.94. *For a Lie groupoid $\mathcal{G} \rightrightarrows M$, the following are equivalent:*

- (i) \mathcal{G} is Hausdorff.
- (ii) The unit section $\mathbf{u}(M)$ is closed in \mathcal{G} .
- (iii) For every $x \in M$, any $g \in \mathcal{G}_x$ can be separated from 1_x .

Proof. (i) \Rightarrow (ii). Consider a convergent sequence $1_{x_n} \rightarrow g$. We check that g is a unit. Since \mathbf{t} is continuous, we have

$$x := \mathbf{t}(g) = \mathbf{t}(\lim 1_{x_n}) = \lim x_n.$$

Since $\mathbf{u} : M \rightarrow \mathcal{G}$ is continuous and \mathcal{G} is Hausdorff, we conclude that

$$1_x = \mathbf{u}(x) = \mathbf{u}(\lim x_n) = \lim 1_{x_n} = g.$$

(ii) \Rightarrow (iii). Assume that $g \in \mathcal{G}_x$ cannot be separated from 1_x . Let U and V be charts centered at 1_x and at g , and let $B_n(1_x)$ and $B_n(g)$ be open balls of radius $1/n$ in these charts. Since g and 1_x cannot be separated there exists $g_n \in B_n(1_x) \cap B_n(g)$ with $g_n \rightarrow 1_x$ and $g_n \rightarrow g$. Then, using continuity of multiplication and inverse, we find that

$$1_{\mathbf{t}(g_n)} = g_n g_n^{-1} \rightarrow g(1_x)^{-1} = g.$$

This contradicts (ii).

(iii) \Rightarrow (i). Let $g, h \in \mathcal{G}$, with $g \neq h$. If $\mathbf{t}(g) \neq \mathbf{t}(h)$, then we choose nonintersecting opens $U, V \subset M$ such that $\mathbf{t}(g) \in U$ and $\mathbf{t}(h) \in V$. The open sets $\mathbf{t}^{-1}(U)$ and $\mathbf{t}^{-1}(V)$ separate g and h . Similarly, if $\mathbf{s}(g) \neq \mathbf{s}(h)$, then g and h can be separated. So we can assume $g, h \in \mathcal{G}$ have the same source and target. If g and h cannot be separated, then we can find a sequence k_n converging to both g and h . The sequence of units $1_{\mathbf{t}(k_n)} := k_n k_n^{-1}$ converges to both $gh^{-1} \in \mathcal{G}_{\mathbf{t}(g)}$ and to $1_{\mathbf{t}(g)}$, contradicting (iii). \square

Proof of Proposition 13.90. Since M is Hausdorff, it suffices to show that any fiber of the map $\mathbf{s} : \mathbf{t}^{-1}(x) \rightarrow M$ is contained in a Hausdorff open set.

First we show that the isotropy group $\mathcal{G}_x = \mathbf{t}^{-1}(x) \cap \mathbf{s}^{-1}(x)$ is Hausdorff. By using translations, it suffices to show that any $g \in \mathcal{G}_x$ with $g \neq 1_x$ can be separated from 1_x . Since \mathcal{G} is a manifold, we can find an open set $U \subset \mathcal{G}_x$ such that $1_x \in U$ and $g \notin U$. Since \mathcal{G}_x is a topological group, the division map $\mathbf{d} : \mathcal{G}_x \times \mathcal{G}_x \rightarrow \mathcal{G}_x$, $(g_1, g_2) \mapsto g_1 g_2^{-1}$ is continuous for the product topology on $\mathcal{G}_x \times \mathcal{G}_x$. Therefore, there exists an open set $O \subset \mathcal{G}_x$ such that $\mathbf{d}(O \times O) \subset U$. Then O and $L_g(O)$ separate 1_x and g . Otherwise if $g_1 = g g_2$, with $g_1, g_2 \in O$, we obtain a contradiction: $g = g_1 g_2^{-1} \in U$.

Next we observe that $\mathbf{s} : \mathfrak{t}^{-1}(x) \rightarrow M$ is a constant rank map. For this, note that for any $h_1, h_2 \in \mathfrak{t}^{-1}(x)$ we can find a local bisection

$$b : O \rightarrow \mathcal{G}, \quad \mathfrak{t} \circ b = \text{Id}_O, \quad \text{such that} \quad b(\mathbf{s}(h_1)) = h_1^{-1}h_2.$$

Consider the induced right translation

$$R_b : \mathbf{s}^{-1}(O) \rightarrow \mathbf{s}^{-1}(O'), \quad R_b(h) = hb(\mathbf{s}(h)),$$

where $O' = \mathbf{s} \circ b(O)$. This map sends h_1 to h_2 , maps source fibers diffeomorphically to source fibers, and preserves target fibers. Thus, $\mathbf{s} : \mathfrak{t}^{-1}(x) \rightarrow M$ has constant rank.

By the local normal form theorem for constant rank maps, we obtain the following:

- All the fibers of $\mathbf{s} : \mathfrak{t}^{-1}(x) \rightarrow M$ are embedded submanifolds of $\mathfrak{t}^{-1}(x)$. In particular, $\mathcal{G}_x = \mathfrak{t}^{-1}(x) \cap \mathbf{s}^{-1}(x)$ is a Lie group.

- Any $h \in \mathfrak{t}^{-1}(x)$ has an open neighborhood $U \subset \mathfrak{t}^{-1}(x)$ such that $V := \mathbf{s}(U)$ is an embedded submanifold of M , over which \mathbf{s} admits a local section $\sigma : V \rightarrow U$.

Note that $\mathbf{s}^{-1}(V)$ is open in $\mathfrak{t}^{-1}(x)$, because

$$\mathbf{s}^{-1}(V) = \bigcup_{g \in \mathcal{G}_x} L_g(U).$$

Finally, we have a diffeomorphism

$$\psi : \mathcal{G}_x \times V \xrightarrow{\sim} \mathbf{s}^{-1}(V) \subset \mathfrak{t}^{-1}(x), \quad (g, y) \mapsto g\sigma(y),$$

with inverse is given by

$$\psi^{-1}(h) = (h\sigma(\mathbf{s}(h)))^{-1}, \mathbf{s}(h).$$

In particular, this show that $\mathbf{s}^{-1}(V)$ is a Hausdorff open subset of $\mathfrak{t}^{-1}(x)$. \square

We now turn to symplectic realizations $\mu : (S, \omega) \rightarrow (M, \pi)$ where S is not necessarily Hausdorff. In this case, the following still hold:

- Libermann’s Theorem, Theorem 6.27 — though each argument in the proof has to be replaced by its local version,
- Propositions 6.32, 12.3, and 12.6 and Corollary 12.5.

In particular, Proposition 12.3 gives the associated **infinitesimal action**

$$\mathfrak{a} : \mu^*T^*M \rightarrow TS.$$

Hence, we still have the orbit distribution $\mathfrak{a}(\mu^*T^*M) \subset TS$ and this is an involutive distribution in the sense discussed above. By Proposition 12.6, its leaves, i.e., the orbits, are included in preimages of symplectic leaves.

Definition 13.95. A symplectic realization $\mu : (S, \omega) \rightarrow (M, \pi)$ is of **Hausdorff type** if for every symplectic leaf L of (M, π) the preimage $\mu^{-1}(L)$ is Hausdorff.

Note that for a symplectic realization of Hausdorff type both the fibers and the orbits are Hausdorff. This condition allows us to talk about completeness of Hamiltonian vector fields of type $X_{H \circ \mu}$ — since they are tangent to orbits — and mimic Definition 12.1 to define completeness of the realization. Therefore our convention for symplectic realizations is the following:

Convention 13.96. For a symplectic realization $\mu : (S, \omega) \rightarrow (M, \pi)$:

- The total space S may be non-Hausdorff.
- The base is a Hausdorff manifold.

A **complete symplectic realization** is a Hausdorff-type symplectic realization for which $X_{H \circ \mu}$ is a complete vector field whenever X_H is complete.

Under the same assumption of Hausdorff type, the following results remain valid without any changes:

- Existence of maximal lifts from Proposition 12.18 and the characterization of completeness from Theorem 12.22.
- Parallel transport is invariant under cotangent path-homotopy: Theorem 12.24 and Corollary 12.26.

Actually, a closer inspection of the proofs of these results will show that only the Hausdorffness of the orbits is used. However, our assumption of Hausdorff type ensures that exactly the same proofs work.

Example 13.97. Non-Hausdorff symplectic realizations can be easily constructed by starting with any Hausdorff one $\mu : (S, \omega) \rightarrow (M, \pi)$ and taking the product with another, possibly non-Hausdorff, symplectic manifold S_0 . Of course, this produces examples which are not of Hausdorff type.

Here are some simple examples of non-Hausdorff symplectic realizations. Start with the plane with the double line from Example 13.85, $P = (\mathbb{R} \cup_{\mathbb{R}^*} \mathbb{R}) \times \mathbb{R}$. The projection to \mathbb{R}^2 provides local coordinates (x, y) on each of the two sheets. Define

$$S := P \times \mathbb{R}^2, \quad \omega := dx \wedge d\bar{x} + dy \wedge d\bar{y}.$$

On S consider the two foliations

$$T\mathcal{F} = \text{Span} \left\langle \frac{\partial}{\partial \bar{x}} \right\rangle, \quad T\mathcal{F}^\perp = \text{Span} \left\langle \frac{\partial}{\partial y}, \frac{\partial}{\partial \bar{x}}, \frac{\partial}{\partial \bar{y}} \right\rangle.$$

They have Hausdorff leaves and they are symplectic orthogonal to each other. We end up with two symplectic realizations of Hausdorff type, which

are in fact complete:

$$\begin{aligned} \mu : (S, \omega) &\rightarrow \left(\mathbb{R}^3, \frac{\partial}{\partial \bar{y}} \wedge \frac{\partial}{\partial y} \right), & \mu(x, y, \bar{x}, \bar{y}) &= (x, y, \bar{y}), \\ \mu^\perp : (S, \omega) &\rightarrow (\mathbb{R}, 0), & \mu^\perp(x, y, \bar{x}, \bar{y}) &= x. \end{aligned}$$

Note that the presence of the double line is also reflected in the topology of the fibers: for both maps, the fiber above $x = 0$ has two connected components, while all the other fibers are connected.

Exercise 13.98. With the same (S, ω) as above, show that the symplectic realization

$$\mu : (S, \omega) \rightarrow \left(\mathbb{R}^3, \frac{\partial}{\partial \bar{y}} \wedge \frac{\partial}{\partial y} \right), \quad \mu(x, y, \bar{x}, \bar{y}) = (y, \bar{x}, \bar{y})$$

is not of Hausdorff type. Exhibit a cotangent path for which the parallel transport map is not well-defined. 

Problems

13.1. Describe the groupoid of the flow of a *time-dependent* vector field X .

13.2. Let $R : TM \rightarrow TM$ be an endomorphism with vanishing Nijenhuis torsion; i.e., for all $X, Y \in \mathfrak{X}(M)$ we have

$$[R(X), R(Y)] - R([R(X), Y]) - R([X, R(Y)]) + R^2([X, Y]) = 0.$$

Show that the bilinear operation on vector fields given by

$$[X, Y]_R := [R(X), Y] + [X, R(Y)] - R([X, Y])$$

defines a Lie algebroid structure on $A = TM$ with anchor $\rho = R$.

13.3. Consider the Möbius band $M = (\mathbb{S}^1 \times \mathbb{R}) / \mathbb{Z}_2$, where \mathbb{Z}_2 acts by $(\theta, t) \mapsto (\theta + \pi, -t)$ and the foliation \mathcal{F} of M acts by circles $t = \pm c$.

- (a) Show that the relation groupoid $\text{Rel}(\mathcal{F}) \rightrightarrows M$ associated with the foliation \mathcal{F} is not a Lie subgroupoid of the pair groupoid $M \times M \rightrightarrows M$.
- (b) Describe the holonomy groupoid $\text{Hol}(M, \mathcal{F}) \rightrightarrows M$ as a smooth manifold together with its groupoid structure.

13.4. Let $\mathcal{G} \rightrightarrows M$ be a Lie groupoid with possibly disconnected source/target fibers and units. Denote by $\mathcal{G}^0 \subset \mathcal{G}$ the union of all the connected components of the \mathfrak{t} -fibers containing the units.

- (a) Verify that \mathcal{G}^0 is an open set in \mathcal{G} which is invariant under inversion, so it coincides with the union of all the connected components of the \mathfrak{s} -fibers containing the units.

- (b) Show that \mathcal{G}^0 is a Lie subgroupoid of \mathcal{G} , so in particular they have the same Lie algebroid.
- (c) Give an example of a Lie groupoid $\mathcal{G} \rightrightarrows M$ with connected space of arrows \mathcal{G} and connected space of units M , but with disconnected \mathfrak{t} -fibers.

One calls \mathcal{G}^0 the \mathfrak{t} -connected component of the identity of \mathcal{G} . Note that by (c) this does not coincide with the connected component of the space \mathcal{G} containing the units.

13.5. Let $A \rightarrow M$ be a Lie algebroid, let $N \subset M$ be a submanifold, and consider the “restriction”

$$A_N := \{a \in A : \rho(a) \in TN\}.$$

Prove the following:

- (a) If A_N is a vector subbundle of $A|_N$, then it is a subalgebroid of A .
- (b) If $\mathcal{G} \rightrightarrows M$ is an integration of A and the restriction $\mathcal{G}|_N$ is a Lie subgroupoid of \mathcal{G} , then (a) holds and A_N is the Lie algebroid of $\mathcal{G}|_N$.

13.6. Consider a proper Lagrangian fibration $\mu : (S, \omega) \rightarrow M$ with associated lattice Λ and torus bundle \mathcal{T}_Λ . Show the following:

- (a) \mathcal{T}_Λ is a Lie groupoid with Lie algebroid isomorphic to T^*M with zero anchor and zero Lie bracket.
- (b) The action of \mathcal{T}_Λ on S is a Lie groupoid action and the corresponding infinitesimal action is precisely the infinitesimal action $\mathfrak{e} : \mu^*T^*M \rightarrow TS$ associated to the symplectic realization.

13.7. Let G be a Lie group acting on a manifold M and form its action groupoid $G \times M \rightrightarrows M$. Show that an action of $G \times M \rightrightarrows M$ on a smooth map $\mu : S \rightarrow M$ is the same thing as an action of the Lie group G on S together with a G -equivariant map $\mu : S \rightarrow M$.

13.8. An action of a Lie groupoid $\mathcal{G} \rightrightarrows M$ on a vector bundle $p : E \rightarrow M$ is called a linear action if the action of each arrow $g \in \mathcal{G}$ is a linear map

$$g : E_{s(g)} \rightarrow E_{t(g)}, \quad u \mapsto gu.$$

Show that a linear action is the same thing as a Lie groupoid morphism

$$\Phi : \mathcal{G} \rightarrow \mathrm{GL}(E)$$

covering the identity map. For this reason, a linear action of \mathcal{G} is also called a **representation** of \mathcal{G} .

13.9. A **linear action** of a Lie algebroid A on a vector bundle $p : E \rightarrow M$ is an action $\mathfrak{a} : \Gamma(A) \rightarrow \mathfrak{X}_{\text{lin}}(E)$. Show the following:

- (a) Linear actions on E can be identified with Lie algebroid morphisms $\phi : A \rightarrow \mathfrak{gl}(E)$ covering the identity map.
- (b) Linear actions on E can be identified with flat A -connections ∇ on E .

For this reason, a flat A -connection is often called a **representation** of A .

13.10. Let (M, π) be a Poisson manifold, and let $p : E \rightarrow M$ be a vector bundle.

- (a) Show that the parallel transport with respect to a flat contravariant connection ∇ yields an action of $\Pi(M, \pi)$ on E by linear isomorphisms of the fibers, i.e., a representation of $\Pi(M, \pi)$.
- (b) Show that flat contravariant connections on E can be interpreted as algebroid morphisms $T^*M \rightarrow \mathfrak{gl}(E)$ covering the identity map, i.e., representations of T^*M .
- (c) What is the relationship between the first two items and Lie's Theorems?

13.11. Let P be a manifold endowed with a free and proper action of a Lie group G . Recall that the lifted action of G on T^*P is Hamiltonian; hence $M := T^*P/G$ carries a quotient Poisson structure π . Shows that (M, π) is of type (A^*, π_A) for some Lie algebroid A .

HINT: Atiyah Lie algebroid.

13.12. Let A be a Lie algebroid, and consider the fiberwise linear Poisson structure (A^*, π_A) . Show the following:

- (a) The symplectic leaves of π_A are all of the form $(T^*\mathcal{O}, \omega_{\text{can}})$ if and only if the anchor is injective.
- (b) π_A is regular if and only if A is a regular Lie algebroid and all isotropy Lie algebras are abelian.

13.13. Let $\mathcal{G} \rightrightarrows M$ be a Lie groupoid. Define a **bisection** of $\mathcal{G} \rightrightarrows M$ to be a smooth map $b : M \rightarrow \mathcal{G}$ such that $\mathbf{t} \circ b = \text{Id}$ and $\mathbf{s} \circ b : M \rightarrow M$ is a diffeomorphism. Denote by $\Gamma(\mathcal{G})$ the set of bisections. Show the following:

- (a) For $b_1, b_2 \in \Gamma(\mathcal{G})$ one has a bisection $b_1 \star b_2 \in \Gamma(\mathcal{G})$ defined by

$$(b_1 \star b_2)(x) := b_1(x) \cdot b_2(\mathbf{s} \circ b_1(x)).$$

- (b) $(\Gamma(\mathcal{G}), \star)$ is a group.
- (c) For each $b \in \Gamma(\mathcal{G})$ the conjugation by b defined by

$$\Psi_b(g) := b(\mathbf{t}(g))^{-1} \cdot g \cdot b(\mathbf{s}(g))$$

is a Lie groupoid automorphism. Moreover, $\Psi : \Gamma(\mathcal{G}) \rightarrow \text{Aut}(\mathcal{G})$ is a group antimorphism.

13.14. Let $\mathcal{G} \rightrightarrows M$ be a Lie groupoid with Lie algebroid $A \rightarrow M$. For a complete section $\alpha \in \Gamma(A)$ — see Proposition 13.37 — define the bisection

$$\exp(\alpha) : M \rightarrow \mathcal{G}, \quad \exp(\alpha)(x) := \phi_{\alpha}^1(\mathbf{u}(x)).$$

We call $\exp : \Gamma_{\text{cpl}}(A) \rightarrow \Gamma(\mathcal{G})$ the **exponential map** of $\mathcal{G} \rightrightarrows M$. Fix a complete section α and show the following (see the previous problem for notation):

(a) We have a group homomorphism

$$(\mathbb{R}, +) \rightarrow (\Gamma(\mathcal{G}), \star), \quad t \mapsto \exp(t\alpha).$$

(b) For each $t \in \mathbb{R}$, the Lie groupoid automorphism

$$\Phi_{\alpha}^t : \mathcal{G} \rightarrow \mathcal{G}, \quad \Phi_{\alpha}^t := \Psi_{\exp(t\alpha)},$$

is an integration of the flow of the section $\phi_{\alpha}^t : A \rightarrow A$, defined in Problem 9.18.

13.15. Let G be a Lie group with Lie algebra \mathfrak{g} , and let $\theta_G \in \Omega^1(G, \mathfrak{g})$ be the Maurer-Cartan form of G . Given a Maurer-Cartan form $\theta \in \Omega^1(M, \mathfrak{g})$ — see Definition 6.21 — on a 1-connected manifold M show that there is a map $f : M \rightarrow G$ such that

$$\theta = f^*\theta_G.$$

Moreover, show that f is unique up to a left-translation by an element of G . What happens if M is not 1-connected?

HINT: Lie's Second Theorem and the homotopy groupoid of M .

Symplectic Groupoids

In the previous chapter, we have seen that a Lie groupoid has an associated Lie algebroid. We will now look at groupoids whose associated Lie algebroid is isomorphic to the cotangent Lie algebroid of a Poisson structure. These should be thought of as the group-like objects “integrating” Poisson brackets. It turns out that they are characterized by the presence of a symplectic structure on the space of arrows compatible with the multiplication.

14.1. Symplectic groupoids and Poisson structures

In order to introduce the notion of symplectic groupoid, we first discuss “compatibility” between a differential form and the groupoid structure.

Let $\mathcal{G} \rightrightarrows M$ be a Lie groupoid, and first consider a degree 0 form, i.e., a function $f \in C^\infty(\mathcal{G})$. Then the compatibility condition is the obvious one: the function must be a homomorphism of groupoids $f : (\mathcal{G}, \cdot) \rightarrow (\mathbb{R}, +)$:

$$f(g \cdot h) = f(g) + f(h) \quad \forall (g, h) \in \mathcal{G}^{(2)}.$$

We can interpret this equation as an equality of 0-forms on $\mathcal{G}^{(2)}$ as follows. Consider the multiplication map and the projections

$$\mathbf{m}, \text{pr}_1, \text{pr}_2 : \mathcal{G}^{(2)} \rightarrow \mathcal{G}.$$

Then the compatibility equation can be written as

$$\mathbf{m}^* f = \text{pr}_1^* f + \text{pr}_2^* f,$$

and this now makes sense for forms of arbitrary degree.

Definition 14.1. A **multiplicative form** on a Lie groupoid \mathcal{G} is a differential form $\omega \in \Omega^k(\mathcal{G})$ satisfying

$$\mathbf{m}^*\omega = \text{pr}_1^*\omega + \text{pr}_2^*\omega.$$

A groupoid may or may not carry many such forms, depending on its structure.

Exercise 14.2. Show that on a Lie group G :

- (a) A 1-form on G is multiplicative if and only if it is bi-invariant.
- (b) For $k \geq 2$, all multiplicative k -forms on G vanish identically.

The following useful lemma gives some insight into the multiplicativity condition.

Lemma 14.3. For $k \geq 1$, let $\omega \in \Omega^k(\mathcal{G})$ be a multiplicative form. The restriction of ω to the \mathbf{s} -fibers (respectively, \mathbf{t} -fibers) is a right-invariant (respectively, left-invariant) foliated form

$$(\text{d}_g R_h)^*\omega|_{\text{Ker d}_{gh}\mathbf{s}} = \omega|_{\text{Ker d}_g\mathbf{s}}, \quad (\text{d}_h L_g)^*\omega|_{\text{Ker d}_{gh}\mathbf{t}} = \omega|_{\text{Ker d}_h\mathbf{t}}.$$

Proof. Note that

$$\text{d}_g R_h(v) = \text{d}_{(g,h)}\mathbf{m}(v, 0_h), \quad \forall v \in \text{Ker}(\text{d}_g\mathbf{s}), \quad \mathbf{s}(g) = \mathbf{t}(h).$$

Therefore, using multiplicativity of ω ,

$$\omega(\text{d}_g R_h(v_1), \dots, \text{d}_g R_h(v_k)) = \omega(v_1, \dots, v_k).$$

Similarly for the second equation. □

It is also instructive to realize that multiplicativity may be seen as a cohomological condition. Namely, we have a map

$$\delta : \Omega^k(\mathcal{G}) \rightarrow \Omega^k(\mathcal{G}^{(2)}), \quad \delta\omega := \text{pr}_1^*\omega - \mathbf{m}^*\omega + \text{pr}_2^*\omega,$$

which is preceded by a similar map

$$\delta : \Omega^k(M) \rightarrow \Omega^k(\mathcal{G}), \quad \delta\alpha := \mathbf{s}^*\alpha - \mathbf{t}^*\alpha.$$

A simple computation shows that $\delta \circ \delta = 0$. The condition that $\omega \in \Omega^k(\mathcal{G})$ is multiplicative now means that ω is a cocycle:

$$\delta\omega = 0.$$

One has the “obvious” cocycles, namely the boundaries

$$\omega = \delta(\alpha) = \mathbf{s}^*\alpha - \mathbf{t}^*\alpha \quad (\alpha \in \Omega^{k-1}(M)).$$

A form ω of this type is called a **multiplicatively exact form**.

We can now introduce symplectic groupoids. We will use the symbol $\Sigma \rightrightarrows M$ to distinguish symplectic groupoids from arbitrary Lie groupoids.

Definition 14.4. A **symplectic groupoid** is a Lie groupoid $\Sigma \rightrightarrows M$ together with a multiplicative symplectic form $\Omega \in \Omega^2(\Sigma)$.

Example 14.5. Let (M, ω) be a symplectic manifold and consider the pair groupoid $\Sigma := M \times M \rightrightarrows M$ — see Example 13.10 — with the symplectic form

$$\Omega := \text{pr}_1^* \omega - \text{pr}_2^* \omega = -\delta\omega \in \Omega^2(M \times M).$$

This form is clearly multiplicative and symplectic. Hence,

$$(M \times M, \Omega) \rightrightarrows M$$

is a symplectic groupoid. 

Example 14.6. Let $\Sigma = T^*M$ be the cotangent bundle of any manifold M , endowed with the canonical symplectic form $\Omega = \omega_{\text{can}}$. Addition on the fibers makes T^*M into a bundle of abelian Lie groups over M , which is actually a symplectic groupoid:

$$(T^*M, \omega_{\text{can}}) \rightrightarrows M.$$

The multiplicativity of ω_{can} follows from that of the Liouville 1-form θ_L . For that, note that the space of composable arrows is $\Sigma^{(2)} = T^*M \oplus T^*M$ and then multiplication is given by

$$\mathbf{m} : T^*M \oplus T^*M \rightarrow T^*M, \quad (\alpha, \beta) \mapsto \alpha + \beta.$$

If $(v_1, v_2) \in T_{(\alpha, \beta)}(T^*M \oplus T^*M)$, then $d \text{pr}(v_1) = d \text{pr}(v_2) = v \in TM$, so

$$\begin{aligned} \theta_L(d\mathbf{m}(v_1, v_2)) &= (\alpha + \beta)(v) \\ &= \alpha(v) + \beta(v) \\ &= \theta_L(d \text{pr}_1(v_1, v_2)) + \theta_L(d \text{pr}_2(v_1, v_2)). \end{aligned}$$

Therefore $\delta\theta_L = 0$, so θ_L is indeed multiplicative.

For any integrable lattice $\Lambda \subset T^*M$, we have seen that ω_{can} descends to a symplectic form ω_Λ on $\mathcal{T}_\Lambda := T^*M/\Lambda$, which makes

$$(\mathcal{T}_\Lambda, \omega_\Lambda) \rightrightarrows M$$

into a symplectic groupoid. Multiplicativity of ω_Λ follows because the quotient map is a groupoid morphism or, alternatively, by applying Proposition 12.30 to $S = \mathcal{T}_\Lambda$. 

Example 14.7. Let G be a Lie group, and let $\Sigma = G \ltimes \mathfrak{g}^* \rightrightarrows \mathfrak{g}^*$ be the action groupoid associated with the coadjoint action — see Example 13.13. Using the isomorphism $l : T^*G \simeq G \times \mathfrak{g}^*$ induced by left translation — see (6.15) — we consider the symplectic form

$$\Omega := -l_*\omega_{\text{can}} = d(l_*\theta_L) \in \Omega^2(G \ltimes \mathfrak{g}^*).$$

The choice of the minus sign will be clear soon. We claim that Ω is multiplicative, so that

$$(G \times \mathfrak{g}^*, \Omega) \rightrightarrows \mathfrak{g}^*$$

is a symplectic groupoid.

For this we show that $\theta := l_*(\theta_L) \in \Omega^1(G \times \mathfrak{g}^*)$ is multiplicative. This form was computed explicitly in (6.17):

$$\theta : T_{(g,\xi)}(G \times \mathfrak{g}^*) \rightarrow \mathbb{R}, \quad (v_g, \eta) \mapsto \langle \xi, dL_{g^{-1}}(v_g) \rangle.$$

We identify $\Sigma^{(2)} = G \times G \times \mathfrak{g}^*$:

$$((g, \eta), (h, \xi)) \leftrightarrow (g, h, \xi), \quad \text{where } \eta = \text{Ad}_h^* \xi.$$

Then we have

$$\mathbf{m}(g, h, \xi) = (gh, \xi), \quad \text{pr}_1(g, h, \xi) = (g, \text{Ad}_h^* \xi), \quad \text{pr}_2(g, h, \xi) = (h, \xi),$$

and it follows that

$$\begin{aligned} \mathbf{m}^* \theta_{(g,h,\xi)}(v, w, \eta) &= \langle \xi, dL_{(gh)^{-1}}(dR_h v + dL_g w) \rangle \\ &= \langle \xi, \text{Ad}_{h^{-1}}(dL_{g^{-1}} v) + dL_{h^{-1}} w \rangle, \\ \text{pr}_1^* \theta_{(g,h,\xi)}(v, w, \eta) &= \langle \text{Ad}_h^* \xi, dL_{g^{-1}} v \rangle, \\ \text{pr}_2^* \theta_{(g,h,\xi)}(v, w, \eta) &= \langle \xi, dL_{h^{-1}} w \rangle. \end{aligned}$$

We obtain that θ is multiplicative, as claimed. 

There is also a more geometric interpretation of the multiplicativity condition.

Lemma 14.8. *A form $\Omega \in \Omega^2(\Sigma)$ on a Lie groupoid $\Sigma \rightrightarrows M$ is multiplicative if and only if the graph of the multiplication,*

$$\text{Graph}(\mathbf{m}) = \{(g, h, g \cdot h) : (g, h) \in \Sigma^{(2)}\} \subset \Sigma \times \Sigma \times \Sigma,$$

is isotropic in $(\Sigma, \Omega) \times (\Sigma, \Omega) \times (\Sigma, -\Omega)$.

Proof. Note that $\text{Graph}(\mathbf{m})$ is the image of the immersion

$$\phi : \Sigma^{(2)} \rightarrow \Sigma \times \Sigma \times \Sigma, \quad (g, h) \mapsto (\text{pr}_1(g, h), \text{pr}_2(g, h), \mathbf{m}(g, h))$$

and that

$$\phi^*(\text{pr}_1^* \Omega + \text{pr}_2^* \Omega - \text{pr}_3^* \Omega) = \text{pr}_1^* \omega + \text{pr}_2^* \omega - \mathbf{m}^* \omega.$$

Hence, the lemma follows. □

Next we discuss the basic properties of symplectic groupoids.

Proposition 14.9. *A symplectic form $\Omega \in \Omega^2(\Sigma)$ on a Lie groupoid $\Sigma \rightrightarrows M$ is multiplicative if and only if*

$$\text{Graph}(\mathbf{m}) \subset (\Sigma, \Omega) \times (\Sigma, \Omega) \times (\Sigma, -\Omega)$$

is a Lagrangian submanifold.

Moreover, any symplectic groupoid (Σ, Ω) has the following properties:

(i) *The \mathbf{t} -fibers and \mathbf{s} -fibers are symplectic orthogonal:*

$$(\text{Ker } d\mathbf{t})^{\perp\Omega} = \text{Ker } d\mathbf{s}.$$

(ii) *The unit section $\mathbf{u} : M \hookrightarrow \Sigma$ is a Lagrangian embedding:*

$$(TM)^{\perp\Omega} = TM.$$

(iii) *The inversion map $\iota : \Sigma \rightarrow \Sigma$ is antisymplectic:*

$$\iota^*\Omega = -\Omega.$$

In particular, $\dim \Sigma = 2 \dim M$.

Proof. If the graph of \mathbf{m} is Lagrangian, the previous lemma shows that Ω is multiplicative. Conversely, assume that (Σ, Ω) is a symplectic groupoid. We will see that $\dim \Sigma = 2 \dim M$, and hence

$$\dim(\text{Graph}(\mathbf{m})) = 2 \dim \Sigma - \dim M = 3 \dim M = \frac{1}{2} \dim(\Sigma \times \Sigma \times \Sigma).$$

So, again by the lemma, the graph is Lagrangian.

We start by observing that $\mathbf{u}^*\Omega = 0$. For this, we pull back the multiplicativity condition along the map $\tilde{\mathbf{u}} : M \rightarrow \Sigma^{(2)}$, $x \mapsto (\mathbf{u}(x), \mathbf{u}(x))$:

$$\begin{aligned} 0 &= \tilde{\mathbf{u}}^*\delta\Omega = \tilde{\mathbf{u}}^*\text{pr}_1^*\Omega - \tilde{\mathbf{u}}^*\mathbf{m}^*\Omega + \tilde{\mathbf{u}}^*\text{pr}_2^*\Omega \\ &= (\text{pr}_1 \circ \tilde{\mathbf{u}})^*\Omega - (\mathbf{m} \circ \tilde{\mathbf{u}})^*\Omega + (\text{pr}_2 \circ \tilde{\mathbf{u}})^*\Omega \\ &= \mathbf{u}^*\Omega - \mathbf{u}^*\Omega + \mathbf{u}^*\Omega = \mathbf{u}^*\Omega. \end{aligned}$$

Next, to show that inversion is an antisymplectomorphism, consider

$$\Delta : \Sigma \rightarrow \Sigma^{(2)}, \quad g \mapsto (g, g^{-1})$$

and observe that

$$\mathbf{u} \circ \mathbf{t} = \mathbf{m} \circ \Delta, \quad \text{pr}_1 \circ \Delta = \text{Id}, \quad \text{pr}_2 \circ \Delta = \iota.$$

Pulling back the multiplicativity condition along Δ and using that $\mathbf{u}^*\Omega = 0$, we obtain

$$0 = \mathbf{t}^*\mathbf{u}^*\Omega = \Delta^*\mathbf{m}^*\Omega = \Delta^*(\text{pr}_1^*\Omega + \text{pr}_2^*\Omega) = \Omega + \iota^*\Omega.$$

Now, recalling that the fixed point set of an antisymplectomorphism is a coisotropic submanifold, we see that the unit section is both coisotropic and isotropic. Hence it is Lagrangian and, in particular, we have

$$\dim \Sigma = 2 \dim M.$$

Finally, we claim that source and target fibers are Ω -orthogonal. Since we already know they have dimension equal to $\dim M = 1/2 \dim \Sigma$ it is enough to check that

$$\Omega(v, w) = 0, \quad \forall v \in \text{Ker } d_g \mathbf{s}, w \in \text{Ker } d_g \mathbf{t}.$$

For that we observe the following:

(i) If $v \in \text{Ker } d_g \mathbf{s}$, then

$$(v, 0_{1_{\mathbf{s}(g)}}) \in T_{(g, 1_{\mathbf{s}(g)})} \Sigma^{(2)} \quad \text{and} \quad v = \mathbf{dm}(v, 0_{1_{\mathbf{s}(g)}}).$$

(ii) If $w \in \text{Ker } d_g \mathbf{t}$, then $w_0 := dL_{g^{-1}} w \in \text{Ker } d_{1_{\mathbf{s}(g)}} \mathbf{t}$ satisfies

$$(0_g, w_0) \in T_{(g, 1_{\mathbf{s}(g)})} \Sigma^{(2)} \quad \text{and} \quad w = \mathbf{dm}(0_g, w_0).$$

Therefore, using the multiplicativity of Ω , we obtain

$$\begin{aligned} \Omega(v, w) &= \Omega(\mathbf{dm}(v, 0_{1_{\mathbf{s}(g)}}), \mathbf{dm}(0_g, w_0)) \\ &= \Omega(d \text{pr}_1(v, 0_{1_{\mathbf{s}(g)}}), d \text{pr}_1(0_g, w_0)) + \Omega(d \text{pr}_2(v, 0_{1_{\mathbf{s}(g)}}), d \text{pr}_2(0_g, w_0)) \\ &= \Omega(v, 0_g) + \Omega(0_{1_{\mathbf{s}(g)}}, w_0) = 0. \end{aligned} \quad \square$$

Finally we explain the connection between symplectic groupoids and Poisson structures. Recalling Libermann’s Theorem, property (i) in the previous proposition already shows the existence of a Poisson structure on the base of a symplectic groupoid.

Theorem 14.10. *Let $(\Sigma, \Omega) \rightrightarrows M$ be a symplectic groupoid. There exists a unique Poisson structure π on M such that the target map is Poisson:*

$$\mathbf{t} : (\Sigma, \Omega) \rightarrow (M, \pi).$$

Moreover:

- (i) \mathbf{t} is a complete symplectic realization.
- (ii) The symplectic leaves of (M, π) are the connected components of the orbits of Σ .
- (iii) There is a canonical Lie algebroid isomorphism

$$(14.1) \quad \sigma_\Omega : \text{Lie}(\Sigma) \rightarrow T^*M, \quad \alpha \mapsto -\mathbf{u}^*(i_\alpha \Omega).$$

In particular $\pi^\# = \rho \circ \sigma_\Omega^{-1}$, where ρ is the anchor of $\text{Lie}(\Sigma)$.

Proof. We can apply Liberman’s Theorem only locally, because the \mathfrak{t} -fibers are not necessarily connected. Therefore we give a direct argument: we show that \mathfrak{t} pushes forward the inverse of Ω to a bivector π on M , which is smooth and Poisson because \mathfrak{t} is a submersion — see, e.g., Theorem 7.39.

We claim that, for any $g \in \mathfrak{t}^{-1}(x)$, the bivector π_x^g induced from the symplectic form Ω_g via the surjective linear map $d_g\mathfrak{t} : T_g\Sigma \rightarrow T_xM$ does not depend on g . The bivector π_x^g is uniquely determined by a subspace $W \subset T_xM$ together with a nondegenerate bilinear form ω_W on W . Using the diagram

$$\begin{array}{ccc}
 T_g\Sigma & \xrightarrow{d_g\mathfrak{t}} & T_xM \\
 (\Omega_g^{-1})^\sharp \updownarrow \Omega_g^\flat & & \uparrow (\pi_x^g)^\sharp \\
 T_g^*\Sigma & \xleftarrow{(d_g\mathfrak{t})^*} & T_x^*M
 \end{array}$$

and the previous proposition, we find that

$$W = d_g\mathfrak{t}((\text{Ker } d_g\mathfrak{t})^\perp) = d_g\mathfrak{t}(\text{Ker } d_g\mathfrak{s}).$$

This is the tangent space to the orbit of Σ through x , and so it is independent of $g \in \mathfrak{t}^{-1}(x)$. The diagram also shows that ω_W is uniquely determined by

$$(d\mathfrak{t}|_{\text{Ker } d_g\mathfrak{s}})^*\omega_W = \Omega|_{\text{Ker } d_g\mathfrak{s}}.$$

Also this form is independent of $g \in \mathfrak{t}^{-1}(x)$ since any two such points are related by a right translation and $\Omega|_{\text{Ker } d_g\mathfrak{s}}$ is invariant under right translations — see Lemma 14.3.

We are left to check that σ_Ω is a Lie algebroid isomorphism. We will denote the Lie algebroid of Σ by $(A, [\cdot, \cdot]_A, \rho)$.

Since $T_xM \subset T_{\mathbf{u}(x)}\Sigma$ is a Lagrangian subspace, it is the kernel of

$$T_{\mathbf{u}(x)}\Sigma \rightarrow T_x^*M, \quad v \mapsto -(i_v\Omega)|_{T_xM}.$$

Since $T_{\mathbf{u}(x)}\Sigma = T_xM \oplus A_x$, it follows that σ_Ω is a linear isomorphism.

Since $\iota : (\Sigma, \Omega) \rightarrow (\Sigma, -\Omega)$ is a symplectomorphism which switches \mathfrak{s} and \mathfrak{t} , it follows that $\mathfrak{s} : (\Sigma, -\Omega) \rightarrow (M, \pi)$ is a symplectic realization. We claim that the corresponding infinitesimal action is given by

$$\mathfrak{a} : \Omega^1(M) \rightarrow \mathfrak{X}(\Sigma), \quad \mathfrak{a}(\sigma_\Omega(\alpha)) = \overleftarrow{\alpha} \quad (\alpha \in \Gamma(A)).$$

Since the infinitesimal action preserves Lie brackets and since the bracket on A comes from the left-invariant vector fields on Σ , this claim implies that σ_Ω preserves Lie brackets, and therefore also anchors, and thus, it is a Lie algebroid isomorphism.

The claim is equivalent to

$$(14.2) \quad i_{\overleftarrow{\alpha}}\Omega = -\mathfrak{s}^*(\sigma_\Omega(\alpha)).$$

This follows by observing that for any left-invariant vector field $\overleftarrow{\alpha}$ we have

$$\Omega_g(\overleftarrow{\alpha}, v) = \Omega_{\mathbf{s}(g)}(\alpha, d_g \mathbf{s}(v)), \quad \forall v \in T_g \Sigma.$$

To see that this last identity holds, we set $x = \mathbf{s}(g)$ and then write

$$\overleftarrow{\alpha}_g = d_{(g, 1_x)} \mathbf{m}(0_g, \alpha_{\mathbf{s}(g)}), \quad v = d_{(g, 1_x)} \mathbf{m}(v, d_g \mathbf{s}(v))$$

and use multiplicativity of Ω .

For (i), using inversion, it suffices to show that $\mathbf{s} : (\Sigma, -\Omega) \rightarrow (M, \pi)$ is a complete symplectic realization. We start with $H \in C^\infty(M)$ such that $X_H \in \mathfrak{X}(M)$ is complete. By (14.2)

$$X_{H \circ \mathbf{s}} = \overleftarrow{\alpha}, \quad \text{where } \alpha = \sigma_\Omega^{-1}(dH) \in \Gamma(A).$$

Since $\rho(\alpha) = X_H \in \mathfrak{X}(M)$ is complete, it follows by the general properties of left-invariant vector fields — see Proposition 13.37 — that $\overleftarrow{\alpha} \in \mathfrak{X}(\Sigma)$ is a complete vector field; i.e., $X_{H \circ \mathbf{s}}$ is complete.

The connected components of the orbits of Σ and the symplectic leaves of π give two partitions of M by immersed submanifolds. By the definition of the orbits, their tangent spaces are given by $\text{Im } \rho$ — see Section 13.1. Since $\text{Im } \rho = \text{Im } \pi^\# \circ \sigma_\Omega$, Proposition 1.8 implies that the symplectic leaves coincide with the connected components of the orbits of Σ . □

Exercise 14.11. Find the Poisson structure induced on the base of the symplectic groupoids given in Examples 14.5, 14.6, and 14.7.

14.2. Examples

In this section, we look at various examples of Poisson manifolds and try to realize them as the base of a symplectic groupoid. The general integrability theory behind this procedure will be discussed in the next sections.

It is useful to observe that, given a Poisson manifold (M, π) , the search for a symplectic groupoid $(\Sigma, \Omega) \rightrightarrows M$ inducing the given π on the base is part of the search for symplectic realizations of (M, π) : Theorem 14.10 shows that the target map of Σ will give such a symplectic realization — even a complete one! Although finding a symplectic realization $\mu : (S, \omega) \rightarrow (M, \pi)$ is typically quite far from finding an actual symplectic groupoid, even when $\dim S = 2 \dim M$, the examples will show that often “natural” symplectic realizations of (M, π) end up being symplectic groupoids. One reason behind this phenomenon is the following result. The existence part in the theorem will be proved later.

Theorem 14.12 (Coste, Dazord, and Weinstein [37]). *Let $\mu : (S, \omega) \rightarrow (M, \pi)$ be a symplectic realization with connected fibers and a Lagrangian section $u : M \rightarrow S$. Then there exists at most one symplectic groupoid*

structure on $(S, \omega) \rightrightarrows M$ with target map $\mathbf{t} = \mu$ and unit section $\mathbf{u} = u$. This exists precisely when the following hold:

- (i) The symplectic realization is complete.
- (ii) Each leaf of the symplectic orthogonal foliation $(\text{Ker } d\mu)^{\perp\omega}$ intersects the Lagrangian section in precisely one point.

Proof. Assume that there is a symplectic groupoid structure on $(S, \omega) \rightrightarrows M$ with target $\mathbf{t} = \mu$ and unit $\mathbf{u} = u$. Then (i) must hold by Theorem 14.10. Since the \mathbf{t} -fibers of S are connected, so are the \mathbf{s} -fibers, and since they are symplectic orthogonal to each other, it follows that the \mathbf{s} -fibers are the leaves of $(\text{Ker } d\mu)^{\perp\omega}$. Hence (ii) must hold.

Next we show that such a groupoid structure is unique. We already know that $\mathbf{s} : S \rightarrow M$ is determined uniquely. Next note that $\omega, u,$ and $\mu = \mathbf{t}$ determine the Lie algebroid as a vector space is $A := u^*(\text{Ker } d\mu)$ and the corresponding map $\sigma_\omega : A \xrightarrow{\sim} T^*M$. Therefore, the left-invariant vector fields are determined by (14.2):

$$i_{\overleftarrow{\alpha}}\omega = -\mathbf{s}^*(\sigma_\omega(\alpha)), \quad \forall \alpha \in \Gamma(A).$$

Using left-invariance of $\overleftarrow{\alpha}$, the multiplication satisfies

$$\mathbf{m}(g, \phi_{\overleftarrow{\alpha}}^{\mathbf{t}}(u(\mathbf{s}(g)))) = \phi_{\overleftarrow{\alpha}}^{\mathbf{t}}(g).$$

This determines the multiplication around the unit section. Since the \mathbf{s} -fibers are connected, it determines the multiplication everywhere — see Proposition 13.7.

The proof of existence is deferred to Section 14.7. □

The proof above gives a recipe to construct the groupoid structure. For the source map we have to find the leaves of the symplectic orthogonal foliation, i.e., the orbit foliation. Each orbit will intersect the section u at a single point and that defines the source map. The proof also shows how to find the multiplication, but this method is hard to apply in practice — however, see Problem 14.6 for an example where this works. We now illustrate the use of these techniques.

Example 14.13. Consider the linear Poisson structure on \mathbb{R}^2 given by

$$\{x, y\} = x$$

and the symplectic realization we found in Section 6.3,

$$\mu : \mathbb{R}^4 \rightarrow \mathbb{R}^2, \quad (x, y, u, v) \mapsto (x, y),$$

with symplectic form — see (6.10):

$$\omega = e^v (du \wedge dx + xdu \wedge dv) + dv \wedge dy.$$

This is a symplectic realization with connected fibers and it admits the global Lagrangian section

$$u : \mathbb{R}^2 \rightarrow \mathbb{R}^4, \quad u(x, y) = (x, y, 0, 0).$$

We proceed to calculate the orbit foliation, which is spanned by

$$\mathfrak{a}(dx) = (\omega^{-1})^\sharp(dx) = x \frac{\partial}{\partial y} + e^{-v} \frac{\partial}{\partial u}, \quad \mathfrak{a}(dy) = (\omega^{-1})^\sharp(dy) = -x \frac{\partial}{\partial x} + \frac{\partial}{\partial v}.$$

These vector fields have flows given by

$$\phi^t(x, y, u, v) = (x, y + xt, u + e^{-v}t, v), \quad \psi^t(x, y, u, v) = (e^{-t}x, y, u, t + v).$$

Let $f : \mathbb{R}^4 \rightarrow \mathbb{R}$ be a smooth function constant on the orbits of \mathfrak{a} . Using $t = -v$ for the second flow and then $t = -u$ for the first, we obtain that

$$f(x, y, u, v) = f(xe^v, y, u, 0) = f(xe^v, y - xue^v, 0, 0).$$

So the orbit foliation coincides with the fibers of the submersion

$$\mathbb{R}^4 \rightarrow \mathbb{R}^2, \quad (x, y, u, v) \mapsto (xe^v, y - xue^v).$$

Since μ is the simpler map, we choose it to be the source map, and we choose the last map to be the target map. Since the source map is anti-Poisson, we are forced to change the sign of the symplectic form on \mathbb{R}^4 :

$$\Omega := -\omega = e^v(dx \wedge du + xdv \wedge du) + dy \wedge dv.$$

Next, to find the multiplication, consider two composable ‘‘arrows’’

$$\mathbf{s}(x', y', u', v') = \mathbf{t}(x, y, u, v) \iff x' = xe^v, y' = y - xue^v.$$

The expression for $\mathbf{t}(x', y', u', v')$ then yields

$$x'e^{v'} = xe^{v+v'}, \quad y' - x'u'e^{v'} = y - x(ue^{-v'} + u')e^{v+v'}.$$

It follows that the product arrow $(x, y, U, V) = (x', y', u', v') \cdot (x, y, u, v)$ can be depicted schematically as

$$\begin{array}{ccccc} & & (x, y, U, V) & & \\ & \swarrow \text{---} & & \searrow \text{---} & \\ (x'e^{v'}, y' - x'u'e^{v'}) & \xleftarrow{(x', y', u', v')} & (x', y') & \xleftarrow{(x, y, u, \bar{v})} & (x, y) \\ \parallel & & \parallel & & \\ (xe^{v+v'}, y - x(ue^{-v'} + u')e^{v+v'}) & & (xe^v, y - xue^v) & & \end{array}$$

which suggests taking

$$U = ue^{-v'} + u', \quad V = v + v',$$

so there is a natural candidate for a multiplication on \mathbb{R}^4 . Altogether, we obtain

$$\begin{array}{ccc} \mathbb{R}^4 & & \\ \downarrow \text{t} & \parallel & \\ \mathbb{R}^2 & \downarrow \text{s} & \end{array} \quad \text{with} \quad \begin{cases} \Omega = e^v (dx \wedge du + xdv \wedge du) + dy \wedge dv, \\ \mathbf{s}(x, y, u, v) = (x, y), \\ \mathbf{t}(x, y, u, v) = (xe^v, y - xue^v), \\ (x', y', u', v') \cdot (x, y, u, v) = (x, y, ue^{-v'} + u', v + v'). \end{cases}$$

One can check directly that this is, indeed, a symplectic groupoid for which the induced Poisson structure on the base is precisely $\{x, y\} = x$. Note also that, as a groupoid, this is an action groupoid: $G = \mathbb{R}^2$ is the group with multiplication

$$(u', v') \cdot (u, v) = (ue^{-v'} + u', v + v'),$$

acting on \mathbb{R}^2 from the left by

$$(u, v) \cdot (x, y) = (xe^v, y - xue^v).$$

It is easy to check that G integrates the 2-dimensional, nonabelian Lie algebra \mathfrak{g} and that this action is the coadjoint action of G on \mathfrak{g}^* , which matches what we have seen in Example 14.7. 

Example 14.14. Consider the symplectic realization of the LV-type Poisson structure on \mathbb{R}^2

$$\{x, y\} = xy,$$

discussed in Example 6.12. As in the previous example, we look for a symplectic groupoid with source

$$\mu : \mathbb{R}^4 \rightarrow \mathbb{R}^2, \quad (x, y, u, v) \mapsto (x, y),$$

and so we change the sign in the symplectic form:

$$\Omega = -d(xu) \wedge d(yv) + dx \wedge du + dy \wedge dv.$$

Then $\mathbf{s} := \mu$ has connected fibers and admits the Lagrangian section

$$\mathbf{u} : \mathbb{R}^2 \rightarrow \mathbb{R}^4, \quad (x, y) \mapsto (x, y, 0, 0).$$

To find the target map, we can proceed the same way as in the previous example. We look for functions $f : \mathbb{R}^4 \rightarrow \mathbb{R}$ constant on the orbits of the action and, hence, constant on the integral curves of the vector fields

$$(\Omega^{-1})^\sharp(dx) = -xy \frac{\partial}{\partial y} - \frac{\partial}{\partial u} + xv \frac{\partial}{\partial v}, \quad (\Omega^{-1})^\sharp(dy) = xy \frac{\partial}{\partial x} - yu \frac{\partial}{\partial u} - \frac{\partial}{\partial v}.$$

Their flows are given by

$$\phi^t(x, y, u, v) = (x, ye^{-tx}, u - t, ve^{tx}), \quad \psi^t(x, y, u, v) = (xe^{ty}, y, ue^{-ty}, v - t),$$

so if f is constant on the orbits, using $t = u$ for ϕ^t and then $t = ve^{xu}$ for ψ^t we find that

$$f(x, y, u, v) = f(x, ye^{-ux}, 0, ve^{xu}) = f(xe^{yv}, ye^{-xu}, 0, 0).$$

This gives the expression for the target map

$$\mathbf{t}(x, y, u, v) = (xe^{yv}, ye^{-xu}),$$

which appeared in Exercise 6.31.

Next, to find the multiplication, consider two composable “arrows”

$$\mathbf{s}(x', y', u', v') = \mathbf{t}(x, y, u, v) \iff x' = xe^{yv}, \quad y' = ye^{-xu},$$

and replacing these in $\mathbf{t}(x', y', u', v')$, one finds

$$x'e^{y'v'} = xe^{y(v+e^{-xu}v')}, \quad y'e^{-x'u'} = ye^{-x(u+e^{yv}u')}.$$

Given this information, the product (x, y, U, V) of the two arrows can be depicted schematically as

$$\begin{array}{ccccc} & & (x, y, U, V) & & \\ & \swarrow & \text{---} & \searrow & \\ (x'e^{y'v'}, y'e^{-x'u'}) & \xleftarrow{(x', y', u', v')} & (x', y') & \xleftarrow{(x, y, u, v)} & (x, y) \\ \parallel & & \parallel & & \\ (xe^{y(v+e^{-xu}v')}, ye^{-x(u+e^{yv}u')}) & & (xe^{yv}, ye^{-xu}) & & \end{array}$$

which suggests taking

$$U = u + e^{yv}u', \quad V = v + e^{-xu}v'.$$

We find the symplectic groupoid

$$\begin{array}{c} \mathbb{R}^4 \\ \mathbf{t} \downarrow \downarrow \mathbf{s} \\ \mathbb{R}^2 \end{array} \quad \text{with} \quad \begin{cases} \Omega = -d(xu) \wedge d(yv) + dx \wedge du + dy \wedge dv, \\ \mathbf{s}(x, y, u, v) = (x, y), \\ \mathbf{t}(x, y, u, v) = (xe^{yv}, ye^{-xu}), \\ (x', y', u', v') \cdot (x, y, u, v) = (x, y, u + e^{yv}u', v + e^{-xu}v'), \end{cases}$$

inducing the Poisson structure $\{x, y\} = xy$ on the base. Inversion in this groupoid is the antisymplectic involution of Exercise 6.13(c). This groupoid is no longer an action groupoid.

Exercise 14.15. Consider the Poisson structure on \mathbb{R}^2 given by $\{x, y\} = axy$, with $a \in \mathbb{R}$ fixed. Show that one has a symplectic groupoid $\mathbb{R}^4 \rightrightarrows \mathbb{R}^2$ integrating it, with symplectic form

$$\Omega = dx \wedge du + dy \wedge dv - ad(xu) \wedge d(yv),$$

while the source, target, and multiplication maps are

$$\begin{aligned} \mathbf{s}(x, y, u, v) &= (x, y), & \mathbf{t}(x, y, u, v) &= (xe^{ayv}, ye^{-axu}), \\ (x', y', u', v') \cdot (x, y, u, v) &= (x, y, u + e^{ayv}u', v + e^{-axu}v'). \end{aligned}$$

This should be compared with the symplectic realization (6.5).



Example 14.16. Let us consider now the Poisson structure on \mathbb{R}^2 given by

$$\{x, y\} = x^2 + y^2,$$

discussed in Example 6.16. One can proceed along the same lines as the previous two examples or, alternatively, exploit the relationship with the Poisson structure in the previous example, as in Example 6.16. In any case, using complex coordinates $z = x + iy$ and $\eta = v - iu$, the outcome is the symplectic groupoid

$$\begin{array}{c} \mathbb{C}^2 \\ \mathbf{t} \downarrow \downarrow \mathbf{s} \\ \mathbb{C} \end{array} \quad \text{with} \quad \begin{cases} \mathbf{s}(z, \eta) = z, \\ \mathbf{t}(z, \eta) = z \cdot e^{\bar{z}\eta}, \\ (z', \eta') \cdot (z, \eta) = (z, \eta + e^{z\bar{\eta}}\eta') \end{cases}$$

with symplectic form

$$\begin{aligned} \Omega = \frac{i}{2}(\eta \bar{\eta} dz \wedge d\bar{z} - z \bar{z} d\eta \wedge d\bar{\eta} + \bar{z} \eta dz \wedge d\eta + \\ - z \eta d\bar{z} \wedge d\bar{\eta} - dz \wedge d\bar{\eta} + d\bar{z} \wedge d\eta). \end{aligned}$$

This example was first constructed in [3] by using a different method. 

We now move to examples of symplectic groupoids integrating general classes of Poisson manifolds.

Example 14.17 (Symplectic manifolds). Given a symplectic manifold (M, ω) , we saw in Example 14.5 that the pair groupoid $M \times M \rightrightarrows M$ is a symplectic groupoid for the symplectic form

$$(14.3) \quad \Omega := \mathbf{t}^*\omega - \mathbf{s}^*\omega.$$

The target map $\mathbf{t} = \text{pr}_1 : (M \times M, \Omega) \rightarrow (M, \omega)$ is clearly Poisson. Moreover, the Lie algebroid of $M \times M$ is the tangent bundle TM and the isomorphism of Theorem 14.10 is just the isomorphism $\sigma_\Omega = \omega^\flat : TM \xrightarrow{\sim} T^*M$.

For a concrete example consider $M = \mathbb{R}^2$ with the canonical Poisson structure $\{p, q\} = 1$. The symplectic groupoid is

$$\begin{array}{c} \mathbb{R}^4 \\ \mathbf{t} \downarrow \downarrow \mathbf{s} \\ \mathbb{R}^2 \end{array} \quad \text{with} \quad \begin{cases} \Omega = dq_1 \wedge dp_1 - dq_2 \wedge dp_2, \\ \mathbf{s}(q_1, p_1, q_2, p_2) = (q_2, p_2), \\ \mathbf{t}(q_1, p_1, q_2, p_2) = (q_1, p_1), \\ (q_1, p_1, q_2, p_2) \cdot (q_2, p_2, q_3, p_3) = (q_1, p_1, q_3, p_3). \end{cases}$$

Actually for any Lie groupoid integrating TM the 2-form (14.3) is symplectic and multiplicative. In particular, the homotopy groupoid $\Pi(M) \rightrightarrows M$ — see Example 13.12 — is a symplectic groupoid.

Exercise 14.18. Given a Lie groupoid $\Sigma \rightrightarrows M$ and a 2-form $\omega \in \Omega^2(M)$, show that the multiplicative form

$$\Omega = \mathbf{t}^*\omega - \mathbf{s}^*\omega$$

is symplectic if and only if Σ integrates TM and ω is symplectic. 

Example 14.19 (Zero Poisson structure). We saw in Example 14.6 that the cotangent bundle of any manifold M , endowed with the canonical symplectic form, can be viewed as a symplectic groupoid

$$(T^*M, \omega_{\text{can}}) \rightrightarrows M.$$

We now have $\text{pr} = \mathbf{s} = \mathbf{t}$, so the induced Poisson structure on the base is the zero Poisson structure. In this case, the Lie algebroid is T^*M and the isomorphism given by Theorem 14.10 is the identity map. For example, if $M = \mathbb{R}^2$, we find the symplectic groupoid

$$\begin{array}{c} \mathbb{R}^4 \\ \mathbf{t} \downarrow \quad \downarrow \quad \mathbf{s} \\ \mathbb{R}^2 \end{array} \quad \text{with} \quad \begin{cases} \Omega = dx \wedge du + dy \wedge dv, \\ \mathbf{s}(x, y, u, v) = \mathbf{t}(x, y, u, v) = (x, y), \\ (x, y, u', v') \cdot (x, y, u, v) = (x, y, u + u', v + v'). \end{cases}$$

We saw in Example 14.6 that any integrable lattice $\Lambda \subset T^*M$ gives a symplectic groupoid inducing the zero Poisson structure

$$(\mathcal{T}_\Lambda, \omega_\Lambda) \rightrightarrows M.$$

The following exercise discusses even more general such symplectic groupoids.

Exercise 14.20. Let $(\Sigma, \Omega) \rightrightarrows M$ be a symplectic groupoid. Show that the following are equivalent:

- (i) The induced Poisson structure on the base vanishes.
- (ii) The anchor of the Lie algebroid of \mathcal{G} vanishes.
- (iii) Σ is a bundle of Lie groups.

In this case, if the \mathbf{t} -fibers are connected, then (Σ, Ω) must be a quotient of $(T^*M, \omega_{\text{can}})$ modulo a family of discrete subgroups $\Lambda \subset T^*M$ which is a Lagrangian submanifold — but not necessarily a lattice. 

Example 14.21 (Constant Poisson structures). Consider a constant Poisson structure $\pi_V \in \wedge^2 V$ on a vector space V . As we saw in Example 6.10, the Poisson manifold (V, π_V) can be written as the product of a symplectic manifold (W, ω_W) and a Poisson manifold endowed with the zero Poisson structure $(C, 0)$: $W = \text{Im } \pi_V^\sharp$ and C is any complement to W in V . Their symplectic groupoid can be constructed by noting that, in general, the product of two symplectic groupoids $(\Sigma_i, \Omega_i) \rightrightarrows M_i$ gives a symplectic groupoid

$$(\Sigma_1 \times \Sigma_2, \text{pr}_1^* \Omega_1 + \text{pr}_2^* \Omega_2) \rightrightarrows M_1 \times M_2.$$

Moreover, the induced Poisson structure on $M_1 \times M_2$ is the product of the two Poisson structures induced by Σ_i on M_i . 

Example 14.22 (Linear Poisson structures). As we saw in Example 14.7, for a Lie group G we have the symplectic groupoid

$$(T^*G \simeq G \times \mathfrak{g}^*, \Omega) \rightrightarrows \mathfrak{g}^*,$$

where $\Omega = -\omega_{\text{can}}$ and the source map is the projection. Since the projection is an antisymplectic realization of the linear Poisson structure — see Section 6.3 — this symplectic groupoid is an integration of $(\mathfrak{g}^*, \pi_{\mathfrak{g}})$.

We have already observe that Example 14.13 is a particular case of this construction. For another concrete example, consider the linear Poisson structure on \mathbb{R}^3 discussed in Section 6.3:

$$\{x, y\} = z, \quad \{y, z\} = x, \quad \{z, x\} = y.$$

This is associated with the Lie algebra $\mathfrak{so}(3, \mathbb{R})$ which admits as integrations the Lie groups $\text{SO}(3, \mathbb{R})$ and $\text{SU}(2)$. Let us consider $\text{SU}(2)$ and identify it with \mathbb{S}^3 viewed as the quaternions of norm 1:

$$\zeta = (u, v, s, t) \mapsto u + v\vec{i} + s\vec{j} + t\vec{k}.$$

If we also identify \mathbb{R}^3 with purely imaginary quaternions via

$$\vec{r} = (x, y, z) \mapsto x\vec{i} + y\vec{j} + z\vec{k},$$

one finds the explicit symplectic groupoid

$$\begin{array}{ccc} \mathbb{S}^3 \times \mathbb{R}^3 & & ((u, v, s, t), (x, y, z)) = (\zeta, \vec{r}) \\ \begin{array}{c} \downarrow \text{t} \\ \downarrow \text{s} \\ \mathbb{R}^3 \end{array} & \begin{array}{c} \swarrow \text{t} \\ \searrow \text{s} \end{array} & \begin{array}{c} \zeta \cdot \vec{r} \cdot \zeta^{-1} \\ \vec{r} = (x, y, z) \end{array} \end{array}$$

with the symplectic form $\Omega = d\Theta$, where Θ corresponds to the Liouville 1-form and is given explicitly by (see also Exercise 6.19)

$$\begin{aligned} \Theta = & -(xv + ys + zt)du + (xu - yt + zs)dv \\ & + (xt + yu - zv)ds + (-xs + yv + zu)dt. \end{aligned} \quad \text{fish icon}$$

Example 14.23 (LV-type Poisson structures). For the general LV-type Poisson structure,

$$\{x^i, x^j\} = a^{ij}x^i x^j,$$

we found in Example 6.12 the symplectic realization

$$\mu : \mathbb{R}^{2n} \rightarrow \mathbb{R}^n, \quad \mu(x^i, u^i) = (x^i).$$

The fibers of μ are 1-connected, and μ admits the Lagrangian section

$$\mathbf{u} : \mathbb{R}^n \rightarrow \mathbb{R}^{2n}, \quad (x^i) \mapsto (x^i, 0).$$

Generalizing Example 14.14, one obtains a symplectic groupoid $\mathbb{R}^{2n} \rightrightarrows \mathbb{R}^n$ integrating this Poisson structure, with source map $\mathbf{s} = \mu$, unit section \mathbf{u} , and symplectic form the opposite of (6.6)

$$\Omega = \sum_{i=1}^n dx^i \wedge du^i - \sum_{i,j=1}^n \frac{1}{2} a^{ij} d(x^i u^i) \wedge d(x^j u^j).$$

Applying the same reasoning as in that example, one obtains as target map

$$\mathbf{t} : \mathbb{R}^{2n} \rightarrow \mathbb{R}^n, \quad (x^i, u^i) \mapsto (x^i e^{\sum_{j=1}^n a^{ij} x^j u^j})$$

and as multiplication

$$(\bar{x}^i, \bar{u}^i) \cdot (x^i, u^i) = (x^i, u^i + \bar{u}^i e^{\sum_{j=1}^n a^{ij} x^j u^j}).$$

Interesting enough, precisely this symplectic groupoid was also discovered in [107] in the context of cluster manifolds. 

Example 14.24 (Duals of Lie algebroids). Recall that for any Lie algebroid $(A, [\cdot, \cdot]_A, \rho)$, the dual vector bundle A^* is endowed with the fiberwise linear Poisson structure π_A — see Section 13.5. The cotangent Lie groupoid

$$(T^*\mathcal{G}, \Omega) \rightrightarrows A^*$$

then becomes a symplectic groupoid where $\Omega = -\omega_{\text{can}} = d\theta_L$. This generalizes the previous example, and we leave the proof as an exercise.

Exercise 14.25. Show that the Liouville 1-form $\theta_L \in \Omega^1(T^*\mathcal{G})$ is multiplicative. Moreover, verify that the induced Poisson structure on the base is the fiberwise linear Poisson structure π_A .

In particular, Theorem 14.10 implies Proposition 13.76. 

Example 14.26 (Quotient Poisson structures). Consider a quotient Poisson manifold $(M = S/G, \pi)$ of a free and proper Hamiltonian G -space (S, ω, μ) . Since the moment map $\mu : S \rightarrow \mathfrak{g}^*$ is a submersion, we can form the submersion groupoid (see Example 13.11)

$$S \times_{\mu} S \rightrightarrows S.$$

The 2-form

$$\text{pr}_1^* \omega - \text{pr}_2^* \omega \in \Omega^2(S \times_{\mu} S)$$

is multiplicative and closed, and its kernel is given by the orbits of the diagonal action of G on $S \times_{\mu} S$. This action leaves invariant the form and is by groupoid automorphisms. It follows that the quotient

$$\Sigma := (S \times_{\mu} S)/G \rightrightarrows S/G = M$$

is a symplectic groupoid where Ω is the unique form satisfying

$$(14.4) \quad q^*\Omega = \text{pr}_1^*\omega - \text{pr}_2^*\omega,$$

where $q : S \times_\mu S \rightarrow (S \times_\mu S)/G$ is the quotient map.

For the Poisson structure on $M = S/G$, we have a commutative diagram

$$\begin{array}{ccc} (S \times_\mu S, \text{pr}_1^*\omega - \text{pr}_2^*\omega) & \xrightarrow{\text{pr}_1} & (S, \omega) \\ \downarrow & & \downarrow \\ (\Sigma, \Omega) & \xrightarrow{\text{t}} & (M, \pi) \end{array}$$

where the top row and the vertical arrows are forward Dirac maps. Since all maps are submersions, the bottom row must also be a forward Dirac map, i.e., a Poisson map — see Problem 7.6. Hence, π is the Poisson structure induced on M by this symplectic groupoid.

The Lie algebroid of Σ is the subalgebroid of the Atiyah algebroid TS/G given by the quotient bundle

$$A = (\text{Ker } d\mu)/G \rightarrow M.$$

The isomorphism $\sigma_\Omega : A \rightarrow T^*M$, given by Theorem 14.10 can be described as the composition of two bundle maps

$$A = (\text{Ker } d\mu)/G \xrightarrow{\cong} (\text{Im } \mathfrak{a})^\circ/G \xrightarrow{\cong} T^*M .$$

The second map is induced by pullback along the quotient map $S \rightarrow S/G$, and the first map is the one induced on the quotients by

$$\text{Ker}(d\mu) \rightarrow T^*S, \quad v \rightarrow i_v\omega,$$

whose image is the annihilator of the image of $\mathfrak{a} : \mathfrak{g} \times S \rightarrow TS$.

Exercise 14.27. Apply the above construction to obtain a symplectic groupoid integrating the linear model of Section 4.4. 

14.3. Integrability of Poisson structures I

The results in the previous section raise the following question:

Integrability Problem: Given a Poisson manifold (M, π) , is there a symplectic groupoid $(\Sigma, \Omega) \rightrightarrows M$ inducing π ?

Whenever a solution of the integrability problem exists we say that (M, π) is an **integrable Poisson manifold**. A solution (Σ, Ω) is called a **symplectic integration** of (M, π) . One should think of it as a “symplectic desingularization” of (M, π) . The rest of this chapter is dedicated to this fundamental problem.

We already know that if a symplectic integration (Σ, Ω) exists, then its Lie algebroid must be isomorphic to $(T^*M, [\cdot, \cdot]_\pi, \pi^\sharp)$. So the integrability problem can be split into two steps:

- 1) Is there a Lie groupoid $\Sigma \rightrightarrows M$ with Lie algebroid isomorphic to T^*M ?
- 2) If $\Sigma \rightrightarrows M$ has Lie algebroid isomorphic to T^*M , does Σ carry a multiplicative symplectic form Ω ?

We will consider the first step in later sections. For now, we will assume that the Poisson manifold (M, π) has integrable Lie algebroid T^*M and study if an integration $\Sigma \rightrightarrows M$ carries a symplectic form Ω . In general, the answer to this question is no, as shown already by examples with the zero Poisson structure.

Example 14.28. Consider the 3-sphere \mathbb{S}^3 with the zero Poisson structure. We saw that it has the symplectic integration $T^*\mathbb{S}^3 \simeq \mathbb{S}^3 \times \mathbb{R}^3 \rightarrow \mathbb{S}^3$, which is a bundle of Lie groups with addition on the fibers and multiplicative symplectic form $\Omega = \omega_{\text{can}}$. The bundle of Lie groups $\mathcal{G} = \mathbb{S}^3 \times \mathbb{T}^3 \rightarrow \mathbb{S}^3$ with the usual abelian Lie group structure on \mathbb{T}^3 is also an integration of the cotangent Lie algebroid $T^*\mathbb{S}^3$. However, \mathcal{G} is not a symplectic groupoid since $\mathbb{S}^3 \times \mathbb{T}^3$ does not carry any symplectic form. This follows because every class $c \in H^2(\mathbb{S}^3 \times \mathbb{T}^3)$ squares to zero: $c^2 = 0$. 

By Lie's First Theorem, given any integration of the cotangent Lie algebroid of a Poisson manifold we can find one that has 1-connected \mathfrak{t} -fibers. It turns out that such an integration is always a symplectic integration:

Theorem 14.29 (Mackenzie and Xu [115]). *Let (M, π) be a Poisson manifold, let $\Sigma \rightrightarrows M$ be a Lie groupoid with 1-connected \mathfrak{t} -fibers, and let $\sigma : A \rightarrow T^*M$ be a Lie algebroid isomorphism. Then there exists a unique multiplicative symplectic form $\Omega \in \Omega^2(\Sigma)$ with the property that the Lie algebroid isomorphism σ_Ω given by (14.1) coincides with σ .*

There are several approaches to proving this theorem, each of them exhibiting a different facet of Poisson geometry. We will present two proofs, which will occupy the rest of this section.

First proof of Theorem 14.29. The following result for general 2-forms on groupoids will play a crucial role.

Proposition 14.30. *Let $\mathcal{G} \rightrightarrows M$ be a Lie groupoid with connected \mathfrak{t} -fibers. For a 2-form $\Omega \in \Omega^2(\mathcal{G})$, define the bundle map*

$$\sigma_\Omega : A \rightarrow T^*M, \quad \sigma_\Omega(\alpha) = -\mathbf{u}^*(i_\alpha \Omega).$$

Then Ω is multiplicative and closed if and only if, for all $\alpha \in \Gamma(A)$,

$$(C0) \quad i_{\overleftarrow{\alpha}}\Omega = -\mathbf{s}^*(\sigma_{\Omega}(\alpha)),$$

$$(C1) \quad i_{\overleftarrow{\alpha}}d\Omega = 0,$$

$$(C2) \quad \mathbf{u}^*\Omega = 0.$$

Moreover, in this case, Ω is symplectic if and only if σ_{Ω} is an isomorphism.

Proof. Assume that $\Omega \in \Omega^2(\mathcal{G})$ is a closed, multiplicative form. The identity (C2) was verified in the proof of Proposition 14.9 using only multiplicativity of Ω . The identity (C0) was also shown to hold in the proof of Theorem 14.10 — see (14.2) — using again only multiplicativity of Ω .

We now prove the converse. Assuming that the equations in the statement hold, we show that Ω is closed and multiplicative.

- Ω is closed: since $i_{\overleftarrow{\alpha}}d\Omega = 0$ and $d\Omega$ is closed, it follows that $d\Omega$ is \mathbf{s} -basic, i.e., that $d\Omega = \mathbf{s}^*\mu$ for some $\mu \in \Omega^3(M)$. But $\mathbf{u}^*\Omega = 0$ implies

$$\mu = \mathbf{u}^*\mathbf{s}^*\mu = \mathbf{u}^*(d\Omega) = d(\mathbf{u}^*\Omega) = 0,$$

showing that $d\Omega = \mathbf{s}^*\mu = 0$.

- Ω is multiplicative: we need to check that

$$\delta\Omega := \text{pr}_1^*\Omega - \mathbf{m}^*\Omega + \text{pr}_2^*\Omega \in \Omega^2(\mathcal{G}^{(2)})$$

vanishes identically. We claim that $\delta\Omega$ is basic relative to $\text{pr}_1 : \mathcal{G}^{(2)} \rightarrow \mathcal{G}$. Observe that the tangent spaces of the fibers are spanned by the vector fields

$$\overleftarrow{\alpha} \in \mathfrak{X}(\mathcal{G}^{(2)}), \quad \overleftarrow{\alpha}_{(g,h)} := dL_{(g,h)}(\alpha_x) \quad (\alpha \in \Gamma(A))$$

where $x = \mathbf{s}(h)$ and

$$L_{(g,h)} : \mathbf{t}^{-1}(x) \rightarrow \mathcal{G}^{(2)}, \quad a \mapsto (g, ha).$$

We already know that $d(\delta\Omega) = 0$, so to check that $\delta\Omega$ is pr_1 -basic we only need to check that $i_{\overleftarrow{\alpha}}\delta\Omega = 0$, for all $\alpha \in \Gamma(A)$. But this follows from

$$\begin{aligned} i_{\overleftarrow{\alpha}}\delta\Omega &= i_{\overleftarrow{\alpha}}\text{pr}_1^*\Omega - i_{\overleftarrow{\alpha}}\mathbf{m}^*\Omega + i_{\overleftarrow{\alpha}}\text{pr}_2^*\Omega \\ &= -\mathbf{m}^*i_{\overleftarrow{\alpha}}\Omega + \text{pr}_2^*i_{\overleftarrow{\alpha}}\Omega = (\mathbf{m}^* - \text{pr}_2^*)\mathbf{s}^*\sigma_{\Omega}(\alpha) = 0, \end{aligned}$$

since $\mathbf{m}^*\mathbf{s}^* = \text{pr}_2^*\mathbf{s}^*$. Therefore, $\delta\Omega = \text{pr}_1^*\tau$ for some $\tau \in \Omega^2(\mathcal{G})$. Now, pulling back by the map $(\text{Id}, \mathbf{u} \circ \mathbf{s}) : \mathcal{G} \rightarrow \mathcal{G}^{(2)}$, we find that

$$0 = \mathbf{s}^*\mathbf{u}^*\Omega = (\text{Id}, \mathbf{u} \circ \mathbf{s})^*\delta\Omega = (\text{Id}, \mathbf{u} \circ \mathbf{s})^*\text{pr}_1^*\tau = \tau,$$

so that $\delta\Omega = \text{pr}_1^*\tau = 0$.

For the last part, assume that Ω is multiplicative and closed. We have seen the direct implication in Theorem 14.10. To prove the converse, assume that σ_{Ω} is an isomorphism. Surjectivity of σ_{Ω} and (C0) imply that $\text{Ker } \Omega \subset \text{Ker } d\mathbf{s}$. Injectivity of σ_{Ω} and (C0) imply that $\text{Ker } \Omega \cap \text{Ker } d\mathbf{t} = 0$. Using

only multiplicativity of Ω , we have seen in the proof of Proposition 14.9 that $\iota^*\Omega = -\Omega$. Since $\mathbf{t} \circ \iota = \mathbf{s}$ it follows that

$$\text{Ker } \Omega = \text{Ker } \Omega \cap \text{Ker } d\mathbf{s} = d\iota(\text{Ker } \Omega \cap \text{Ker } d\mathbf{t}) = 0. \quad \square$$

Uniqueness: In order to prove uniqueness in Theorem 14.29, and also for later use, we show that if Ω is any multiplicative, closed 2-form, possibly degenerate, with $\sigma_\Omega = 0$, then $\Omega = 0$. For this, notice that by (C0) we have

$$i_{\zeta_\alpha} \Omega = -\mathbf{s}^*(\sigma_\Omega(\alpha)) = 0.$$

Since $d\Omega = 0$, it follows that Ω is basic with respect to the submersion $\mathbf{t} : \Sigma \rightarrow M$: there exists a closed 2-form $\tau \in \Omega^2(M)$ such that

$$\Omega = \mathbf{t}^*\tau.$$

Now, the multiplicativity of Ω gives

$$\begin{aligned} 0 = \delta\Omega &= \text{pr}_1^* \Omega - \mathbf{m}^* \Omega + \text{pr}_2^* \Omega \\ (14.5) \quad &= \text{pr}_1^* \mathbf{t}^* \tau - \mathbf{m}^* \mathbf{t}^* \tau + \text{pr}_2^* \mathbf{t}^* \tau = \text{pr}_2^* \mathbf{t}^* \tau = \text{pr}_2^* \Omega \end{aligned}$$

where we used that $\mathbf{t} \circ \mathbf{m} = \mathbf{t} \circ \text{pr}_1$. Hence $\Omega = 0$.

Existence: Given $\sigma : A \rightarrow T^*M$ as in the statement, we are looking for a form $\Omega \in \Omega^2(\Sigma)$ with $\sigma_\Omega = \sigma$ and satisfying (C0), (C1), and (C2) of Proposition 14.30. First we choose Ω satisfying

$$(C0') \quad i_{\zeta_\alpha} \Omega = -\mathbf{s}^*(\sigma(\alpha)), \quad \forall \alpha \in \Gamma(A).$$

This can done by using a complement to $\text{Ker } d\mathbf{t}$ in $T\Sigma$. Note that (C0') implies that $\sigma_\Omega = \sigma$ and therefore also (C0). A simple computation shows that Ω can be modified to also satisfy (C1) and (C2) as follows:

- If $\eta \in \Omega^2(\Sigma)$ satisfies

$$(14.6) \quad i_{\zeta_\alpha} \eta = 0, \quad \mathcal{L}_{\zeta_\alpha} \eta = i_{\zeta_\alpha} d\Omega, \quad \forall \alpha \in \Gamma(A),$$

then $\Omega' := \Omega - \eta$ satisfies (C0') and (C1).

- Next $\Omega'' := \Omega' - \mathbf{t}^* \mathbf{u}^* \Omega$ satisfies all conditions.

This observation reduces the existence problem to a cohomological problem: find a 2-form $\eta \in \Omega^2(\Sigma)$ satisfying (14.6). We will see that this amounts to a ‘‘Poincaré Lemma with parameters’’, along the \mathbf{t} -fibers. To explain this, let $\mathcal{F}_\mathbf{t}$ be the foliation of Σ by \mathbf{t} -fibers and denote by $\nu_\mathbf{t}$ its normal bundle

$$\nu_\mathbf{t} := T\Sigma / T\mathcal{F}_\mathbf{t}.$$

The conormal bundle $\nu_\mathbf{t}^*$ can be canonically identified with the annihilator of the tangent spaces to the target fibers:

$$\nu_\mathbf{t}^* = (\text{Ker } d\mathbf{t})^\circ \subset T^*\Sigma.$$

Notice that the sections of $\bigwedge^2 \nu_{\mathbf{t}}^*$ are the \mathbf{t} -horizontal 2-forms in Σ :

$$\Gamma\left(\bigwedge^2 \nu_{\mathbf{t}}^*\right) = \{\eta \in \Omega^2(\Sigma) : i_{\overleftarrow{\alpha}}\eta = 0, \alpha \in \Gamma(A)\}.$$

Hence, the first equation in (14.6) says that the form η we are looking for is a section of $\bigwedge^2 \nu_{\mathbf{t}}^*$. We now analyse the right-hand side of the second equation.

Lemma 14.31. *For each $\alpha \in \Gamma(A)$, the form $i_{\overleftarrow{\alpha}}d\Omega$ is \mathbf{t} -horizontal, so one obtains a map*

$$\xi_{\Omega} : \Gamma(T\mathcal{F}_{\mathbf{t}}) \rightarrow \Gamma\left(\bigwedge^2 \nu_{\mathbf{t}}^*\right), \quad \overleftarrow{\alpha} \mapsto i_{\overleftarrow{\alpha}}d\Omega.$$

Proof. Using that Ω satisfies (C0') and the general identity

$$(14.7) \quad i_X i_Y d = i_{[X,Y]} + \mathcal{L}_Y i_X - \mathcal{L}_X i_Y + di_X i_Y,$$

we obtain that

$$\begin{aligned} i_{\overleftarrow{\alpha}} i_{\overleftarrow{\beta}} d\Omega &= i_{[\overleftarrow{\alpha}, \overleftarrow{\beta}]} \Omega + \mathcal{L}_{\overleftarrow{\beta}} i_{\overleftarrow{\alpha}} \Omega - \mathcal{L}_{\overleftarrow{\alpha}} i_{\overleftarrow{\beta}} \Omega + di_{\overleftarrow{\alpha}} i_{\overleftarrow{\beta}} \Omega \\ &= -\mathbf{s}^* \sigma([\alpha, \beta]) - \mathcal{L}_{\overleftarrow{\beta}}(\mathbf{s}^* \sigma(\alpha)) + \mathcal{L}_{\overleftarrow{\alpha}}(\mathbf{s}^* \sigma(\beta)) - di_{\overleftarrow{\alpha}} \mathbf{s}^* \sigma(\beta) \\ &= -\mathbf{s}^* \sigma([\alpha, \beta]) - \mathbf{s}^* \mathcal{L}_{\rho(\beta)}(\sigma(\alpha)) + \mathbf{s}^* \mathcal{L}_{\rho(\alpha)}(\sigma(\beta)) - \mathbf{s}^* d(\sigma(\beta)(\rho(\alpha))) \\ &= -\mathbf{s}^* (\sigma([\alpha, \beta]) - \mathcal{L}_{\rho(\alpha)}(\sigma(\beta)) + \mathcal{L}_{\rho(\beta)}(\sigma(\alpha)) + d(\sigma(\beta)(\rho(\alpha)))) \\ &= -\mathbf{s}^* (\sigma([\alpha, \beta]) - \mathcal{L}_{\pi^{\#}\sigma(\alpha)}(\sigma(\beta)) + \mathcal{L}_{\pi^{\#}\sigma(\beta)}(\sigma(\alpha)) + d\pi(\sigma(\alpha), \sigma(\beta))) \\ &= -\mathbf{s}^* (\sigma([\alpha, \beta]) - [\sigma(\alpha), \sigma(\beta)]_{\pi}) = 0, \end{aligned}$$

where we have used that σ is a Lie algebroid homomorphism. This shows that $i_{\overleftarrow{\alpha}}d\Omega$ is \mathbf{t} -horizontal. \square

In other words, we have a foliated 1-form on $\mathcal{F}_{\mathbf{t}}$ with coefficients in $\bigwedge^2 \nu_{\mathbf{t}}^*$:

$$\xi_{\Omega} \in \Omega^1\left(\mathcal{F}_{\mathbf{t}}; \bigwedge^2 \nu_{\mathbf{t}}^*\right).$$

The key remark is that equation (14.6) lives on a version with coefficients of the foliated de Rham complex (see Section C.2)

$$(14.8) \quad \Omega^0\left(\mathcal{F}_{\mathbf{t}}; \bigwedge^2 \nu_{\mathbf{t}}^*\right) \xrightarrow{d_{\mathcal{F}_{\mathbf{t}}}} \Omega^1\left(\mathcal{F}_{\mathbf{t}}; \bigwedge^2 \nu_{\mathbf{t}}^*\right) \xrightarrow{d_{\mathcal{F}_{\mathbf{t}}}} \Omega^2\left(\mathcal{F}_{\mathbf{t}}; \bigwedge^2 \nu_{\mathbf{t}}^*\right) \longrightarrow \dots$$

with the differential given by the usual Koszul-type formula

$$\begin{aligned} d_{\mathcal{F}_{\mathbf{t}}}\eta(\overleftarrow{\alpha}_0, \dots, \overleftarrow{\alpha}_k) &= \sum_{i=0}^k (-1)^i \mathcal{L}_{\overleftarrow{\alpha}_i} \eta(\overleftarrow{\alpha}_0, \dots, \widehat{\overleftarrow{\alpha}_i}, \dots, \overleftarrow{\alpha}_k) \\ &\quad + \sum_{i < j} (-1)^{i+j} \eta([\overleftarrow{\alpha}_i, \overleftarrow{\alpha}_j], \overleftarrow{\alpha}_0, \dots, \widehat{\overleftarrow{\alpha}_i}, \dots, \widehat{\overleftarrow{\alpha}_j}, \dots, \overleftarrow{\alpha}_k). \end{aligned}$$

In particular,

$$d_{\mathcal{F}_t} : \Omega^0\left(\mathcal{F}_t; \bigwedge^2 \nu_t^*\right) \rightarrow \Omega^1\left(\mathcal{F}_t; \bigwedge^2 \nu_t^*\right), \quad d_{\mathcal{F}_t} \eta(\overleftarrow{\alpha}) = \mathcal{L}_{\overleftarrow{\alpha}} \eta.$$

In conclusion, while Ω gives rise to ξ_Ω , equation (14.6) becomes

$$(14.9) \quad d_{\mathcal{F}_t} \eta = \xi_\Omega, \quad \text{with } \eta \in \Omega^0\left(\mathcal{F}_t; \bigwedge^2 \nu_t^*\right).$$

Note first that $\xi_\Omega \in \Omega^1(\mathcal{F}_t; \bigwedge^2 \nu_t^*)$ is $d_{\mathcal{F}_t}$ -closed. This amounts to

$$i_{[\overleftarrow{\alpha}, \overleftarrow{\beta}]} d\Omega = \mathcal{L}_{\overleftarrow{\alpha}} i_{\overleftarrow{\beta}} d\Omega - \mathcal{L}_{\overleftarrow{\beta}} i_{\overleftarrow{\alpha}} d\Omega,$$

which follows immediately from the general identity (14.7).

The proof of the theorem will be completed by showing that

$$\Omega^0\left(\mathcal{F}_t; \bigwedge^2 \nu_t^*\right) \xrightarrow{d_{\mathcal{F}_t}} \Omega^1\left(\mathcal{F}_t; \bigwedge^2 \nu_t^*\right) \xrightarrow{d_{\mathcal{F}_t}} \Omega^2\left(\mathcal{F}_t; \bigwedge^2 \nu_t^*\right)$$

is exact. For this we use 1-connectedness of the \mathbf{t} -fibers of Σ . Note that $\bigwedge^2 \nu_t^*$ is isomorphic to the pullback along $\mathbf{t} : \Sigma \rightarrow M$ of $\bigwedge^2 T^*M$:

$$\bigwedge^2 \nu_t^* = \mathbf{t}^* \bigwedge^2 T^*M.$$

We see that, given any $\theta \in \Omega^1(\mathcal{F}_t; \bigwedge^2 \nu_t^*)$ which is $d_{\mathcal{F}_t}$ -closed, we can restrict to each fiber $\mathbf{t}^{-1}(x)$ obtaining a closed 1-form θ_x with values in the vector space $\bigwedge^2 T_x^*M$. Hence, we can define $\eta \in \Omega^0(\mathcal{F}_t; \bigwedge^2 \nu_t^*)$ on each fiber $\mathbf{t}^{-1}(x)$ to be the 0-form with values in the vector space $\bigwedge^2 T_x^*M$ defined by

$$\eta_g := \int_\gamma \theta_x,$$

where $\gamma : [0, 1] \rightarrow \mathbf{t}^{-1}(x)$ is any curve in the fiber joining 1_x to g . Since the \mathbf{t} -fiber is 1-connected and the form θ_x is closed, this does not depend on the choice of γ . We still need to check that η is smooth. For that it is enough to show that each $g_0 \in \Sigma$ has a neighborhood U for which there exists a smooth map $\gamma : U \times [0, 1] \rightarrow \Sigma$ such that, for all $g \in U$, the path $t \mapsto \gamma(g, t)$ is contained in the \mathbf{t} -fiber of g , it starts at $1_{\mathbf{t}(g)}$, and it ends at g . This can be shown by covering a fixed path γ_0 connecting $1_{\mathbf{t}(g_0)}$ to g_0 by submersion charts for \mathbf{t} .

Second proof of Theorem 14.29. The departing point of this second proof is a characterization of multiplicative forms as groupoid morphisms. To state it we need the tautological k -form $\theta_k \in \Omega^k(\bigwedge^k T^*M)$ generalizing the Liouville 1-form: if $\alpha \in T^*M$ and $v_1, \dots, v_k \in T_\alpha(\bigwedge^k T^*M)$ it is given by

$$(\theta_k)_\alpha(v_1, \dots, v_k) := \alpha(dp(v_1), \dots, dp(v_k)).$$

The forms θ_k , like the Liouville 1-form, are characterized by the property that $\alpha^*\theta_k = \alpha$, for all $\alpha \in \Omega^k(M)$.

We also need to generalize the bundle map $\sigma_\Omega : A \rightarrow T^*M$ from Theorem 14.10 to higher degree. For a multiplicative form $\Omega \in \Omega^k(\mathcal{G})$, define

$$\sigma_\Omega : A \rightarrow \bigwedge^{k-1} T^*M, \quad \alpha \mapsto -\mathbf{u}^*(i_\alpha\Omega).$$

Finally, we will make use of the Lie groupoid structure on $\bigoplus^k T\mathcal{G} \rightrightarrows \bigoplus^k TM$ from Example 13.21 and of its Lie algebroid $\bigoplus^k TA \rightrightarrows \bigoplus^k TM$ from Example 13.53.

Proposition 14.32. *For $k \geq 1$, a form $\Omega \in \Omega^k(\mathcal{G})$ is multiplicative if and only if the map*

$$\begin{array}{ccc} \bigoplus^k T\mathcal{G} & \xrightarrow{\bar{\Omega}} & (\mathbb{R}, +) \\ \Downarrow & & \downarrow \\ \bigoplus^k TM & \longrightarrow & \{*\} \end{array} \quad (v_1, \dots, v_k) \mapsto \Omega(v_1, \dots, v_k)$$

is a Lie groupoid morphism. In this case, the induced Lie algebroid morphism

$$\bar{\omega}_A := \text{Lie}(\bar{\Omega}) : \bigoplus^k TA \rightarrow \mathbb{R}$$

corresponds to a k -form on the total space of the bundle A given by

$$(14.10) \quad \omega_A := -d(\sigma_\Omega^*\theta_{k-1}) - \sigma_{d\Omega}^*(\theta_k) \in \Omega^k(A).$$

Proof. Using the definition of the multiplication $\bigoplus^k \mathbf{dm}$ in $\bigoplus^k T\mathcal{G}$, the multiplicative condition can be rewritten as

$$\bar{\Omega}\left(\bigoplus^k \mathbf{dm}(V, W)\right) = \bar{\Omega}(V) + \bar{\Omega}(W), \quad \forall (V, W) \in \left(\bigoplus^k T\mathcal{G}\right)^{(2)},$$

which just means that $\bar{\Omega}$ is a groupoid morphism.

Let us explain the second part for 2-forms. We need to find the map

$$\text{Lie}(\bar{\Omega}) : \bigoplus^2 TA \rightarrow \mathbb{R}, \quad X \mapsto d_{(v,w)}\bar{\Omega}(X), \quad X \in \left(\bigoplus^2 TA\right)_{(v,w)}.$$

Sections of TA are generated by the linear and core sections — see Example 13.53 — of the form $d\alpha$ and $\hat{\alpha}$, for $\alpha \in \Gamma(A)$. It follows that sections of $\bigoplus^2 TA$ are generated by sections of the following type:

$$d\alpha \oplus d\alpha, \quad \hat{\alpha} \oplus 0, \quad 0 \oplus \hat{\alpha}.$$

We then find for any $\alpha \in \Gamma(A)$ that

$$\begin{aligned} d_{(v,w)}\overline{\Omega}(\widehat{\alpha} \oplus 0) &= (i_\alpha\Omega)(w) = -\sigma_\Omega(\alpha)(w), \\ d_{(v,w)}\overline{\Omega}(0 \oplus \widehat{\alpha}) &= -(i_\alpha\Omega)(v) = \sigma_\Omega(\alpha)(v), \\ d_{(v,w)}\overline{\Omega}(d\alpha \oplus d\alpha) &= (di_\alpha\Omega + i_\alpha d\Omega)(v, w) \\ &= -(d\sigma(\alpha) + \sigma_{d\Omega}(\alpha))(v, w) \end{aligned}$$

and then (14.10) follows from the definition of the tautological forms. \square

We can now turn to the proof. Starting with the Lie algebroid isomorphism $\sigma : A \rightarrow T^*M$, we define a 2-form ω_A on the total space of the bundle $A \rightarrow M$ by

$$\omega_A := -d(\sigma^*\theta_1) = d(\sigma^*\omega_{\text{can}}) \in \Omega^2(A).$$

We can view ω_A as a vector bundle map

$$\begin{array}{ccc} \bigoplus^2 TA & \xrightarrow{\overline{\omega}_A} & \mathbb{R} \\ \downarrow & & \downarrow \\ \bigoplus^2 TM & \longrightarrow & \{*\} \end{array}$$

Since $\sigma : A \rightarrow T^*M$ is a Lie algebroid morphism it follows that $\overline{\omega}_A$ is a Lie algebroid morphism to the abelian Lie algebra \mathbb{R} :

Lemma 14.33. $\overline{\omega}_A : \bigoplus^2 TA \rightarrow \mathbb{R}$ is a Lie algebroid map.

The proof of this lemma is left for the end of the proof.

Since $\Sigma \rightrightarrows M$ has 1-connected \mathfrak{t} -fibers, the groupoid $T\Sigma \rightrightarrows TM$ also has 1-connected \mathfrak{t} -fibers, and the same holds for the direct sum $\bigoplus^2 T\Sigma$. Hence, by the previous lemma, we can apply Lie’s Second Theorem to obtain a Lie groupoid morphism

$$\overline{\Omega} : \bigoplus^2 T\Sigma \rightarrow \mathbb{R}.$$

We claim that the map $(X, Y) \mapsto \overline{\Omega}(X, Y)$ is bilinear and skew-symmetric:

$$\begin{aligned} \overline{\Omega}(aV, W) &= a\overline{\Omega}(V, W), \\ \overline{\Omega}(V_1 + V_2, W) &= \overline{\Omega}(V_1, W) + \overline{\Omega}(V_2, W), \\ \overline{\Omega}(V, W) &= -\overline{\Omega}(W, V), \end{aligned}$$

so that, by Proposition 14.32, we have a multiplicative 2-form $\Omega \in \Omega^2(\Sigma)$. The proofs of these conditions are all of the same sort, so we give the details only for the last one. For that we observe that the map

$$I : \bigoplus^2 T\Sigma \rightarrow \bigoplus^2 T\Sigma, \quad I(V, W) := (W, V),$$

is a groupoid morphism whose induced Lie algebroid map is

$$I_* : \bigoplus^2 TA \rightarrow \bigoplus^2 TA, \quad I_*(\alpha, \beta) = (\beta, \alpha).$$

Then $-\bar{\Omega} \circ I : \bigoplus^2 T\Sigma \rightarrow \mathbb{R}$ is also a groupoid morphism and the induced Lie algebroid morphism is

$$(-\bar{\Omega} \circ I)_* = -\bar{\omega}_A \circ I_* = \bar{\omega}_A.$$

By uniqueness in Lie’s Second Theorem we must have $\bar{\Omega} = -\bar{\Omega} \circ I$, which is precisely the skew-symmetry. For the other properties one proceeds similarly replacing I by the Lie groupoid morphisms:

$$\begin{aligned} \bigoplus^2 T\Sigma &\rightarrow \bigoplus^2 T\Sigma, & (V, W) &\mapsto (aV, W), \\ \bigoplus^3 T\Sigma &\rightarrow \bigoplus^2 T\Sigma, & (V_1, V_2, W) &\mapsto (V_1 + V_2, W). \end{aligned}$$

The Lie groupoid morphism $\bar{\Omega}$ differentiates to the Lie algebroid map $\bar{\omega}_A = \text{Lie}(\bar{\Omega}) : \bigoplus^2 TA \rightarrow \mathbb{R}$. By Proposition 14.32, we have

$$\omega_A = -\sigma^* d\theta_1 = -\sigma_{\Omega}^* d\theta_1 - \sigma_{d\Omega}^* \theta_2.$$

The properties of the tautological forms imply that

$$\sigma = \sigma_{\Omega}, \quad \sigma_{d\Omega} = 0.$$

This follows from the following exercise:

Exercise 14.34. Consider two vector bundle maps $\sigma_{k-1} : A \rightarrow \bigwedge^{k-1} T^*M$ and $\sigma_k : A \rightarrow \bigwedge^k T^*M$. If

$$\sigma_{k-1}^* d\theta_{k-1} + \sigma_k^* \theta_k = 0,$$

show that $\sigma_{k-1} = 0$ and $\sigma_k = 0$.

To show that Ω is closed, we again apply Proposition 14.32 to the multiplicative 3-form $d\Omega$. Viewed as a Lie groupoid morphism $\overline{d\Omega}$, since $\sigma_{d\Omega} = 0$, the induced Lie algebroid morphism is 0. Hence, by the uniqueness in Lie’s Second Theorem, we obtain that $d\Omega = 0$.

Finally, the nondegeneracy follows, as before, from the fact that $\sigma_{\Omega} = \sigma$ is an isomorphism — see the last part of the proof of Proposition 14.30. So Ω is a multiplicative symplectic form. Uniqueness follows again from the uniqueness in Lie’s Second Theorem.

Proof of the Lemma 14.33. We need to check that the pullback map $(\bar{\omega}_A)^* : \Omega^\bullet(\mathbb{R}) \rightarrow \Omega^\bullet(\bigoplus^2 TA)$ commutes with differentials. In degree 0,

this is just commutation with anchors, which is obvious. In degree 1, since the differential in \mathbb{R} is 0, this just amounts to

$$(14.11) \quad \bar{\omega}_A([X, Y]) = \mathcal{L}_X \bar{\omega}_A(Y) - \mathcal{L}_Y \bar{\omega}_A(X), \quad \forall X, Y \in \Gamma\left(\bigoplus^2 TA\right).$$

We only need to check this equation on pairs of sections of the type

$$d\alpha \oplus d\alpha, \quad \hat{\alpha} \oplus 0, \quad 0 \oplus \hat{\alpha}.$$

In the calculations below, we will regard 1-forms and 2-forms on M as functions on TM and $TM \oplus TM$, respectively.

- If $X = \hat{\alpha} \oplus 0$ and $Y = \hat{\beta} \oplus 0$, or the other way around, the bracket vanishes and so does the right-hand side.

- If $X = \hat{\alpha} \oplus 0$ and $Y = 0 \oplus \hat{\beta}$, the bracket still vanishes and the right-hand side of (14.11) becomes

$$i_{\rho(\alpha)}\sigma(\beta) + i_{\rho(\beta)}\sigma(\alpha) = \pi(\sigma(\alpha), \sigma(\beta)) + \pi(\sigma(\beta), \sigma(\alpha)) = 0,$$

where we used that $\sigma : A \rightarrow T^*M$ preserves anchors; i.e., $\rho = \pi^\# \circ \sigma$.

- If $X = d\alpha \oplus d\alpha$ and $Y = \hat{\beta} \oplus 0$, we find that

$$[X, Y] = [\widehat{\alpha, \beta}]_A \oplus 0,$$

so the left side of (14.11) gives

$$\bar{\omega}_A([X, Y]) = \text{pr}_2^* \sigma([\alpha, \beta]_A) = \text{pr}_2^* [\sigma(\alpha), \sigma(\beta)]_\pi,$$

where we used that $\sigma : A \rightarrow T^*M$ preserves brackets and we pulled back a function along $\text{pr}_2 : \bigoplus^2 TM \rightarrow TM$. On the other hand, the right-hand side of (14.11) becomes

$$\begin{aligned} \mathcal{L}_X \bar{\omega}_A(Y) - \mathcal{L}_Y \bar{\omega}_A(X) &= \text{pr}_2^* (\mathcal{L}_{\rho(\alpha)}\sigma(\beta) - i_{\rho(\beta)}d\sigma(\alpha)) \\ &= \text{pr}_2^* (\mathcal{L}_{\rho(\alpha)}\sigma(\beta) - \mathcal{L}_{\rho(\beta)}\sigma(\alpha) + \text{di}_{\rho(\beta)}\sigma(\alpha)) \\ &= \text{pr}_2^* (\mathcal{L}_{\pi^\#(\sigma(\alpha))}\sigma(\beta) - \mathcal{L}_{\pi^\#(\sigma(\beta))}\sigma(\alpha) - d\pi(\sigma(\alpha), \sigma(\beta))) \\ &= \text{pr}_2^* ([\sigma(\alpha), \sigma(\beta)]_\pi) \end{aligned}$$

where we used the definition of the bracket $[\cdot, \cdot]_\pi$.

- Finally for two sections $X = d\alpha \oplus d\alpha$ and $Y = d\beta \oplus d\beta$, we obtain that the bracket is

$$[X, Y] = d[\alpha, \beta]_A \oplus d[\alpha, \beta]_A,$$

so the left-hand side of (14.11) is

$$\bar{\omega}_A([X, Y]) = d(\sigma[\alpha, \beta]_A) = d([\sigma(\alpha), \sigma(\beta)]_\pi).$$

For the right side of (14.11) we now find

$$\begin{aligned} \mathcal{L}_X \bar{\omega}_A(Y) - \mathcal{L}_Y \bar{\omega}_A(X) &= d\mathcal{L}_{\rho(\alpha)}\sigma(\beta) - d\mathcal{L}_{\rho(\beta)}\sigma(\alpha) \\ &= d(\mathcal{L}_{\rho(\alpha)}\sigma(\beta) - \mathcal{L}_{\rho(\beta)}\sigma(\alpha) - d\pi(\sigma(\alpha), \sigma(\beta))) \\ &= d([\sigma(\alpha), \sigma(\beta)]_\pi) \end{aligned}$$

where we used again that $\sigma : A \rightarrow T^*M$ is a Lie algebroid isomorphism. So the equation holds and this finishes the proof of the lemma. \square

Remark 14.35. The previous proof can also be used to obtain an explicit formula for the symplectic structure from Theorem 14.29 on Σ . To present the explicit formula, we need a bit of terminology. For any $g \in \Sigma$ we can find a smooth path $\gamma : [0, 1] \rightarrow \mathfrak{t}^{-1}(x)$, $x = \mathfrak{t}(g)$, joining $\gamma(0) = 1_x$ to $\gamma(1) = g$. We associate to γ the A -path

$$a : [0, 1] \rightarrow A, \quad a(t) := dL_{\gamma(t)^{-1}}(\dot{\gamma}(t)).$$

We will say that a is an A -path representing g .

Similarly, a tangent vector $V \in T_g\Sigma$ will be represented by a TA -path (a, v) . In such a pair, $a : [0, 1] \rightarrow A$ is an A -path representing the base point $g \in \Sigma$ of V and

$$v : [0, 1] \rightarrow TA, \quad t \mapsto v(t) \in T_{a(t)}A$$

is obtained as follows. First, we choose a path $\varepsilon \mapsto g_\varepsilon$ with

$$V = \left. \frac{d}{d\varepsilon} \right|_{\varepsilon=0} g_\varepsilon.$$

Then each g_ε can be connected to the unit at $x_\varepsilon = \mathfrak{t}(g_\varepsilon)$ by a smooth path $\gamma_\varepsilon : [0, 1] \rightarrow \mathfrak{t}^{-1}(x_\varepsilon)$ as above, such that $\gamma(\varepsilon, t)$ is smooth. Consider the corresponding family of A -paths $a_\varepsilon : [0, 1] \rightarrow A$. Then V is represented by $a := a_0$ together with the variation of this family:

$$v : [0, 1] \rightarrow TA, \quad t \mapsto \left. \frac{d}{d\varepsilon} \right|_{\varepsilon=0} a_\varepsilon(t) \in T_{a(t)}A.$$

With this terminology, the symplectic structure on Σ is given by

$$(14.12) \quad \Omega_g(V, W) := \int_0^1 (\sigma^* \omega_{\text{can}})_{a(t)}(v(t), w(t)) dt,$$

where (a, v) and (a, w) are TA -paths representing $V, W \in T_g\Sigma$.

This formula originates from the cotangent path space approach — see Remark 14.51. It also follows from the second proof combined with a general formula for integrating 1-cocycles. Given a Lie algebroid morphism $c : B \rightarrow \mathbb{R}$, the corresponding Lie groupoid morphism $C : \mathcal{G} \rightarrow \mathbb{R}$, where \mathcal{G} is a Lie

groupoid with 1-connected \mathfrak{t} -fibers, is given by

$$(14.13) \quad C(g) = \int_0^1 c(a(t))dt,$$

where $a : [0, 1] \rightarrow B$ is a B -path representing g , as explained above.

Exercise 14.36. Prove formula (14.12), by applying (14.13) to $\bar{\omega}_A = \sigma^*d\theta_1$.

Remark 14.37. The first proof of Theorem 14.29 was extracted from the general machinery developed in [11]. The second proof is due to Bursztyn, Cabrera, and Ortiz [22, 23]. It is an improvement of the original proof of Mackenzie and Xu [115] and is part of a general program of integrating *infinitesimally* multiplicative structures, with the case of arbitrary tensors carried out in [24].

14.4. Symplectic groupoid actions

Definition 14.38. Let $(\Sigma, \Omega) \rightrightarrows M$ be symplectic groupoid, and let (S, ω) be a symplectic manifold. A left groupoid action of Σ along a map $\mu : S \rightarrow M$ is called a **symplectic groupoid action** if it satisfies

$$(14.14) \quad \mathcal{A}^*\omega = \text{pr}_1^*\Omega + \text{pr}_2^*\omega,$$

where $\mathcal{A} : \Sigma \times_M S \rightarrow S$ denotes the action and $\text{pr}_1 : \Sigma \times_M S \rightarrow \Sigma$ and $\text{pr}_2 : \Sigma \times_M S \rightarrow S$ denote the projections.

We also call (S, ω) a **Hamiltonian (Σ, Ω) -space** and $\mu : S \rightarrow M$ the **moment map**. We define right actions in a similar way.

Example 14.39. For any symplectic groupoid $(\Sigma, \Omega) \rightrightarrows M$, the multiplication, viewed as a left action of Σ on itself, is a symplectic groupoid action along $\mathfrak{t} : \Sigma \rightarrow M$. 

Example 14.40. Let G be a Lie group, and consider the symplectic groupoid $(G \times \mathfrak{g}^*, \Omega) \rightrightarrows \mathfrak{g}^*$ from Example 14.7. Then symplectic groupoid actions of $G \times \mathfrak{g}^*$ are the same as G -Hamiltonian spaces (S, ω, μ) . When G is connected, this follows from Proposition 14.45 and Problem 13.7 — the general case is left as an exercise.

Example 14.41. Consider an integrable lattice $\Lambda \subset T^*M$, with corresponding symplectic groupoid

$$(\mathcal{T}_\Lambda, \omega_\Lambda) \rightrightarrows M.$$

By Proposition 12.30, any proper Lagrangian fibration $\mu : (S, \omega) \rightarrow M$ inducing Λ is a Hamiltonian \mathcal{T}_Λ -space. 

As suggested by the terminology “Hamiltonian (Σ, Ω) -space”, the idea behind this notion is based on replacing:

- duals of Lie algebras by general Poisson manifolds,
- moment maps by Poisson maps,
- Hamiltonian actions by symplectic groupoid actions.

The next proposition supports this philosophy. To state it we recall from Example 13.49 that a Lie groupoid action of $\Sigma \rightrightarrows M$ on a map $\mu : S \rightarrow M$ induces a Lie algebroid action $\mathfrak{a} : \Gamma(A) \rightarrow \mathfrak{X}(S)$.

Proposition 14.42. *Consider a symplectic groupoid (Σ, Ω) with induced Poisson structure π on M . For any symplectic groupoid action of (Σ, Ω) with moment map $\mu : (S, \omega) \rightarrow M$, one has the following:*

- (i) $\mu : (S, \omega) \rightarrow (M, \pi)$ is a complete Poisson map.
- (ii) The induced Lie algebroid action $\mathfrak{a} : \Gamma(A) \rightarrow \mathfrak{X}(S)$ satisfies

$$\mu^*(\sigma_\Omega(\alpha)) = i_{\mathfrak{a}(\alpha)}\omega.$$

Notice that μ is Σ -equivariant by the definition of a groupoid action. Note also that the moment map condition in (ii) says that the induced infinitesimal action \mathfrak{a} is identified via the isomorphism $\sigma_\Omega : A \rightarrow T^*M$ with the infinitesimal action $\Omega^1(M) \rightarrow \mathfrak{X}(S)$ associated to the Poisson map μ — see Definition 12.2.

Proof. In this proof we identify $M \equiv \mathbf{u}(M) \subset \Sigma$, and so we write $\mathbf{u}(x) = x$.

For (ii) we have to show that, for any $v \in T_p S$ and any $\alpha \in A_x$, where $x = \mu(p)$, one has

$$-\Omega_x(\alpha, d\mu(v)) = \omega_p(\mathfrak{a}_p(\alpha), v).$$

As in (13.5), the infinitesimal action is given by differentiating the map

$$\mathbf{t}^{-1}(x) \rightarrow S, \quad g \mapsto g^{-1}p = \mathcal{A}(\boldsymbol{\iota}(g), p).$$

In other words,

$$\mathfrak{a}_p(\alpha) = d_{(x,p)}\mathcal{A}(d\boldsymbol{\iota}(\alpha), 0_p).$$

On the other hand, because units act trivially, one also has the identity

$$v = d_{(x,p)}\mathcal{A}(d\mu(v), v), \quad \forall v \in T_p S.$$

Inserting these two identities in the multiplicativity equation (14.14), we find

$$\omega_p(\mathfrak{a}_p(\alpha), v) = \Omega_x(d\boldsymbol{\iota}(\alpha), d\mu(v)).$$

Since $\boldsymbol{\iota}^*\Omega = -\Omega$ and $\boldsymbol{\iota} \circ \mathbf{u} = \mathbf{u}$, it follows that

$$\omega_p(\mathfrak{a}_p(\alpha), v) = -\Omega_x(\alpha, d\boldsymbol{\iota} d\mu(v)) = -\Omega_x(\alpha, d\mu(v)),$$

i.e., precisely the desired identity.

For (i) we denote by π_ω the inverse of ω . We have to show that

$$\pi^\sharp = d\mu \circ \pi_\omega^\sharp \circ (d\mu)^*.$$

This follows because σ_Ω is invertible and the commutative diagram

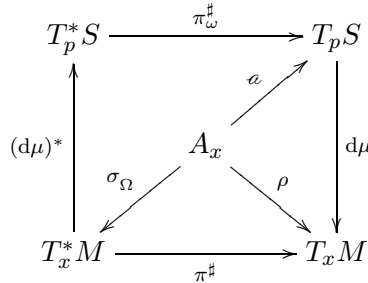

gives

$$d\mu \circ \pi_\omega^\sharp \circ (d\mu)^* \circ \sigma_\Omega = d\mu \circ \mathfrak{a} = \rho = \pi^\sharp \circ \sigma_\Omega.$$

The big triangle in the diagram is commutative by part (ii), the bottom triangle is commutative because σ_Ω is a Lie algebroid map, and the right triangle is commutative because \mathfrak{a} is an action.

For the completeness of the action, start with $H \in C^\infty(M)$ such that $X_H \in \mathfrak{X}(M)$ is complete, and we show that $X_{H \circ \mu}$ is complete. For that we notice that

$$X_{H \circ \mu} = \mathfrak{a}(\alpha), \quad \text{where } \alpha = \sigma_\Omega^{-1}(dH) \in \Gamma(A),$$

and $\rho(\alpha) = X_H \in \mathfrak{X}(M)$ is complete. By Proposition 13.37, we know that $\overleftarrow{\alpha} \in \mathfrak{X}(\Sigma)$ is a complete vector field. Next, note that the flow of $\mathfrak{a}(\alpha)$ is given by

$$\phi_{\mathfrak{a}(\alpha)}^t(p) = \phi_{\overleftarrow{\alpha}}^t(\mu(p))^{-1} \cdot p,$$

because the right-hand side gives integral curves of $\mathfrak{a}(\alpha)$. Therefore $\mathfrak{a}(\alpha) = X_{H \circ \mu}$ is complete. □

The previous proposition allows one to carry on with the philosophy that symplectic groupoid actions provide a general Poisson geometric framework for moment map theories. For instance, one obtains a generalization of symplectic reduction as follows.

As in the classical case, to ensure smooth quotients we will consider groupoid actions of $\Sigma \rightrightarrows M$ on $\mu : S \rightarrow M$ that are free and proper, where

- free: $g \cdot p = p \Rightarrow g = 1_{\mu(p)}$,
- proper: $(\mathcal{A}, \text{pr}_2) : \Sigma \times_M S \rightarrow S \times S$ is a proper map.

So let (Σ, Ω) be a symplectic groupoid and let $\mu : (S, \omega) \rightarrow M$ be a free and proper Hamiltonian (Σ, Ω) -space. Then:

- (i) For each $x \in S$, each of the spaces

$$S //_x \Sigma := \mu^{-1}(x) / \Sigma_x$$

is smooth and carries a canonical symplectic structure ω_x , uniquely determined by the condition that its pullback to $\mu^{-1}(x)$ coincides with the restriction of ω .

- (ii) The quotient

$$N := S / \Sigma$$

is smooth and carries a unique Poisson structure π_N making the canonical projection

$$p : (S, \omega) \rightarrow (N, \pi_N)$$

into a Poisson submersion.

- (iii) The symplectic leaves of (N, π_N) can be identified with the connected components of the symplectic quotients $S //_x \Sigma$.

For instance, this theory allows one to treat certain non-Hamiltonian symplectic actions of a Lie group on a symplectic manifold as if they were Hamiltonian actions. This is illustrated in the following example.

Example 14.43 (Cylinder-valued moment maps). Denote by \mathfrak{t} an abelian Lie algebra and let $\Lambda \subset \mathfrak{t}$ be a full rank lattice, so that we have a torus

$$\mathbb{T}_\Lambda := \mathfrak{t} / \Lambda.$$

Consider a symplectic torus action of \mathbb{T}_Λ on a symplectic manifold (S, ω) with infinitesimal action $\mathfrak{a} : \mathfrak{t} \rightarrow \mathfrak{X}(S)$. Fixing a base point $p_0 \in S$, we introduce the group homomorphism

$$\Phi : \pi_1(S, p_0) \rightarrow \mathfrak{t}^*, \quad \Phi([\gamma])(v) := \int_\gamma i_{\mathfrak{a}(v)} \omega \quad (v \in \mathfrak{t}).$$

Notice that the \mathbb{T}_Λ -action is Hamiltonian if and only if the image of this homomorphism is trivial. We will obtain a (groupoid) Hamiltonian action by “killing” this image, so we make the following assumption:

- $\Phi(\pi_1(S, p_0)) \subset \mathfrak{t}^*$ is a discrete subgroup.

Then we can introduce the cylinder

$$C = \mathfrak{t}^* / \Phi(\pi_1(S, p_0)),$$

as well as the moment map

$$\mu : S \rightarrow C, \quad p \mapsto \left[v \mapsto \int_\gamma i_{\mathfrak{a}(v)} \omega \right]$$

where $\gamma : [0, 1] \rightarrow S$ is any path with $\gamma(0) = p_0$ and $\gamma(1) = p$.

Exercise 14.44. Show that $\mu : (S, \omega) \rightarrow (C, 0)$ is a Poisson map.

Since $T^*C = C \times \mathfrak{t}$ and the slices $\{c\} \times \mathfrak{t}$ are Lagrangian submanifolds for the canonical symplectic form, we can view $\Lambda \subset \mathfrak{t}$ as defining an integrable affine structure on C . We obtain a symplectic torus bundle over C with fiber \mathbb{T}_Λ :

$$\text{pr} : (\mathcal{T}_\Lambda, \omega_\Lambda) \rightarrow C.$$

This is a symplectic groupoid and admits a symplectic groupoid action

$$\begin{array}{ccc} (\mathcal{T}_\Lambda, \omega_\Lambda) & \curvearrowright & (S, \omega) \\ & \searrow & \downarrow \mu \\ & & C \end{array}$$

where on each fiber $\mu^{-1}(c)$ one takes the original \mathbb{T}_Λ -action.

The discussion above then shows that one can perform symplectic reduction for the cylinder-valued moment map $\mu : S \rightarrow C$. If the action of \mathbb{T}_Λ on $\mu^{-1}(c)$ is free one obtains the symplectic quotient

$$S //_c \mathcal{T}_\Lambda := \mu^{-1}(c) / \mathbb{T}_\Lambda. \quad \text{🐟}$$

The following converse of Proposition 14.42 gives an infinitesimal characterization of the multiplicativity condition (14.14) for symplectic groupoid actions.

Proposition 14.45. *Let $(\Sigma, \Omega) \rightrightarrows M$ be a symplectic groupoid with connected \mathfrak{t} -fibers, and let (S, ω) be a symplectic manifold. An action of Σ on $\mu : S \rightarrow M$ is a symplectic groupoid action if and only if the following moment map condition holds:*

$$\mu^*(\sigma_\Omega(\alpha)) = i_{\mathcal{A}(\alpha)}\omega, \quad \forall \alpha \in \Gamma(A).$$

Proof. We consider the action groupoid $\tilde{\Sigma} = \Sigma \times S \rightrightarrows S$ and we rewrite the multiplicativity condition as the vanishing of the closed multiplicative form on $\tilde{\Sigma}$:

$$\tilde{\Omega} := \text{pr}_1^* \Omega - \mathcal{A}^* \omega + \text{pr}_2^* \omega.$$

The multiplicativity of $\text{pr}_1^* \Omega$ follows because $\text{pr}_1 : \tilde{\Sigma} \rightarrow \Sigma$ is a groupoid morphism. Since \mathcal{A} and pr_2 are the target and source of $\tilde{\Sigma}$, it follows that $-\mathcal{A}^* \omega + \text{pr}_2^* \omega$ is even multiplicatively exact.

Note that the \mathfrak{t} -fibers of $\tilde{\Sigma}$ are connected, as they can be identified to those of Σ . Therefore we can apply the proof of the uniqueness part in Theorem 14.29, which gives that $\tilde{\Omega} = 0$ if and only if $\sigma_{\tilde{\Omega}} = 0$. Note that nondegeneracy was not used there.

We show that $\sigma_{\tilde{\Omega}} = 0$. Notice that any element in the Lie algebroid \tilde{A} of $\tilde{\Sigma}$ is of the form $\tilde{\alpha} = (\alpha, 0_p)$, with $\alpha \in A_{\mu(p)}$. The differential of unit map $\tilde{\mathbf{u}}$ of $\tilde{\Sigma}$ is given by

$$d\tilde{\mathbf{u}}(v) = (d\mathbf{u} d\mu(v), v) \quad (v \in T_p S).$$

Therefore, using the assumption, we obtain

$$\begin{aligned} \sigma_{\tilde{\Omega}}(\tilde{\alpha})(v) &= -\left(\text{pr}_1^* \Omega - \mathcal{A}^* \omega + \text{pr}_2^* \omega\right)(\tilde{\alpha}, d\tilde{\mathbf{u}}(v)) \\ &= \sigma_{\Omega}(\alpha)(d\mu(v)) + \omega(-a_p(\alpha), v) = 0. \end{aligned} \quad \square$$

14.5. Hausdorffness issues

As discussed in Section 13.7, we also need to consider the context of non-Hausdorff symplectic groupoids and non-Hausdorff symplectic realizations. We use the terminology from Section 13.7, and in particular Conventions 13.91 and 13.96. Additionally, we will also consider symplectic groupoid actions on possibly non-Hausdorff manifolds $\mu : (S, \omega) \rightarrow M$ — as before, the base M is always assumed to be Hausdorff.

Example 14.46. Consider $M = \mathbb{R}^3 \setminus \{0\}$ endowed with the foliation \mathcal{F} by horizontal planes $z = c$. Recall from Example 13.83 that the homotopy groupoid $\Pi(M, \mathcal{F}) \rightrightarrows \mathbb{R}^3 \setminus \{0\}$ is non-Hausdorff.

We endow each leaf of \mathcal{F} with the area form $\omega = dx \wedge dy$, obtaining a regular Poisson structure π on M . It is not difficult to see that the following is a non-Hausdorff symplectic groupoid integrating (M, π) :

$$(14.15) \quad \begin{aligned} \Sigma &:= \Pi(M, \mathcal{F}) \times \mathbb{R} \rightrightarrows \mathbb{R}^3 \setminus \{0\}, \\ \Omega &:= \mathbf{t}^* \omega - \mathbf{s}^* \omega + (\mathbf{t}^* dz - \mathbf{s}^* dz) \wedge dt, \end{aligned}$$

where Σ is the product of $\Pi(M, \mathcal{F}) \rightrightarrows M$ with the group $(\mathbb{R}, +)$. Actually, Σ can be identified with the Poisson homotopy groupoid of (M, π) :

Exercise 14.47. Using that $\mathbf{t} : (\Sigma, \Omega) \rightarrow (M, \pi)$ is a complete symplectic realization, construct a groupoid isomorphism between $\Pi(M, \pi)$ and Σ .

On the other hand, the holonomy groupoid can be identified with the submersion groupoid of $\text{pr}_3 : M \rightarrow \mathbb{R}$:

$$\text{Hol}(M, \mathcal{F}) \simeq M \times_{\mathbb{R}} M = \{(p, q) \in M \times M : \text{pr}_3(p) = \text{pr}_3(q)\}.$$

The same formula (14.15) makes $\text{Hol}(M, \mathcal{F}) \times \mathbb{R} \rightrightarrows M$ into a Hausdorff symplectic Lie groupoid, which still integrates (M, π) . 

Example 14.48. We can also turn the examples of bundles of Lie algebras of Douady and Lazard, mentioned in Example 13.82, into Poisson manifolds. Consider the associated fiberwise linear Poisson structure (A^*, π_A) . Let

$\mathcal{G} \rightarrow M$ be a bundle of Lie groups integrating A . By Example 14.24, a symplectic groupoid integrating π_A is $(T^*\mathcal{G}, \Omega) \rightrightarrows A^*$.

As discussed in Example 13.82, the bundle of Lie algebras (13.13) can be integrated by two bundles of Lie groups, one Hausdorff and one not. So one obtains two symplectic Lie groupoids, one Hausdorff and one not. The second one has 1-connected \mathfrak{t} -fibers and so, as we will see later, it can be identified with the Poisson homotopy groupoid of (A^*, π_A) .

Recall that the second bundle of Lie algebras $B \rightarrow \mathbb{R}$ given in (13.14) does not admit Hausdorff bundles of Lie groups integrating it. This gives a Poisson manifold (B^*, π_B) which is integrable but does not admit any Hausdorff integration, due to the following:

Exercise 14.49. Let $(\Sigma, \Omega) \rightrightarrows B^*$ be a symplectic Lie groupoid with connected \mathfrak{t} -fibers integrating π_B . If $Z \subset B^*$ is the zero section, show that $\mathfrak{t}^{-1}(Z)$ is a bundle of Lie groups integrating the bundle of Lie algebras B .



In the non-Hausdorff setting, with our conventions, the results discussed so far in this chapter need to be adjusted as follows:

- The first properties of symplectic groupoids, i.e., Proposition 14.9, Theorem 14.10, as well as the uniqueness part of Theorem 14.29, require no change at all, and neither does the auxiliary Proposition 14.30.

- The first properties of symplectic groupoid actions from Proposition 14.42 hold, except that the completeness in item (i) should be removed. Indeed, we do not define the notion of completeness of arbitrary Poisson maps in the non-Hausdorff setting.

- The properties of symplectic groupoid actions from Proposition 14.45 also hold. However the proof requires a closer inspection, as we explain now. In the notation from the proof of Proposition 14.45, the action groupoid $\tilde{\Sigma} := \Sigma \times S \rightrightarrows S$ is over a non-Hausdorff base, and therefore we need to review the argument. The form $\tilde{\Omega} \in \Omega^2(\tilde{\Sigma})$ is still multiplicative and closed. The computation there shows that $\sigma_{\tilde{\Omega}} = 0$. The relation (C0) from Proposition 14.30 is a consequence of multiplicativity and makes no use of Hausdorffness. Hence $\tilde{\Omega}$ is horizontal for the projection $\text{pr}_2 : \Sigma \times S \rightarrow S$; i.e., $i_V \tilde{\Omega} = 0$, for all $V \in \text{Ker } d\text{pr}_2$. Since $\tilde{\Omega}$ is closed, Cartan's formula implies that $\mathcal{L}_V \tilde{\Omega} = 0$, for all $V \in \Gamma(\text{Ker } d\text{pr}_2)$. Note that the fibers of pr_2 are Hausdorff, and so $\tilde{\Omega} = \text{pr}_2^* \tau$ for some $\tau \in \Omega^2(S)$. Using again the multiplicativity argument (14.5), one concludes that $\tilde{\Omega} = 0$.

- Theorem 14.29 continues to hold in the non-Hausdorff setting. The second proof works without any modifications. The first proof can be made

to work also in the non-Hausdorff setting, with the appropriate modifications. The only issue arises from the use of a splitting of the exact sequence $\text{Ker } dt \hookrightarrow T\mathcal{G} \rightarrow \mathfrak{t}^*TM$. As explained in Remark 13.92 and illustrated by Example 14.74, such a splitting may fail to exist.

From now on, we allow for non-Hausdorff groupoids and non-Hausdorff symplectic realizations, unless otherwise specified.

14.6. The Poisson homotopy groupoid

Recall that the Poisson homotopy groupoid of a Poisson manifold (M, π) is

$$\Pi(M, \pi) := \frac{\text{cotangent paths}}{\text{cotangent path-homotopy}} \rightrightarrows M,$$

with multiplication given by concatenation of cotangent paths. From Section 13.6, we know that this is always a topological groupoid with 1-connected target fibers. Using the results from Section 14.3, we can now state:

Theorem 14.50. *For a Poisson manifold (M, π) the following are equivalent:*

- (i) *The cotangent Lie algebroid $(T^*M, [\cdot, \cdot]_\pi, \pi^\sharp)$ is integrable.*
- (ii) *There exists a symplectic groupoid integrating (M, π) .*
- (iii) *(M, π) admits a complete symplectic realization with connected fibers.*

In this case, the Poisson homotopy groupoid $\Pi(M, \pi) \rightrightarrows M$ has a smooth structure and a symplectic form Ω such that $(\Pi(M, \pi), \Omega)$ is a symplectic integration of (M, π) .

Remark 14.51. A different characterization for integrability of the Lie algebroid T^*M can be given using the exponential map of a contravariant connection ∇ on (M, π) . By the results in Section 11.4, there exists an open neighborhood $U \subset T^*M$ of the zero section on which the geodesic flow $\phi^t : U \rightarrow T^*M$ of ∇ is defined for all $t \in [0, 1]$. For each $\xi \in U$, $t \mapsto a_\xi(t) := \phi_X^t(\xi)$ is a cotangent path, and we define the *exponential map* of ∇ as

$$\exp_\nabla : U \rightarrow \Pi(M, \pi), \quad \exp_\nabla(\xi) := [a_\xi].$$

The items in the previous theorem are also equivalent to — see [42]:

- (iv) *There exists a neighborhood $U \subset T^*M$ of the zero section on which \exp_∇ is injective.*

One can apply this characterization of integrability to show that the condition in (iii) that the fibers are connected can be dropped.

The results in [42] provide an even more complete version of the previous theorem. By applying the general discussion on integrability of Lie

algebroids from Section 14.3, we can talk about $\Pi(M, \pi)$ being smooth independent of the existence of symplectic realizations, namely, with the quotient smooth structure induced from the Banach manifold of cotangent paths — as it appears in Theorem 13.80. When this happens, we know that $\Pi(M, \pi)$ will be a Lie groupoid with Lie algebroid isomorphic to $(T^*M, [\cdot, \cdot]_\pi, \pi^\sharp)$. In particular, the items in the previous theorem are also equivalent to the following:

- (v) $\Pi(M, \pi) \rightrightarrows M$ is smooth, in the sense that the smooth structure on the cotangent path space descends.

By looking at the construction in the proof below, one can check that the smooth structure on $\Pi(M, \pi) \rightrightarrows M$ from the statement of the theorem coincides with the one coming from the path space construction.

The Poisson homotopy groupoid $\Pi(M, \pi)$ has a beautiful description as an infinite-dimensional symplectic quotient, due to Cattaneo and Felder [32]. The space of *all* paths in T^*M is a symplectic manifold that may be interpreted as the cotangent bundle $T^*P(M)$ of the manifold of all paths in M . The space of cotangent paths $P(T^*M) \subset T^*P(M)$ is a coisotropic submanifold. Actually, the Poisson geometry on M gives rise to an infinite-dimensional Lie algebra \mathfrak{g} and a \mathfrak{g} -Hamiltonian action on $T^*P(M)$ with moment map $\mu : T^*P(M) \rightarrow \mathfrak{g}^*$ such that

$$\mu^{-1}(0) = P(T^*M).$$

Furthermore, the orbits of the action of \mathfrak{g} on this level set, i.e., the space of cotangent paths, are precisely the cotangent homotopy classes. Therefore, one obtains the symplectic quotient

$$\Pi(M, \pi) = \mu^{-1}(0)/\mathfrak{g}.$$

The resulting symplectic form Ω is the one appearing in Theorem 14.50. This also leads to the explicit formula (14.12).

Proof of Theorem 14.50. If (i) holds, then by Lie's First Theorem, T^*M can be integrated by a Lie groupoid with 1-connected target fibers. By Theorem 14.29, this groupoid can be made into a symplectic groupoid integrating (M, π) , so (i) \Rightarrow (ii). Theorem 14.10 gives the reverse implication (ii) \Rightarrow (i). Given a symplectic groupoid, the same theorem applied to the \mathfrak{t} -connected component of the identity shows that the target map is a complete symplectic realization with connected fibers. Hence, we obtain that (ii) \Rightarrow (iii).

We prove now (iii) \Rightarrow (ii). Consider a complete symplectic realization $\mu : (S, \omega) \rightarrow (M, \pi)$. We will make use of the general construction of homotopy

groupoids as discussed in Example 13.27 applied to the orbit foliation \mathcal{F} :

$$\Pi(S, \mathcal{F}) \rightrightarrows S, \quad \mathcal{F} = (\text{Ker } d\mu)^{\perp\omega}.$$

Theorem 12.24 implies that the operation of lifting of cotangent paths gives a bijection

$$(14.16) \quad \tau : \Pi(M, \pi) \times S \rightarrow \Pi(S, \mathcal{F}), \quad ([a], p) \mapsto [\tilde{\gamma}_a^p],$$

and, since the lift of the concatenation of two cotangent paths is the concatenation of their lifts, this is an isomorphism of groupoids. We will use the smooth structure on $\Pi(S, \mathcal{F})$ to obtain one on $\Pi(M, \pi)$ and, ultimately, we will make sure that τ becomes an isomorphism of Lie groupoids.

One of the central players in our argument is the projection from the homotopy groupoid of (M, \mathcal{F}) to the one of (M, π) arising from the previous bijection:

$$\begin{array}{ccc} \Pi(S, \mathcal{F}) & \xrightarrow{\Phi} & \Pi(M, \pi) \\ \downarrow \downarrow & & \downarrow \downarrow \\ S & \xrightarrow{\mu} & M \end{array} \quad \tau([a], p) \mapsto [a].$$

We will see that $\Pi(M, \pi)$ admits a smooth structure — necessarily unique — such that Φ is a submersion. The strategy is to think of Φ as a quotient map and to use the following:

Lemma 14.52. *Given a foliation \mathcal{K} on a possibly non-Hausdorff manifold P , the following are equivalent:*

- (i) *The space of leaves P/\mathcal{K} admits a smooth structure such that the projection $\text{pr} : P \rightarrow P/\mathcal{K}$ is a submersion.*
- (ii) *Through each point of P there passes a simple \mathcal{K} -transversal; i.e., $T \subset P$ which intersects each leaf transversally and at most once.*

In this case P/\mathcal{K} becomes a smooth manifold, possibly non-Hausdorff. Moreover, for each transversal $T \subset P$ as in (ii), $\text{pr}|_T : T \rightarrow \text{pr}(T)$ is a diffeomorphism onto an open set.

Therefore, we take a closer look at the fibers of Φ and we show the following:

- The fibers of Φ form a foliation \mathcal{K} on $\Pi(M, \mathcal{F})$.
- Through each point of $\Pi(M, \mathcal{F})$ there passes a simple \mathcal{K} -transversal.

The first item is more subtle. To prove it, we make use of the symplectic geometry to describe a distribution, which is involutive and whose integral

submanifolds are the fibers of Φ . This distribution will appear as the characteristic distribution of the multiplicatively exact, closed 2-form

$$\tilde{\Omega} = \mathbf{t}_{\mathcal{F}}^* \omega - \mathbf{s}_{\mathcal{F}}^* \omega \in \Omega^2(\Pi(M, \mathcal{F})).$$

Both items follow from the following lemma:

Lemma 14.53. *With the notation above, we have the following:*

- (1) *The kernel of $\tilde{\Omega}$ has constant rank, equal to that of $\text{Ker } d\mu$.*
- (2) *The fibers of Φ are the leaves of the foliation \mathcal{K} integrating $\text{Ker } \tilde{\Omega}$.*
- (3) *If $T \subset S$ is a simple transversal to $\text{Ker } d\mu$, then $\mathbf{s}_{\mathcal{F}}^{-1}(T)$ is a simple transversal to \mathcal{K} .*

Proof. To handle the tangent spaces of $\Pi(S, \mathcal{F})$ we make use of the fact that $(\mathbf{t}_{\mathcal{F}}, \mathbf{s}_{\mathcal{F}}) : \Pi(S, \mathcal{F}) \rightarrow S \times S$ is an immersion, which holds because the isotropy groups of $\Pi(S, \mathcal{F})$ are discrete. This allows one to identify the tangent spaces of $\Pi(S, \mathcal{F})$ with subspaces of the tangent spaces of $S \times S$:

$$(14.17) \quad \chi_g := d_g(\mathbf{t}_{\mathcal{F}}, \mathbf{s}_{\mathcal{F}}) : T_g \Pi(M, \mathcal{F}) \xrightarrow{\simeq} \mathcal{T}_g \subset T(S \times S).$$

To describe the subspaces \mathcal{T}_g we make use of the linear holonomy action of $\Pi(S, \mathcal{F})$ on its normal bundle $\nu = \nu(\mathcal{F}) = TS/\mathcal{F}$. This associates to each arrow $g : p \rightarrow q$ of $\Pi(S, \mathcal{F})$ the linear map

$$\text{Hol}_g^{\text{lin}} : \nu_p \rightarrow \nu_q,$$

which is induced by the differential of the holonomy Hol_g . It follows from Lemma 13.28 that this map is well-defined. The same lemma and the discussion following it imply that

$$\mathcal{T}_g = \{(w, v) \in T_q S \times T_p S : \text{Hol}_g^{\text{lin}}(\bar{v}) = \bar{w}\},$$

where $\bar{v} = v \text{ mod } \mathcal{F} \in \nu$. We give a more practical description of \mathcal{T}_g . Write $g = \tau([a], p)$, where a is a cotangent path. By Lemma 10.3, there exists a smooth family of functions $\{H_t\}_{t \in [0,1]}$, all supported in some compact set, such that $a(t) = dH_t|_{\gamma_a(t)}$. Then the parallel transport along a is given by the flow of $X_{H \circ \mu}$; i.e.,

$$\tilde{\gamma}_a^{p'}(t) = \phi_{X_{H \circ \mu}}^t(p'), \quad \forall p' \in \mu^{-1}(x), \quad \text{where } x = \mu(p).$$

We set $\phi := \phi_{X_{H \circ \mu}}^1$. We claim that

$$\text{Hol}_g^{\text{lin}}(\bar{v}) = \overline{d_p \phi(v)} \quad (v \in T_p S).$$

Indeed, the integral curves $\epsilon \mapsto \phi_{X_{H \circ \mu}}^{\epsilon}(p')$ are tangent to the leaves of \mathcal{F} . When p' stays in a small transversal T to \mathcal{F} , the end points of these curves stay in $\phi(T)$; i.e., $T \rightarrow \phi(T)$, $p' \mapsto \phi(p')$ describes the holonomy Hol_g . Therefore, we have that

$$\mathcal{T}_g = \{(w, v) \in T_q S \times T_p S : d_p \phi(v) - w \in T_q \mathcal{F}\}.$$

We claim that the kernel of $\tilde{\Omega}$ is mapped via (14.17) isomorphically to

$$(14.18) \quad \chi_g(\text{Ker } \tilde{\Omega}) = \{(d_p\phi(v), v) : v \in \text{Ker } d_p\mu\}.$$

Since

$$\tilde{\Omega} = \chi_g^*(\text{pr}_1^*\omega - \text{pr}_2^*\omega),$$

we have that $(w_1, v_1) \in \chi_g(\text{Ker } \tilde{\Omega})$ if and only if $d_p\phi(v_1) - w_1 \in T_q\mathcal{F}$ and

$$\omega_q(w_1, w_2) = \omega_p(v_1, v_2), \quad \forall (w_2, v_2) \text{ such that } d_p\phi(v_2) - w_2 \in T_q\mathcal{F},$$

where $p = \mathbf{s}_{\mathcal{F}}(g)$, $q = \mathbf{t}_{\mathcal{F}}(g)$. Taking $w_2 = 0$ and $v_2 \in T_p\mathcal{F}$ arbitrary, we conclude that $v_1 \in (T_p\mathcal{F})^{\perp\omega} = \text{Ker } d_p\mu$. Denote $u_1 = w_1 - d_p\phi(v_1)$. Now letting $w_2 := d_p\phi(v_2)$ and using that ϕ is a symplectomorphism, we obtain

$$0 = \omega_q(d_p\phi(v_1) + u_1, d_p\phi(v_2)) - \omega_p(v_1, v_2) = \omega_q(u_1, d_p\phi(v_2)).$$

Since v_2 was arbitrary and ω is nondegenerate, we obtain that $u_1 = 0$; i.e., $w_1 = d_p\phi(v_1)$. For the converse we have to check that $\omega_q(d_p\phi(v_1), w_2) = \omega_p(v_1, v_2)$ whenever $v_1 \in \text{Ker } d_p\mu$ and $u_2 := d_p\phi(v_2) - w_2 \in T_q\mathcal{F}$. This follows by a similar computation. This proves (14.18), and so $\tilde{\Omega}$ has the desired rank. Since $\tilde{\Omega}$ is also closed, (1) follows.

For (2), notice first that the fiber of Φ above a point $[a] \in \Pi(M, \pi)$ is the image of the map

$$i_a : \mu^{-1}(x) \rightarrow \Pi(S, \mathcal{F}), \quad p \mapsto [\tilde{\gamma}_a^p] \quad (x = \gamma_a(0)).$$

Since the μ -fibers are connected and have the same dimension as the rank of \mathcal{K} , it suffices to prove that each i_a is a smooth embedding tangent to \mathcal{K} . The smoothness i_a follows from smooth dependence of parameters of ODEs applied to the ODE defining lifts. On the other hand, since the composition of i_a with the submersion $\mathbf{s}_{\mathcal{F}} : \Pi(S, \mathcal{F}) \rightarrow S$ is the inclusion $\mu^{-1}(x) \hookrightarrow S$, i_a is indeed an embedding. To prove that $i_a : \mu^{-1}(x) \rightarrow \Pi(S, \mathcal{F})$ is tangent to $\text{Ker } \tilde{\Omega}$, notice that

$$(\mathbf{t}_{\mathcal{F}}, \mathbf{s}_{\mathcal{F}}) \circ i_a : \mu^{-1}(x) \rightarrow S \times S, \quad p \mapsto (\phi(p), p).$$

Finally, to check (3), let $T \subset S$ be a simple transversal to $\text{Ker } d\mu$. Then

$$\text{codim } \mathbf{s}_{\mathcal{F}}^{-1}(T) = \text{codim } T = \text{codim } \mathcal{K}.$$

For $g \in \mathbf{s}_{\mathcal{F}}^{-1}(T)$, applying χ_g to the intersection $\text{Ker } \tilde{\Omega} \cap T_g\mathbf{s}_{\mathcal{F}}^{-1}(T)$ we obtain elements $(d\phi(v), v) \in \mathcal{T}_g$ with $v \in \text{Ker } d\mu$ and tangent to T ; hence $v = 0$, proving transversality. Finally, that the transversal is simple follows from (14.16). This concludes the proof of the lemma. \square

Since $\tilde{\Omega}$ is closed and of constant rank and since we have shown that $\Pi(M, \pi)$ is the leaf space of the induced characteristic foliation, we obtain the symplectic form Ω on $\Pi(M, \pi)$. Since $\Pi(S, \mathcal{F}) \rightarrow \Pi(M, \mathcal{F})$ is a submersion and a morphism of groupoids, the multiplicativity of $\tilde{\Omega}$ implies the one of Ω .

Hence $(\Pi(M, \pi), \Omega)$ becomes a symplectic groupoid. Using the isomorphism $\tau : \Pi(M, \pi) \times S \xrightarrow{\sim} \Pi(S, \mathcal{F})$ from (14.16), as groupoids over S , the definition of Ω can be rewritten as

$$\text{pr}_{\Pi(M, \pi)}^* \Omega = \tau^*(\mathbf{t}_{\mathcal{F}}^* \omega - \mathbf{s}_{\mathcal{F}}^* \omega) = \mathcal{A}^* \omega - \text{pr}_S^* \omega.$$

Hence, we obtain a symplectic groupoid action. From Proposition 14.42 it follows that μ is a Poisson map when M is endowed with the Poisson structure π_1 induced from the symplectic groupoid. Since μ is a surjective submersion, we must have $\pi_1 = \pi$. This proves (iii) \Rightarrow (ii) and the rest of the statement of Theorem 14.50. \square

We state now some direct consequences of the proof above.

Corollary 14.54. *Let $\mu : (S, \omega) \rightarrow (M, \pi)$ be a complete symplectic realization with connected fibers. Then the symplectic groupoid $(\Pi(M, \pi), \Omega) \rightrightarrows M$ has the following properties:*

- (i) *The action of $(\Pi(M, \pi), \Omega) \rightrightarrows M$ on $\mu : (S, \omega) \rightarrow M$ by parallel transport is a smooth symplectic groupoid action.*
- (ii) *The \mathbf{t} -fibers of $\Pi(M, \pi)$ are diffeomorphic to the universal covers of the orbits of the infinitesimal action.*

Proof. The action of $\Pi(M, \pi) \rightrightarrows M$ on $\mu : S \rightarrow M$ by parallel transport coincides with the composition of the diffeomorphism (14.16) with the target map of $\Pi(S, \mathcal{F})$. Hence it is smooth. Also, by construction, the source fibers of $\Pi(S, \mathcal{F}) \simeq \Pi(M, \pi) \times S$ are isomorphic to the universal covers of the leaves of \mathcal{F} . On the other hand, the source fiber of $\Pi(M, \pi) \times S$ over p coincides with the source fiber of $\Pi(M, \pi)$ over $\mu(p)$. \square

Corollary 14.55. *For any Poisson manifold (M, π) , the following are equivalent:*

- (i) *$\Pi(M, \pi) \rightrightarrows M$ is a Hausdorff Lie groupoid.*
- (ii) *(M, π) admits a complete Hausdorff symplectic realization with connected fibers and 1-connected orbits.*
- (iii) *(M, π) admits a complete symplectic realization with connected fibers and such that the homotopy groupoid of the orbit foliation is Hausdorff.*

Proof. For (i) \Rightarrow (ii), we use the Poisson homotopy groupoid as the symplectic realization.

For (ii) \Rightarrow (iii), note that by assumption the homotopy groupoid can be injectively immersed into the pair groupoid: $(\mathbf{t}_{\mathcal{F}}, \mathbf{s}_{\mathcal{F}}) : \Pi(S, \mathcal{F}) \rightarrow S \times S$. Hence it must be Hausdorff.

The implication (iii) \Rightarrow (i) follows because the fiber product $\Pi(M, \pi) \times S$ is Hausdorff and S is Hausdorff. This is a general fact: if $\mu : S \rightarrow M$ is a submersion between Hausdorff manifolds and $f : X \rightarrow M$ is a smooth map from a possibly non-Hausdorff space such that $X \times_M S$ is Hausdorff, then X is Hausdorff. \square

In the proof of the corollary above one can replace the homotopy groupoid of the orbit foliation by other integrations, provided they satisfy an additional assumption:

Corollary 14.56. *Let $\mu : (S, \omega) \rightarrow (M, \pi)$ be a complete symplectic realization with connected fibers. Let $\mathcal{G} \rightrightarrows S$ be a Hausdorff \mathfrak{t} -connected groupoid integrating the orbit foliation \mathcal{F} . Then there exists a Hausdorff symplectic groupoid*

$$(\Pi^{\mathcal{G}}(M, \pi), \Omega^{\mathcal{G}}) \rightrightarrows (M, \pi),$$

together with a symplectic groupoid action on $\mu : (S, \omega) \rightarrow M$, such that the resulting action groupoid is isomorphic to \mathcal{G} :

$$\Pi^{\mathcal{G}}(M, \pi) \times S \simeq \mathcal{G}.$$

Proof. We use notation similar to the proof of Theorem 14.50:

$$\Pi^{\mathcal{G}}(M, \pi) := \mathcal{G} / \text{Ker } \tilde{\Omega}^{\mathcal{G}}, \quad \tilde{\Omega}^{\mathcal{G}} := \mathfrak{t}_{\mathcal{G}}^* \omega - \mathfrak{s}_{\mathcal{G}}^* \omega.$$

The facts that $\tilde{\Omega}^{\mathcal{G}}$ is closed and of the same rank as before follow in exactly the same way. Hence $\Pi^{\mathcal{G}}(M, \pi)$ is defined as a set. We will see that we have the following commutative diagram:

$$\begin{array}{ccccc}
 & & \tau^{\mathcal{G}} & & \\
 & & \curvearrowright & & \\
 \Pi(M, \pi) \times S & \xrightarrow{\tau} & \Pi(S, \mathcal{F}) & \xrightarrow{\text{pr}} & \mathcal{G} \\
 & \searrow & \downarrow \Phi & & \downarrow \Phi^{\mathcal{G}} \\
 & & \Pi(M, \pi) & \xrightarrow{\text{pr}} & \Pi^{\mathcal{G}}(M, \pi) \simeq \mathcal{G} / \text{Ker } \tilde{\Omega}^{\mathcal{G}}
 \end{array}$$

We will apply the same steps as in the proof of Theorem 14.50 to show that the smooth structure descends.

By Lie’s Second Theorem and since the \mathfrak{t} -fibers of \mathcal{G} are connected, we have a canonical projection $\text{pr} : \Pi(S, \mathcal{F}) \rightarrow \mathcal{G}$. Similarly, we consider the replacements of the maps i_a for $[a] \in \Pi(M, \pi)$

$$(14.19) \quad i_a^{\mathcal{G}} = \text{pr} \circ i_a : \mu^{-1}(x) \rightarrow \mathcal{G}.$$

By precisely the same arguments as before, each $i_a^{\mathcal{G}}$ is an embedding. Furthermore, since pr is a local diffeomorphism, its differential at each point

sends the kernel of $\tilde{\Omega}$ from the previous proof isomorphically into the kernel of $\tilde{\Omega}^{\mathcal{G}}$. Denote

$$L_a := i_a(\mu^{-1}(x)).$$

The above shows that L_a is an open subset of a leaf L of $\text{Ker } \tilde{\Omega}_{\mathcal{G}}$. Next, note that $d_g \mathbf{s}_{\mathcal{G}}$ sends $\text{Ker } \tilde{\Omega}_{\mathcal{G}}|_g$ isomorphically to $\text{Ker } d_{\mathbf{s}(g)} \mu$, which follows by the similar property of $\tilde{\Omega}$. Therefore, the restriction of $\mathbf{s}_{\mathcal{G}}$ to L is a local diffeomorphism to $\mu^{-1}(x)$. So $i_a^{\mathcal{G}}$ is a section of the submersion $\mathbf{s}_{\mathcal{G}}|_L : L \rightarrow \mu^{-1}(x)$. Therefore, since L is Hausdorff, its image L_a must be closed in L . Hence, $L_a = L$. Finally, we show that $\mathbf{s}_{\mathcal{G}}^{-1}(T)$ is a simple transversal to the foliation, for any simple transversal T to $\text{Ker } \mu$. Transversality follows since $\mathbf{s}_F^{-1}(T)$ is a transversal for $\text{Ker } \tilde{\Omega}$ and pr relates the two transversals. To show that the transversal is simple, let $g_1, g_2 \in \mathbf{s}_F^{-1}(T) \cap L_a$. Then $\mathbf{s}_{\mathcal{G}}(g_1) = \mathbf{s}_{\mathcal{G}}(g_2) = p$, so we have $g_1 = i_a^{\mathcal{G}}(p) = g_2$. Therefore, $\Pi^{\mathcal{G}}$ is a smooth manifold and $\tilde{\Omega}^{\mathcal{G}}$ descends to a symplectic form $\Omega^{\mathcal{G}}$ on $\Pi^{\mathcal{G}}(M, \pi)$.

Notice that the source and target maps descend to maps $\Pi^{\mathcal{G}}(M, \pi) \rightrightarrows M$, so that we can still talk about “composable” elements. Note that $\Pi^{\mathcal{G}}(M, \pi)$ is a quotient of $\Pi(M, \pi)$ modulo the equivalence relation

$$g_1 \cong g_2 \iff L_{a_1} = L_{a_2} \iff \begin{cases} \mathbf{s}_{\mathcal{G}}(g_1) = \mathbf{s}_{\mathcal{G}}(g_2) =: x, & \mathbf{t}_{\mathcal{G}}(g_1) = \mathbf{t}_{\mathcal{G}}(g_2), \\ \tau^{\mathcal{G}}(g_1, p) = \tau^{\mathcal{G}}(g_2, p), & \forall p \in \mu^{-1}(x) \end{cases}$$

where $g_i = [a_i]$. Note that since the leaves form a partition, the last equality holds provided it holds for a single $p \in \mu^{-1}(x)$. We deduce that, for each $x \in M$, one obtains a subgroup of the Poisson homotopy group

$$\begin{aligned} \Gamma_x &:= \{k \in \Pi(M, \pi)_x : k \cong 1_x\} \\ &= \{k \in \Pi(M, \pi)_x : \tau^{\mathcal{G}}(k, p) = 1_p \text{ for some } p \in \mu^{-1}(x)\} \\ &= \{k \in \Pi(M, \pi)_x : \tau^{\mathcal{G}}(k, p) = 1_p \forall p \in \mu^{-1}(x)\}. \end{aligned}$$

The fact that this a subgroup follows from the fact that $\tau^{\mathcal{G}}$ is a groupoid morphisms and, for the same reason, the groups Γ_x together form a normal subgroup of $\Pi(M, \pi)$: for $g : x \rightarrow y$ in $\Pi(M, \pi)$ one has

$$k \in \Gamma_x \iff gkg^{-1} \in \Gamma_y.$$

From this it follows immediately that the multiplication descends.

By construction, the symplectic groupoid action of $\Pi(M, \pi)$ descends to a symplectic groupoid action of $\Pi^{\mathcal{G}}(M, \pi)$, such that one obtains an isomorphism $\Pi^{\mathcal{G}}(M, \pi) \times S \simeq \mathcal{G}$. The same argument from the proof of the previous corollary shows that $\Pi^{\mathcal{G}}(M, \pi)$ is Hausdorff. \square

Remark 14.57 (Non-Hausdorff integrations). In the proof above, to construct the smooth structure on $\Pi^{\mathcal{G}}(M, \pi)$ we have only used that the leaves

of the foliation $\text{Ker } \tilde{\Omega}^{\mathcal{G}}$ are Hausdorff manifolds. Therefore, the result remains true for a non-Hausdorff complete symplectic realization under the assumption

$$\mathcal{G}|_{\mu^{-1}(L)} \text{ is Hausdorff for any symplectic leaf } L \text{ of } (M, \pi).$$

The resulting groupoid $\Pi^{\mathcal{G}}(M, \pi) \rightrightarrows M$ may be no longer Hausdorff.

This condition is in fact quite natural, and it holds in particular for the homotopy groupoid $\Pi(S, \mathcal{F}) \rightrightarrows S$. Moreover, assume that $\mu : (S, \omega) \rightarrow (M, \pi)$ is a complete symplectic realization with connected fibers, such that the action of $\Pi(M, \pi)$ descends to a symplectic groupoid action of a symplectic groupoid $(\Sigma, \Omega) \rightrightarrows (M, \pi)$. Then Σ arises as in the corollary using the action groupoid $\mathcal{G} = \Sigma \times S$, which does satisfy the condition above.

We can also see that the Poisson homotopy groupoid is the largest target connected symplectic integration of the Poisson manifold.

Proposition 14.58. *If $(\Sigma, \Omega_{\Sigma})$ is any symplectic integration of a Poisson manifold (M, π) , there is a morphism of symplectic groupoids*

$$\Phi : (\Pi(M, \pi), \Omega) \rightarrow (\Sigma, \Omega_{\Sigma}).$$

Moreover:

- (i) *If Σ is target connected, then Φ is surjective.*
- (ii) *If Σ is target 1-connected, then Φ is an isomorphism.*

Proof. Let $\Sigma^0 \rightrightarrows M$ be the \mathfrak{t} -connected component of the identity of Σ equipped with the restriction of Ω_{Σ} . This is still a symplectic groupoid integrating (M, π) and we can apply Corollary 14.56 to $\mathfrak{t} : \Sigma^0 \rightarrow M$ and the holonomy groupoid of the corresponding orbit foliation, i.e., the fibers of $\mathfrak{s} : \Sigma^0 \rightarrow M$. The corollary then gives a symplectic groupoid — easily seen to be canonically isomorphic to $(\Sigma^0, \Omega_{\Sigma}) \rightrightarrows M$ — together with the desired morphism of symplectic groupoids

$$\Phi : (\Pi(M, \pi), \Omega) \rightarrow (\Sigma^0, \Omega_{\Sigma}) \subset (\Sigma, \Omega_{\Sigma}).$$

This morphism is onto Σ^0 so (i) follows. If $\Sigma = \Sigma^0$ and the \mathfrak{t} -fibers are 1-connected, it also follows that Φ is an isomorphism, so (ii) holds true. \square

Proof of Theorem 14.12. We are left with proving existence of the groupoid structure under the assumptions (i) and (ii).

We observe that $u(M)$ is transverse to the orbit foliation and of complementary dimension: since $\text{Ker } d\mu|_{u(M)}$ and $Tu(M)$ are complementary vector bundles, so are their symplectic orthogonals, i.e., $(\text{Ker } d\mu)^{\perp\omega}|_{u(M)}$ and $Tu(M)$. Since each orbit intersects $u(M)$ precisely once, it follows that we have a unique surjective submersion $\mu' : S \rightarrow M$ whose fibers are the

leaves of the symplectic orthogonal foliation and which has $u : M \rightarrow S$ as a section. The map μ' will be the source map of the groupoid structure on S .

We now apply Corollary 14.56 to the symplectic realization $\mu : (S, \omega) \rightarrow (M, \pi)$ whose orbit foliation is given by the submersion $\mu' : S \rightarrow M$. The holonomy groupoid of this foliation is the submersion groupoid

$$\mathcal{G} = S \times_{\mu'} S \rightrightarrows S.$$

Corollary 14.56 gives a symplectic groupoid $(\Sigma := \Pi^{\mathcal{G}}(M, \pi), \Omega) \rightrightarrows (M, \pi)$ together with a symplectic groupoid action \mathcal{A} on $\mu : S \rightarrow M$ whose orbits are the fibers of $\mu' : S \rightarrow M$. Moreover, the action gives an isomorphism of Lie groupoids

$$\Psi : \Sigma \times S \xrightarrow{\sim} S \times_{\mu'} S, \quad (g, p) \mapsto (\mathcal{A}(g, p), p).$$

Using the Lagrangian section $u : M \rightarrow S$ we obtain a map

$$\Phi : \Sigma \rightarrow S, \quad g \mapsto \mathcal{A}(g, u(\mathbf{s}(g))).$$

Notice that this map makes the following diagram commute:

$$\begin{array}{ccc} (\Sigma, \Omega) & \xrightarrow{\Phi} & (S, \omega) \\ \begin{array}{c} \downarrow \mathbf{t} \\ \downarrow \mathbf{s} \end{array} \Big) \mathbf{u} & & \begin{array}{c} \downarrow \mu \\ \downarrow \mu' \end{array} \Big) u \\ (M, \pi) & \xlongequal{\quad} & (M, \pi) \end{array}$$

Moreover, Φ is a diffeomorphism with inverse

$$\Phi^{-1}(p) = \text{pr}_{\Sigma} \circ \Psi^{-1}(p, u(\mu'(p))).$$

This allows us to transport the groupoid structure to S .

It remains to show that

$$\Phi^* \omega = \Omega.$$

To see this we use that \mathcal{A} is a *symplectic* groupoid action. We pull back the multiplicativity equation (14.14) via

$$i : \Sigma \times_M S, \quad g \mapsto (g, u(\mathbf{s}(g))).$$

Observing that $\mathcal{A} \circ i = \Phi$, $\text{pr}_1 \circ i = \text{Id}$, and $\text{pr}_2 \circ i = u \circ \mathbf{s}$, we obtain that

$$\Phi^* \omega = i^* \mathcal{A}^* \omega = i^* \text{pr}_1^* \Omega + i^* \text{pr}_2^* \omega = \Omega + \mathbf{s}^* u^* \omega = \Omega,$$

where we used that $u : M \rightarrow S$ is a Lagrangian section. □

Finally, we discuss symplectic groupoid actions of $(\Pi(M, \pi), \Omega)$. As in Section 14.4, to simplify the discussion, we only consider actions of $\Pi(M, \pi)$ on Hausdorff symplectic manifolds $\mu : (S, \omega) \rightarrow M$.

First, recall that, for any symplectic groupoid action, the moment map is a complete Poisson map — see Proposition 14.42. Conversely, consider a complete Poisson map $\mu : (S, \omega) \rightarrow (M, \pi)$, where (M, π) is an integrable

Poisson manifold. Just as for complete symplectic realizations, we have an action of $\Pi(M, \pi)$ on $\mu : S \rightarrow M$ by parallel transport — see Problem 12.5 for this more general case. It can be shown that this is a smooth action integrating the infinitesimal action of T^*M on $\mu : (S, \omega) \rightarrow (M, \pi)$. By Proposition 14.45, this is a symplectic groupoid action

$$\begin{array}{ccc}
 (\Pi(M, \pi), \Omega) \wr (S, \omega) & & \\
 \searrow & & \downarrow \mu \\
 & & (M, \pi)
 \end{array}$$

We obtain the following result, which generalizes the case studies of complete symplectic realizations from Chapter 12.

Theorem 14.59. *For any integrable Poisson manifold (M, π) and a Hausdorff symplectic manifold (S, ω) , we have a 1-to-1 correspondence*

$$\left\{ \begin{array}{l} \text{complete Poisson maps} \\ \mu : (S, \omega) \rightarrow (M, \pi) \end{array} \right\} \xleftrightarrow{\sim} \left\{ \begin{array}{l} (\Pi(M, \pi), \Omega)\text{-Hamiltonian} \\ \text{spaces } \mu : (S, \omega) \rightarrow M \end{array} \right\}.$$

14.7. Morita equivalence

Symplectic groupoid actions are closely related to the following notion:

Definition 14.60. A **Morita equivalence** between two Poisson manifolds (M_1, π_1) and (M_2, π_2) is a pair of complete symplectic realizations

$$\begin{array}{ccc}
 & (S, \omega) & \\
 \mu_1 \swarrow & & \searrow \mu_2 \\
 (M_1, \pi_1) & & (M_2, -\pi_2)
 \end{array}$$

whose fibers are symplectic orthogonal to each other and, moreover, all fibers are 1-connected.

Recall that by our convention, $\mu_1^{-1}(L_1)$ and $\mu_2^{-1}(L_2)$ are Hausdorff submanifolds, for all pairs of symplectic leaves $L_1 \subset M_1$ and $L_2 \subset M_2$. In fact, it follows that the resulting partitions of S into such submanifolds coincide, and this gives the leaf correspondence from Proposition 6.32.

By Theorem 14.50, any Poisson manifold that is part of a Morita equivalence has to be integrable. Also, Theorem 14.59 allows one to integrate

both legs of a Morita equivalence to symplectic groupoid actions

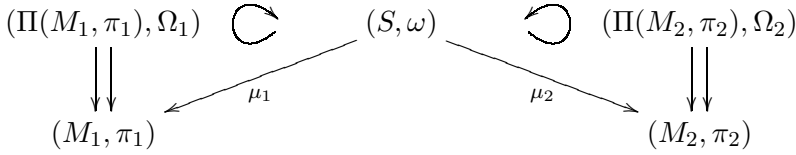

The right leg of the diagram is viewed as a right symplectic groupoid action. For this, we identify the Poisson homotopy groupoids

$$\Pi(M_2, \pi_2) \simeq \Pi(M_2, -\pi_2), \quad [a] \mapsto [-a].$$

Under this identification, the canonical symplectic form on $\Pi(M_2, -\pi_2)$ becomes $-\Omega_2$, where Ω_2 is the canonical symplectic form on $\Pi(M_2, \pi_2)$. So then we obtain a left symplectic groupoid action \mathcal{A}_2 of $(\Pi(M_2, \pi_2), -\Omega_2)$ on $\mu_2 : (S, \omega) \rightarrow (M_2, -\pi_2)$. Now we turn \mathcal{A}_2 into a right action, by setting

$$\overline{\mathcal{A}}_2(p, g) := \mathcal{A}_2(g^{-1}, p),$$

which becomes a right symplectic groupoid action of $(\Pi(M_2, \pi_2), \Omega_2)$ on $\mu_2 : (S, \omega) \rightarrow (M, \pi_2)$. As for any *right* symplectic groupoid action the moment map is anti-Poisson. We leave these remarks as an exercise.

This two actions enjoy the following properties:

- (i) $\mu_2 : S \rightarrow M_2$ is a principal (left) $\Pi(M_1, \pi_1)$ -bundle; i.e., the map

$$\Pi(M_1, \pi_1) \times_{M_1} S \rightarrow S \times_{M_2} S, \quad (g, p) \mapsto (g \cdot p, p)$$

is well-defined and is a diffeomorphism.

- (ii) Similarly, $\mu_1 : S \rightarrow M_1$ is a principal (right) $\Pi(M_2, \pi_2)$ -bundle.
- (iii) The two actions commute:

$$g \cdot (p \cdot h) = (g \cdot p) \cdot h,$$

whenever $\mathbf{s}_1(g) = \mu_1(p)$ and $\mu_2(p) = \mathbf{t}_2(h)$.

These are the axioms of a **symplectic Morita equivalence** between two symplectic groupoids $(\Sigma_i, \Omega_i) \rightrightarrows M_i, i = 1, 2$:

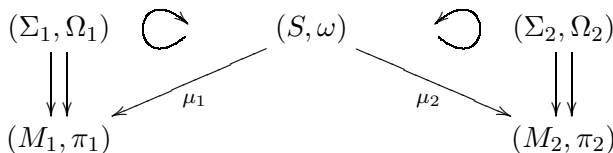

When restricting to integrable Poisson manifolds, Morita equivalence is indeed an *equivalence relation*. Symmetry is obvious, and reflexivity follows

by viewing the Poisson homotopy groupoid as a self-Morita equivalence

$$\begin{array}{ccc}
 & (\Pi(M, \pi), \Omega) & \\
 \swarrow \mathbf{t} & & \searrow \mathbf{s} \\
 (M, \pi) & & (M, -\pi)
 \end{array}$$

Transitivity can be obtained by a general procedure of composing symplectic Morita equivalences, applied to the Poisson homotopy groupoids. This procedure starts with a sequence of symplectic Morita equivalences

$$\begin{array}{ccccccc}
 (\Sigma_1, \Omega_1) \circlearrowleft & (S, \omega) & \circlearrowright (\Sigma_2, \Omega_2) \circlearrowleft & (S', \omega') & \circlearrowright (\Sigma_3, \Omega_3) \\
 \Downarrow \Downarrow & \swarrow \mu_1 & \searrow \mu_2 & \swarrow \mu'_2 & \searrow \mu_3 \\
 (M_1, \pi_1) & & (M_2, \pi_2) & & (M_3, \pi_3)
 \end{array}$$

and produces a symplectic Morita equivalence

$$\begin{array}{ccc}
 (\Sigma_1, \Omega_1) \circlearrowleft & (S \star S', \omega \star \omega') & \circlearrowright (\Sigma_3, \Omega_3) \\
 \Downarrow \Downarrow & \swarrow \bar{\mu}_1 & \searrow \bar{\mu}_3 \\
 (M_1, \pi_1) & & (M_3, \pi_3)
 \end{array}$$

where

$$S \star S' := (S \times_{M_2} S') / \Sigma_2$$

and $\omega \star \omega'$ descends from $\text{pr}_1^* \omega - \text{pr}_2^* \omega'$. Smoothness follows from properties (i) and (ii) above, and property (iii) ensures that the actions of Σ_1 and Σ_3 on $S \times_{M_2} S'$ also descend.

Example 14.61. Consider a free and proper Hamiltonian G -space (S, ω, μ) . Let $M := S/G$ endowed with the quotient Poisson structure π . Recall from Example 6.34 that we have the dual pair

$$\begin{array}{ccc}
 & (S, \omega) & \\
 \swarrow p & & \searrow \mu \\
 (M, \pi) & & (\mu(S), \pi_{\mathfrak{g}})
 \end{array}$$

This is a Morita equivalence precisely when the Lie group G and the fibers of μ are 1-connected.

Recall from Example 14.26 that (M, π) is integrable by the gauge groupoid $(S \times_{\mu} S) / G \rightrightarrows M$ with symplectic form Ω given in (14.4). Consider also the restriction $(T^*G|_{\mu(S)}, -\omega_{\text{can}}) \rightrightarrows (\mu(S), \pi_{\mathfrak{g}})$. Without the above assumptions, we still get a symplectic Morita equivalence between these

symplectic groupoids:

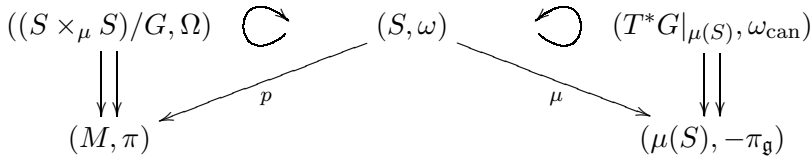

Note the change of sign in the right legs when passing from a dual pair to a symplectic Morita equivalence, as explained after Definition 14.60.

A Morita equivalence between two Poisson manifolds yields an identification of their transverse geometry, such as the following:

- homeomorphic leaf spaces and isomorphic algebras of Casimirs,
- isomorphic Poisson homotopy groups,
- isomorphic first Poisson cohomology groups, identifying their modular classes,
- equivalent categories of *Poisson vector bundles*, i.e., vector bundles endowed with a flat contravariant connection,
- equivalent categories of complete symplectic realizations,
- equivalent categories of $(\Pi(M, \pi), \Omega)$ -Hamiltonian spaces,
- isomorphic monodromy groups — see next section.

Some of these properties are contained in the problems at the end of the chapter, while others are harder to prove.

14.8. Integrability of Poisson structures II

So far we have ignored almost completely the issue of deciding when the cotangent Lie algebroid of a Poisson manifold integrates to a Lie groupoid. We now explain in detail the answer to this deep question, but we will not give complete proofs since they are beyond the scope of this book.

In the previous sections, we have seen that a Poisson manifold is integrable if and only if it admits a complete symplectic realization. However, this result does not solve the integrability problem: we saw before how difficult it may be to find complete symplectic realizations even for simple examples of Poisson structures. Also, there are simple examples of integrable Poisson manifolds which admit symplectic realizations that are not contained in any complete symplectic realization.

To obtain obstructions to integrability, we look closer at the Poisson homotopy groups.

Lemma 14.62. *If (M, π) is an integrable Poisson manifold, then $\Pi(M, \pi, x)$ is a Lie group with Lie algebra the isotropy Lie algebra $\text{Ker } \pi_x^{\#}$.*

Proof. When (M, π) is an integrable Poisson manifold, the Poisson homotopy groupoid is a Lie groupoid integrating T^*M . As for any Lie groupoid, its isotropy group at x is a Lie group with Lie algebra the kernel of the anchor at x , i.e., the isotropy Lie algebra $\text{Ker } \pi_x^\sharp$. \square

Let (M, π) be an integrable Poisson manifold, and denote by $\Pi(\mathfrak{g}_x)$ the 1-connected Lie group with Lie algebra $\mathfrak{g}_x = \text{Ker } \pi_x^\sharp$. There is a canonical homomorphism onto the identity component of $\Pi(M, \pi, x)$:

$$q_x : \Pi(\mathfrak{g}_x) \rightarrow \Pi(M, \pi, x)^0.$$

The kernel \mathcal{N}_x of this group homomorphism is a discrete subgroup of the center $Z(\Pi(\mathfrak{g}_x))$ and we have

$$(14.20) \quad \Pi(M, \pi, x)^0 \simeq \Pi(\mathfrak{g}_x) / \mathcal{N}_x.$$

Notice that \mathcal{N}_x coincides with the the fundamental group of $\Pi(M, \pi, x)$.

We can also see the groups \mathcal{N}_x appearing in a slightly different way. Let $S_x \subset M$ be the symplectic leaf containing x . Then the target map yields the principal $\Pi(M, \pi, x)$ -principal bundle:

$$\mathfrak{t} : \mathfrak{s}^{-1}(x) \rightarrow S_x.$$

Since $\mathfrak{s}^{-1}(x)$ is 1-connected, the long exact sequence in homotopy gives

$$\pi_2(S_x, x) \xrightarrow{\partial_x} \pi_1(\Pi(M, \pi, x)) \longrightarrow 1 \longrightarrow \pi_1(S_x, x) \longrightarrow \pi_0(\Pi(M, \pi, x)) \longrightarrow 1.$$

Using that $\mathcal{N}_x \simeq \pi_1(\Pi(M, \pi, x))$ and (14.20), we conclude that there is a short exact sequence of groups

$$\pi_2(S_x, x) \xrightarrow{\partial_x} \Pi(\mathfrak{g}_x) \xrightarrow{q_x} \Pi(M, \pi, x) \longrightarrow \pi_1(S_x, x) \longrightarrow 1$$

and that

$$\mathcal{N}_x = \text{Im } \partial_x.$$

So far we have assumed that (M, π) is integrable. Part of this discussion still makes sense also in the nonintegrable case, which allows us to define the groups \mathcal{N}_x in the general case.

Proposition 14.63. *For a general Poisson manifold (M, π) and any $x \in M$, there is a short exact sequence of groups*

$$\pi_2(S_x, x) \xrightarrow{\partial_x} \Pi(\mathfrak{g}_x) \xrightarrow{q_x} \Pi(M, \pi, x) \xrightarrow{p_x} \pi_1(S_x, x) \longrightarrow 1$$

where the following hold:

- (i) $p_x : \Pi(M, \pi, x) \rightarrow \pi_1(S_x, x)$ sends the class of a cotangent path to the homotopy class of its base path.
- (ii) $q_x : \Pi(\mathfrak{g}_x) \rightarrow \Pi(M, \pi, x)$ is induced by the inclusion $\mathfrak{g}_x \hookrightarrow T^*M$.

- (iii) $\partial_x : \pi_2(S_x, x) \rightarrow \Pi(\mathfrak{g}_x)$ sends the class of $\sigma : [0, 1] \times [0, 1] \rightarrow S_x$ to the class of a path $a : [0, 1] \rightarrow \mathfrak{g}_x$ which is cotangent path-homotopic to 0_x via a cotangent path-homotopy covering σ .

Proof. Recall from Chapter 13 that we have the identification

$$\Pi(\mathfrak{g}_x) = \frac{\mathfrak{g}_x\text{-paths}}{\mathfrak{g}_x\text{-homotopy}}.$$

Since the inclusion $\mathfrak{g}_x \hookrightarrow T^*M$ is a Lie algebroid map, each \mathfrak{g}_x -path is also a cotangent path and each \mathfrak{g}_x -path homotopy is also a cotangent path-homotopy. Hence, we have a well-defined map

$$q_x : \Pi(\mathfrak{g}_x) \rightarrow \Pi(M, \pi, x), \quad [a]_{\mathfrak{g}_x} \mapsto [a]_{T^*M}.$$

In order to show that the map $\partial_x : \pi_2(S_x, x) \rightarrow \Pi(\mathfrak{g}_x)$ is well-defined we need the following lemma. The proof is inspired by standard constructions from homotopy theory and will be omitted.

Lemma 14.64. *Denoting $I = [0, 1]$, we have:*

- (i) *Let $a : I \rightarrow T^*M$ be a cotangent path with base path $\gamma_a : I \rightarrow S_x$. Any path-homotopy $\sigma : I \times I \rightarrow S_x$ starting at γ_a can be lifted to a cotangent path-homotopy $\Phi : T(I \times I) \rightarrow T^*M$ starting at a .*
- (ii) *Two paths $a_0, a_1 : I \rightarrow \mathfrak{g}_x$ are \mathfrak{g}_x -path homotopic if and only if there is a cotangent path-homotopy $\Phi : T(I \times I) \rightarrow T^*M$ joining a_0 to a_1 whose base homotopy $\sigma : I \times I \rightarrow S_x$ is a trivial class: $0 = [\sigma] \in \pi_2(S_x, x)$.*

It is clear from the definitions that $\text{Im } \partial_x \subset \text{Ker } q_x$. To show the opposite inclusion, let $a : I \rightarrow \mathfrak{g}_x$ represent an element $[a]_{\mathfrak{g}_x} \in \text{Ker } q_x$. From the definition of q_x , this means that a is cotangent path-homotopic to 0_x . The corresponding cotangent path-homotopy $\Phi : T(I \times I) \rightarrow T^*M$ can be used in the definition of ∂_x to conclude that $\partial_x[\sigma] = [a]_{\mathfrak{g}_x}$, where σ is the base path of Φ .

It is clear from the definitions that $\text{Im } q_x \subset \text{Ker } p_x$. To show the opposite inclusion, let $[a_0] \in \Pi(M, \pi, x)$ have contractible base path $\gamma_0 : I \rightarrow S_x$. We can choose a path-homotopy $\sigma : I \times I \rightarrow S_x$ starting at γ_0 and ending at $\gamma_1(t) \equiv x$. By part (i) in the lemma, we can find a cotangent path-homotopy $\Phi : T(I \times I) \rightarrow T^*M$ starting at a_0 covering σ . The end cotangent path $a_1 : I \rightarrow T^*M$ of this homotopy is a \mathfrak{g}_x -path. Hence, $q_x([a_1]_{\mathfrak{g}_x}) = [a_0]_{T^*M}$.

Finally, surjectivity of p_x follows because any path in the leaf can be lifted to a cotangent path. □

Definition 14.65. Let (M, π) be a Poisson manifold. We call

$$\partial_x : \pi_2(S_x, x) \rightarrow \Pi(\mathfrak{g}_x)$$

the **monodromy map at x** and

$$\mathcal{N}_x := \text{Im } \partial_x$$

the **monodromy group at x** .

Corollary 14.66. Let (M, π) be a Poisson manifold. For each $x \in M$,

$$\Pi(M, \pi, x)^0 = \Pi(\mathfrak{g}_x)/\mathcal{N}_x.$$

In particular, if (M, π) is integrable, then the monodromy groups $\mathcal{N}_x \subset \Pi(\mathfrak{g}_x)$ must be discrete subgroups, for all $x \in M$.

Proof. With the quotient topologies from the Banach manifold of paths, the maps q_x and p_x in the exact sequence in the proposition are continuous. For these topologies $\Pi(\mathfrak{g}_x)$ is connected and $\pi_1(S_x, x)$ is discrete, so that

$$\Pi(M, \pi, x)^0 \subset \text{Ker } p_x = \text{Im } q_x \subset \Pi(M, \pi, x)^0. \quad \square$$

We will not discuss how to compute the monodromy groups at arbitrary points. However, for regular points — which form a dense open set — the monodromy map can be computed in terms of the variation of symplectic area of spheres, discussed in Section 10.6. At a regular point x , the isotropy Lie algebra is abelian, so $\Pi(\mathfrak{g}_x) = \nu_x^*(S_x)$ with group operation addition, and we have $\partial_x : \pi_2(S_x, x) \rightarrow \nu_x^*(S_x)$.

Proposition 14.67. For any regular point x of a Poisson manifold (M, π) the monodromy map ∂_x coincides with the variation of symplectic area map:

$$\partial_x = A'_x : \pi_2(S_x, x) \rightarrow \nu_x^*(S_x).$$

Hence, the monodromy group at a regular point x is given by

$$\mathcal{N}_x = \{A'_x(\sigma) \in \nu_x^*(S_x) : [\sigma] \in \pi_2(S_x, x)\}.$$

Exercise 14.68. Prove the proposition under the assumption that the foliation is a product around S_x , i.e., $S_x \times \mathbb{R}^q$.

HINT: If $\alpha = A'_x(\sigma)$, build a cotangent path-homotopic between the constant cotangent paths α and 0_x covering σ , using the proof of Theorem 10.44.

Example 14.69 (The first obstruction to integrability). We saw in Example 10.47 that the regular Poisson manifold $\mathbb{S}^2 \times \mathbb{S}^2 \times \mathbb{R}_+$ with symplectic leaves

$$S_y = \mathbb{S}^2 \times \mathbb{S}^2 \times \{y\}, \quad \omega_y := y(\omega_1 + \lambda\omega_2),$$

where $\omega_i = \text{pr}_i^*(\frac{1}{4\pi}\omega_{\mathbb{S}^2})$, has monodromy groups

$$\mathcal{N}_x = \text{Im } A'_x = \mathbb{Z} + \lambda\mathbb{Z} \subset \mathbb{R}.$$

Therefore this Poisson manifold is nonintegrable whenever $\lambda \notin \mathbb{Q}$. 

Although the discreteness of every monodromy group is a necessary condition for integrability, it is not a sufficient condition.

Consider, for example, a regular Poisson manifold (M, π) . If (M, π) is integrable so that $\Pi(M, \pi) \rightrightarrows M$ is a Lie groupoid, then the connected components of the isotropy groups form a smooth bundle of groups, which by Corollary 14.66 takes the form

$$\bigcup_{x \in M} \Pi(M, \pi, x)^0 = \nu^*(\mathcal{F}_\pi) / \bigcup_{x \in M} \mathcal{N}_x.$$

For this bundle to be smooth we need more than the discreteness of each group \mathcal{N}_x , we need these groups to be *uniformly discrete*. By this we mean that there exists a neighborhood $U \subset \nu^*(\mathcal{F}_\pi)$ of the zero section such that

$$U \cap \mathcal{N}_x = \{0_x\}, \quad \forall x \in M.$$

Exercise 14.70. Let $E \rightarrow M$ be a vector bundle, and let $\Lambda \subset E$ be a family of discrete subgroups. Show that if E/Λ has a smooth structure such that the projection $E \rightarrow E/\Lambda$ is a submersion, then there exists an open set $U \subset E$ such that $U \cap \Lambda_x = \{0_x\}$, for all $x \in M$.

The next example shows that this can indeed occur.

Example 14.71 (The second obstruction to integrability). Consider the regular Poisson manifold $\mathbb{S}^2 \times \mathbb{R}$ with symplectic leaves

$$S_y = \mathbb{S}^2 \times \{y\}, \quad \omega_y := (1 + y^2) \frac{1}{4\pi} \omega_{\mathbb{S}^2}.$$

As in Example 10.47, one can compute the variation of symplectic area and obtain the monodromy groups

$$\mathcal{N}_{(p,y)} = 2y\mathbb{Z}.$$

The groups are all discrete, but not in a uniform manner. Historically, this was the first example of a nonintegrable Poisson manifold — see [151]. 

When (M, π) is not necessarily regular, we can proceed as follows. For each $x \in M$ we consider the exponential map

$$\exp : \mathfrak{g}_x \rightarrow \Pi(\mathfrak{g}_x),$$

so that $\exp^{-1}(\mathcal{N}_x) \subset \mathfrak{g}_x \subset T_x^*M$. Then we define:

Definition 14.72. Let (M, π) be a Poisson manifold. We say that its monodromy groups are **uniformly discrete** if there is a neighborhood $U \subset T^*M$ of the zero section such that

$$U \cap \exp^{-1}(\mathcal{N}_x) = \{0_x\}, \quad \forall x \in M.$$

The general integrability criterion is the following:

Theorem 14.73 (Crainic and Fernandes). *A Poisson manifold (M, π) is integrable if and only if the monodromy groups are uniformly discrete.*

The proof of this theorem is beyond the scope of this book. We refer the reader to [41] and [45].

Example 14.74 (Severely non-Hausdorff integration). We build an example of an integrable Poisson manifold (M, π) whose Poisson homotopy groupoid does not admit a Riemannian metric. This implies also that no other groupoid integrating T^*M can be Hausdorff.

Consider the regular Poisson structure π on $\hat{M} = \mathbb{S}^2 \times \mathbb{S}^2 \times (-1, 1)$ with symplectic leaves

$$S_y := \mathbb{S}^2 \times \mathbb{S}^2 \times \{y\}, \quad \omega_y := (1 + y)\omega_1 + \frac{(1 + y)^2}{2}\omega_2,$$

where $\omega_i = \text{pr}_i^*(\frac{1}{4\pi}\omega_{\mathbb{S}^2})$.

Then (\hat{M}, π) is not integrable. This follows by computing its monodromy groups as the variation of symplectic area, and then we obtain

$$\hat{\mathcal{N}}_{(p_1, p_2, y)} = \mathbb{Z} + (1 + y)\mathbb{Z}.$$

However, π is integrable when restricted to the following open subset:

$$M := \hat{M} \setminus C, \quad C := (\mathbb{S}^2 \times \{p_N\} \times (-1, 0]) \cup (\{p_N\} \times \mathbb{S}^2 \times [0, 1)).$$

In other words, for $y \leq 0$ we removed the north pole p_N from the second sphere, and for $y \geq 0$ we removed p_N from the first sphere. The monodromy groups of (M, π) are given by

$$\mathcal{N}_{(p_1, p_2, y)} = \begin{cases} \mathbb{Z}, & y < 0, \\ 0, & y = 0, \\ (1 + y)\mathbb{Z}, & y > 0. \end{cases}$$

Since every element in \mathcal{N} which is not on the zero section is at distance at least 1 from the zero section, it follows that (M, π) is an integrable Poisson manifold. However, since \mathcal{N} is not closed, the Poisson homotopy groupoid is not Hausdorff.

We claim that $\Pi(M, \pi) \rightrightarrows M$ does not admit a Riemannian metric. If it does, then so does its pullback along the map

$$i : (-1, 1) \rightarrow M, \quad i(y) = (p_S, p_S, y),$$

which we denote

$$\mathcal{G} := i^* \Pi(M, \pi) \rightrightarrows (-1, 1).$$

Note that $i(-1, 1)$ is a Poisson transversal, which hits every leaf exactly once. Since the leaves of (M, π) are 1-connected, \mathcal{G} is the bundle of groups

$$\mathcal{G} = ((-1, 1) \times \mathbb{R}) / \Lambda, \quad \Lambda_y = \begin{cases} \mathbb{Z}, & y < 0, \\ 0, & y = 0, \\ (1 + y)\mathbb{Z}, & y > 0. \end{cases}$$

By Example 13.93, \mathcal{G} does not admit any Riemannian metric. It is remarkable that this example appeared already in [1]. 

Problems

14.1. Show that on the pair groupoid $M \times M \rightrightarrows M$, any multiplicative form ω is of the form $\omega = \text{pr}_1^* \eta - \text{pr}_2^* \eta$, for a form η on M .

14.2. Let ω be a differential form on a vector bundle $E \rightarrow M$, viewed as a Lie groupoid $E \rightrightarrows M$. Show that ω is multiplicative if and only if it is linear, in the sense that

$$m_t^* \omega = t \omega, \quad \forall t > 0.$$

14.3. Show that if $\omega \in \Omega^2(\mathcal{G})$ is a multiplicative 2-form on a Lie groupoid $\mathcal{G} \rightrightarrows M$ with Lie algebroid A , then

$$\mathcal{L}_{\vec{\alpha}}(i_{\vec{\beta}} \omega) = 0, \quad \forall \alpha, \beta \in \Gamma(A).$$

14.4. Let $(\Sigma \rightrightarrows M, \Omega)$ be a symplectic groupoid and denote by $\pi \in \mathfrak{X}^2(M)$ the Poisson structure induced on the base. A bisection $b : M \rightarrow \Sigma$ — see Problem 13.13 — is called Lagrangian if $b^* \Omega = 0$. Show the following:

(a) Right translation by a Lagrangian bisection b

$$R_b : \Sigma \rightarrow \Sigma, \quad g \mapsto g \cdot b(\mathbf{s}(g))$$

is a symplectomorphism.

(b) For a Lagrangian bisection b , the map $\mathbf{s} \circ b : M \rightarrow M$ is a Poisson diffeomorphism.

(c) Lagrangian bisections form a subgroup $\Gamma(\Sigma, \Omega)$ of $\Gamma(\Sigma)$.

(d) Determine the group $\Gamma(\Sigma, \Omega)$ for the symplectic pair groupoid of Example 14.5 and for the cotangent groupoid of Example 14.6.

14.5. Let $(\Sigma, \Omega) \rightrightarrows M$ be a symplectic groupoid. Show that for any complete section $\alpha \in \Gamma(A)$, one has

$$\exp(\alpha)^*\Omega = \int_0^1 (\phi_{\rho(\alpha)}^t)^*(d\sigma_\Omega(\alpha)) dt,$$

where the exponential map was defined in Problem 13.14. Conclude that $\exp(\alpha)$ is a Lagrangian bisection whenever $\sigma_\Omega(\alpha)$ is closed.

14.6. Let $\Sigma := (\mathbb{S}^1 \times \mathbb{R}) \setminus \{(-1, 0)\}$. Consider the symplectic realization

$$\mu = \text{pr}_2 : \Sigma \rightarrow \mathbb{R}, \quad \Omega = \frac{1}{x^2(1 - \sin(\theta)) + \cos(\theta) + 1} d\theta \wedge dx.$$

Show the following:

- (a) μ is a complete symplectic realization.
- (b) $(\Sigma, \Omega) \rightrightarrows \mathbb{R}$ is a symplectic groupoid with unit section u source and target $\mathbf{s} = \mathbf{t} = \mu$, and find the groupoid multiplication explicitly.

HINT: Use the description of the multiplication in terms of the flow of left/right-invariant vector fields, as in the proof of Theorem 14.12.

14.7. Let $(\Sigma \rightrightarrows M, \Omega)$ be a symplectic groupoid, and let $\pi \in \mathfrak{X}^2(M)$ be the induced Poisson structure on the base. Consider

$$\Omega_B := \Omega + \mathbf{t}^*B - \mathbf{s}^*B,$$

where $B \in \Omega^2(M)$ is a closed 2-form. Show the following:

- (a) Ω_B is closed and multiplicative.
- (b) Ω_B is symplectic if and only if for every symplectic leaf (S, ω_S) of (M, π) the form $\omega_S + B|_S$ is nondegenerate.
- (c) $(\Sigma \rightrightarrows M, \Omega_B)$ is a symplectic integration of the gauge transformed Poisson structure $e^B\pi$, whenever defined — compare with Example 7.52.

HINT: For (b) see the proof of Proposition 14.30.

14.8. Consider a Poisson manifold (M, π) of the form $M = S \times (-1, 1)$ and with symplectic leaves

$$S_y := S \times \{y\}, \quad \omega_y := \omega_0 + y\eta \quad (y \in (-1, 1)).$$

Assume that η is the curvature 2-form of a principal \mathbb{S}^1 -bundle $P \rightarrow S$. Build a symplectic groupoid integrating (M, π) .

HINT: See Section 4.4.

14.9. Let $\mathcal{A} : \Sigma \times_M S \rightarrow S$ be a left symplectic groupoid action of $(\Sigma, \Omega) \rightrightarrows M$ on $\mu : (S, \omega) \rightarrow M$. Show that

$$\overline{\mathcal{A}} : S \times_M \Sigma \rightarrow S, \quad \overline{\mathcal{A}}(p, g) := \mathcal{A}(g^{-1}, p)$$

is a right symplectic groupoid action of $(\Sigma, -\Omega) \rightrightarrows M$ on $\mu : (S, \omega) \rightarrow M$. Conclude that the moment map of a right symplectic groupoid action is anti-Poisson.

14.10. For a (possibly disconnected) Lie group G , show that symplectic groupoid actions of $(G \ltimes \mathfrak{g}^*, \Omega) \rightrightarrows \mathfrak{g}^*$ are the same as G -Hamiltonian spaces (S, ω, μ) .

14.11. Let $p : (M, \omega) \rightarrow \mathbb{S}^1$ be a symplectic fibration, i.e., a surjective submersion endowed with a closed 2-form $\omega \in \Omega^2(M)$ such that the restriction to each fiber of p is symplectic. Consider the symplectic manifold

$$S := M \times \mathbb{S}^1, \quad \omega_S := \text{pr}_1^* \omega + \mu^*(d\theta) \wedge d\varphi,$$

where $\mu = p \circ \text{pr}_1 : S \rightarrow \mathbb{S}^1$.

(a) Show that the action of \mathbb{S}^1 on the second factor of S is Hamiltonian with \mathbb{S}^1 -valued moment map μ (in the sense of Example 14.43):

$$i_{-\frac{\partial}{\partial \varphi}} \omega_S = \mu^*(d\theta).$$

(b) Find the symplectic quotients $S //_c \Sigma := \mu^{-1}(c) / \mathbb{S}^1$, where Σ is the symplectic groupoid $(\mathbb{S}^1 \times \mathbb{S}^1, d\theta \wedge d\varphi) \rightrightarrows \mathbb{S}^1$.

(c) Construct a symplectic groupoid integrating the quotient Poisson manifold $M = S / \mathbb{S}^1$, by adapting the methods from Example 14.26 to the case of an \mathbb{S}^1 -valued moment map.

14.12. Let $(\Sigma, \Omega) \rightrightarrows (M, \pi)$ be a symplectic groupoid. Let G be a Lie group acting by groupoid automorphisms on (Σ, Ω) . Assume that the action is Hamiltonian with moment map

$$\mu : \Sigma \rightarrow \mathfrak{g}^*.$$

(a) Show that $d\mu \in \Omega^1(\Sigma, \mathfrak{g}^*)$ is multiplicative.

(b) If Σ has connected \mathfrak{t} -fibers, show that one can choose a new moment map that is a groupoid map

$$\mu(g \cdot h) = \mu(g) + \mu(h).$$

(c) The induced action of G on the base (M, π) is a Poisson action.

(d) The action of G on the base M is proper and free if and only if the action on Σ is proper and free.

- (e) Assume that the action of G is proper and free and that the moment map is a groupoid map. Show that the symplectic quotient $\Sigma //_0 G$ is a symplectic groupoid over M/G integrating the quotient Poisson structure.

14.13. Consider a Morita equivalence between two Poisson manifolds

$$\begin{array}{ccc}
 & (S, \omega) & \\
 \mu_1 \swarrow & & \searrow \mu_2 \\
 (M_1, \pi_1) & & (M_2, -\pi_2)
 \end{array}$$

Show the following:

- (a) We have a homeomorphism between the leaf spaces, such that S_1 corresponds to S_2 iff $\mu_1^{-1}(S_1) = \mu_2^{-1}(S_2)$.
- (b) The algebras of Casimirs of (M_1, π_1) and (M_2, π_2) are isomorphic.
- (c) If x_1 and x_2 belong to leaves that correspond to each other, then the Poisson homotopy groups are isomorphic: $\Pi(M_1, \pi_1, x_1) \simeq \Pi(M_2, \pi_2, x_2)$.
- (d) If x_1 and x_2 belong to leaves that correspond to each other, then the monodromy groups are isomorphic: $\mathcal{N}_{x_1} \simeq \mathcal{N}_{x_2}$.

14.14. Show that two connected symplectic manifolds are Morita equivalent if and only if they have isomorphic fundamental groups.

14.15. Let $(\Sigma, \Omega) \rightrightarrows M$ be a symplectic groupoid with induced Poisson structure π . Let (X, π_X) be a Poisson transversal in (M, π) . Show the following:

- (a) $\Sigma_X := (\mathbf{t}, \mathbf{s})^{-1}(X \times X) \rightrightarrows X$ is a smooth symplectic subgroupoid of Σ which induces π_X on the base.
- (b) If X intersects each symplectic leaf of M , then the symplectic groupoids $(\Sigma, \Omega) \rightrightarrows M$ and $(\Sigma_X, \Omega|_{\Sigma_X}) \rightrightarrows X$ are symplectic Morita equivalent groupoids.

HINT: Use Proposition 5.26.

14.16. On $(\mathbb{R}^4, \omega_{\text{can}} = dx \wedge dy + dq \wedge dp)$ consider the following symplectic action of $(\mathbb{Z}, +)$:

$$n \cdot (x, y, q, p) = (x + n, y, \Phi^n(q, p)),$$

where Φ is a symplectomorphism of $(\mathbb{R}^2, dq \wedge dp)$ such that $\text{supp}(\Phi - \text{Id}) = \mathbb{R}^2 \setminus B$, where B is an open ball. Show the following:

- (a) The following is a complete Hausdorff symplectic realization:

$$\begin{aligned}
 \mu : (S, \omega) &:= (\mathbb{R}^4, \omega_{\text{can}}) / \mathbb{Z} \rightarrow \left(\mathbb{S}^1 \times \mathbb{R}, -\frac{\partial}{\partial \varphi} \wedge \frac{\partial}{\partial y} \right), \\
 \mu(x, y, q, p) &= (e^{2\pi xi}, y).
 \end{aligned}$$

- (b) If \mathcal{F} denotes the orbit foliation, show that $\text{Hol}(S, \mathcal{F}) \rightrightarrows S$ is not a Hausdorff Lie groupoid.
- (c) Let \mathcal{K} be the foliation on $\text{Hol}(S, \mathcal{F}) \rightrightarrows S$ corresponding to the involutive distribution $\text{Ker}(\mathbf{t}^*\omega - \mathbf{s}^*\omega)$. Can $\text{Hol}(S, \mathcal{F})/\mathcal{K}$ be made into a smooth manifold such that the projection $\text{Hol}(S, \mathcal{F}) \rightarrow \text{Hol}(S, \mathcal{F})/\mathcal{K}$ is a surjective submersion?

HINT: See the proof of Corollary 14.56.

14.17. Let $\mathfrak{g} = \mathfrak{so}(3, \mathbb{R})$. Find $f \in C^\infty(\mathfrak{g}^*)$ for which $\pi = f \pi_{\mathfrak{g}}$ is a Poisson structure which is not integrable on any neighborhood of 0.

Notes and References for Part 4

The notion of complete symplectic realization was first proposed by Karasev [94, 95], who realized that the source/target maps of symplectic groupoids yield complete symplectic realizations. Karasev considers only symplectic realizations admitting a Lagrangian section, which he calls “phase spaces”; when such realizations are complete he calls them “global phase spaces”. Symplectic realizations were further studied by Coste, Dazord, and Weinstein [37], who showed that a local symplectic groupoid is a symplectic groupoid if and only if the source map is a complete symplectic realization. In these earlier works, in order to establish a connection between symplectic realizations and integrability, the realization was always required to admit a Lagrangian section. It was only after the introduction of cotangent paths and cotangent homotopy (more generally, A -paths and A -homotopy) in [41] that the equivalence between the existence of a complete symplectic realization and integrability was established in [42].

According to Bryant [18, Appendix], Lie algebroids have their origins in Élie Cartan’s work on Lie’s pseudogroups. Lie groupoids were introduced in geometry by Ehresmann [62], in his efforts to formulate a geometric theory of partial differential equations. In the late 1960s, Pradines had sketched in a series of short papers published in the *Comptes Rendus de l’Académie des Sciences de Paris* [132–134] a Lie theory for Lie algebroids and Lie groupoids. In particular, Pradines claimed that every Lie algebroid integrates to a global groupoid, but he did not give many details. With the aim of giving a complete proof of this statement, Mackenzie developed a strategy in the style of the Cartan and van Est [142] cohomological proof for the case

of Lie algebras and Lie groups. Mackenzie hoped and tried to show for some time that his cohomological obstruction vanished, during which he learned that Almeida and Molino [9] had found that the statement is actually false, while studying transversally parallelizable foliations. Still, Mackenzie's obstruction [113] allowed, in principle, to decide which *transitive* Lie algebroids were actually integrable. Meanwhile, various positive results were obtained for bundles of Lie algebras by Douady and Lazard [55], infinitesimal Lie algebra actions by Palais [129] and Dazord [52], some classes of Poisson manifolds by Weinstein [153], etc. It was Poisson geometry which had the strongest influence in the final solution to the integrability problem: the first insights into the failure of integrability in this context were obtained by Weinstein [151], Alcalde-Cuesta, Dazord, and Hector [1, 51, 88]. Later, the work of Cattaneo and Felder [32] on Poisson sigma models and the ideas of Ševera [145] on higher structures and homotopy, combined with the path space approach of Duistermaat and Kolk [61], led to a complete solution by Crainic and Fernandes [41]. Many references and historical notes about Lie algebroid and groupoid theory can be found in Mackenzie's second monograph [114]. The need for non-Hausdorff groupoids was observed already in the work of Douady and Lazard [55] on the integration of bundles of Lie algebras and it is well known in foliation theory.

Groupoids were introduced in Poisson geometry in the pioneering works of Karasev [94] and Weinstein [151]. Their main motivation was the quantization problem for Poisson manifolds [154]. The *quantization program*, still not completed to this day, aimed at quantizing symplectic groupoids as a means for relating Poisson manifolds to noncommutative algebras — a similar program was pursued independently by Zakrzewski [162]. A related but independent major development, which was very influential, was the proof by Kontsevich of the formality theorem [99], which implies that every Poisson manifold admits a deformation quantization.

After the work of Coste, Dazord, and Weinstein in [37] on local and global symplectic groupoids mentioned before, the next major step was the proof by Mackenzie and Xu [115] that a source 1-connected Lie groupoid integrating the cotangent algebroid of a Poisson manifold is a *symplectic* groupoid. Finally, the obstructions to integrability and their geometric interpretation as variation of symplectic area was achieved in [42]. These were the start of a long series of works on integrability problems for other geometric structures.

Symplectic groupoid actions and their Hamiltonian spaces were introduced by Mikami and Weinstein [120] and were further developed by Xu [158, 159]. Xu also defined and studied Morita equivalence in the setting of

Poisson geometry. The idea that Poisson geometry offers a general framework accommodating various moment theories also appeared in [33], without the explicit use of Lie groupoids. This philosophy was implemented later in various settings, such as in the theory of Poisson-Lie groups and their moment maps of Lu [110] and in the theory of Lie group-valued moment maps of Alekseev, Malkin, and Meinrenken [6].

Symplectic groupoids have now become one of the most important tools in the study of global questions in Poisson geometry. We hope that our introduction will arouse the reader's interest in learning more about this beautiful subject.

Part 5

Appendices

In the appendices to follow we collect some basic notions, notation, and results from Lie theory, symplectic geometry, and foliation theory which are used throughout the text.

Lie Groups

There are many excellent monographs presenting Lie theory from different points of view. Good references covering most of our needs are the books by Duistermaat and Kolk [61] — but note that their conventions for Lie algebras, Lie brackets, and actions differ from ours — and by Helgason [90] — who uses the same conventions as us.

A.1. Lie groups

Recall that a **Lie group** is a group G with a compatible smooth manifold structure, in the sense that the operations of multiplication $G \times G \rightarrow G$ and taking inverses $G \rightarrow G$ are smooth maps. The group operation gives rise to left/right translations

$$L_g : G \rightarrow G, \quad x \mapsto gx, \quad R_g : G \rightarrow G, \quad x \mapsto xg,$$

which allow us to move the geometry of G around the identity element $e \in G$ to any other point $g \in G$. On the other hand, the geometry around e is encoded by the Lie algebra structure on the tangent space $T_e G$. Recall that a **Lie algebra** is a vector space \mathfrak{g} endowed with **Lie bracket**, i.e., a map

$$[\cdot, \cdot]_{\mathfrak{g}} : \mathfrak{g} \times \mathfrak{g} \rightarrow \mathfrak{g}, \quad (u, v) \mapsto [u, v]_{\mathfrak{g}},$$

which is bilinear and skew-symmetric and satisfies the Jacobi identity

$$[u, [v, w]_{\mathfrak{g}}]_{\mathfrak{g}} + [v, [w, u]_{\mathfrak{g}}]_{\mathfrak{g}} + [w, [u, v]_{\mathfrak{g}}]_{\mathfrak{g}} = 0,$$

for all $u, v, w \in \mathfrak{g}$.

Given a basis $\{e^k\}$ of a Lie algebra $(\mathfrak{g}, [\cdot, \cdot]_{\mathfrak{g}})$ the Lie bracket is encoded by the corresponding **structure constants** c_k^{ij} , defined by the relations

$$[e^i, e^j]_{\mathfrak{g}} = \sum_k c_k^{ij} e^k.$$

The basic examples of Lie algebras are the vector space $\mathfrak{gl}(V) := \text{Lin}(V, V)$ of linear endomorphisms of a vector space V endowed with the commutator bracket $[A, B] = A \circ B - B \circ A$ and the set of vector fields $\mathfrak{X}(M)$ on a smooth manifold M endowed with the usual Lie bracket. Of course, the two examples are related via the interpretation of vector fields as derivations on the algebra of smooth functions on M and, in particular, as linear endomorphisms of $V = C^\infty(M)$.

Given a Lie group G , recall that its Lie algebra \mathfrak{g} is defined as follows:

- (i) As a vector space, \mathfrak{g} is the tangent space of G at the identity:

$$\mathfrak{g} := T_e G.$$

- (ii) \mathfrak{g} is identified with the space of vector fields on G that are invariant under all left translations:

$$\mathfrak{g} \xrightarrow{\sim} \mathfrak{X}_{\text{inv}}(G), \quad v \mapsto \overleftarrow{v}, \quad \text{with} \quad \overleftarrow{v}_g = dL_g(v).$$

- (iii) Using the last identification, one obtains the bracket operation $[\cdot, \cdot]_{\mathfrak{g}}$ on \mathfrak{g} from the standard Lie bracket of vector fields; more precisely,

$$[\cdot, \cdot]_{\mathfrak{g}} : \mathfrak{g} \times \mathfrak{g} \rightarrow \mathfrak{g}$$

is uniquely characterized by the property

$$(A.1) \quad \overleftarrow{[u, v]_{\mathfrak{g}}} = [\overleftarrow{u}, \overleftarrow{v}].$$

The vector fields of type $\overleftarrow{v} \in \mathfrak{X}_{\text{inv}}(G)$ are complete and their flows $\phi_{\overleftarrow{v}}^t$ commute with all left translations. The exponential map

$$\exp : \mathfrak{g} \rightarrow G, \quad \exp(v) := \phi_{\overleftarrow{v}}^1(e) \in G,$$

relates \mathfrak{g} back to G and can be used to express the flow as follows:

$$\phi_{\overleftarrow{v}}^t(g) = g \cdot \exp(tv).$$

Lie group homomorphisms $F : G \rightarrow H$ are group homomorphisms that are also smooth. **Lie algebra homomorphisms** $f : \mathfrak{g} \rightarrow \mathfrak{h}$ are linear maps that preserve the Lie brackets; i.e., $f([u, v]_{\mathfrak{g}}) = [f(u), f(v)]_{\mathfrak{h}}$. As one may expect, if F is a Lie group homomorphism, then its differential at the identity is a Lie algebra homomorphism.

Lie's Theorems clarify the precise relationship between Lie groups and finite-dimensional Lie algebras:

Lie I: If \mathfrak{g} is the Lie algebra of a Lie group G , then there exists a unique, up to isomorphism, 1-connected Lie group \tilde{G} with Lie algebra isomorphic to \mathfrak{g} .

Lie II: If G and H are two Lie groups with Lie algebras denoted \mathfrak{g} and \mathfrak{h} , respectively, and if G is 1-connected, then any Lie algebra morphism $f : \mathfrak{g} \rightarrow \mathfrak{h}$ comes from a unique morphism of Lie groups $F : G \rightarrow H$.

Lie III: Any Lie algebra comes from a Lie group; i.e., it is isomorphic to the Lie algebra of a Lie group.

All together, one finds that the world of Lie algebras is basically the same as the one of 1-connected Lie groups.

Analogously to left-invariant vector fields, on any Lie group G one can talk about **left-invariant differential forms**, which we denote by $\Omega_{\text{inv}}^\bullet(G)$. These are in a natural 1-to-1 correspondence with alternating forms on the Lie algebra \mathfrak{g} :

$$(A.2) \quad \bigwedge^k \mathfrak{g}^* \xrightarrow{\sim} \Omega_{\text{inv}}^k(G), \quad \omega \mapsto \overleftarrow{\omega}, \quad \text{with} \quad \overleftarrow{\omega}_g = (dL_{g^{-1}})^* \omega.$$

The inverse of this assignment is the evaluation at the identity element. The fact that left-invariant vector fields are closed under the Lie bracket is reflected in the fact that left-invariant differential forms form a subcomplex of the de Rham complex:

$$(\Omega_{\text{inv}}^\bullet(G), d) \subset (\Omega^\bullet(G), d).$$

Under the identification (A.2), the exterior derivative corresponds to a differential

$$d_{\mathfrak{g}} : \bigwedge^k \mathfrak{g}^* \rightarrow \bigwedge^{k+1} \mathfrak{g}^*.$$

This map can be written entirely using the Lie algebra structure:

$$d_{\mathfrak{g}} \omega(v_0, \dots, v_k) = \sum_{0 \leq i < j \leq k} (-1)^{i+j} \omega([v_i, v_j]_{\mathfrak{g}}, v_0, \dots, \widehat{v}_i, \dots, \widehat{v}_j, \dots, v_k).$$

This formula follows from the usual coordinate-free formula for the exterior derivative and (A.1). The complex $(\bigwedge^\bullet \mathfrak{g}^*, d_{\mathfrak{g}})$ is called the **Chevalley-Eilenberg complex** and its cohomology is called the **Lie algebra cohomology** of \mathfrak{g} :

$$H^k(\mathfrak{g}) := \frac{\text{Ker} \left(d_{\mathfrak{g}} : \bigwedge^k \mathfrak{g}^* \rightarrow \bigwedge^{k+1} \mathfrak{g}^* \right)}{\text{Im} \left(d_{\mathfrak{g}} : \bigwedge^{k-1} \mathfrak{g}^* \rightarrow \bigwedge^k \mathfrak{g}^* \right)}.$$

Consider a **representation** of \mathfrak{g} , i.e., a Lie algebra homomorphism

$$\rho : (\mathfrak{g}, [\cdot, \cdot]_{\mathfrak{g}}) \rightarrow (\mathfrak{gl}(V), [\cdot, \cdot]).$$

The **Lie algebra cohomology of \mathfrak{g} with coefficients** in (V, ρ) , denoted by $H^k(\mathfrak{g}, V)$, is the cohomology of the complex $(\bigwedge^{\bullet} \mathfrak{g}^* \otimes V, d_{\mathfrak{g}})$ where

$$\begin{aligned} d_{\mathfrak{g}}\omega(v_0, \dots, v_k) &= \sum_{i=0}^k (-1)^i \rho(v_i) \cdot \omega(v_0, \dots, \widehat{v}_i, \dots, v_k) \\ &+ \sum_{0 \leq i < j \leq k} (-1)^{i+j} \omega([v_i, v_j]_{\mathfrak{g}}, v_0, \dots, \widehat{v}_i, \dots, \widehat{v}_j, \dots, v_k). \end{aligned}$$

Recall the very useful vanishing result:

Theorem A.1 (Whitehead’s Lemma). *Let $(\mathfrak{g}, [\cdot, \cdot]_{\mathfrak{g}})$ be a semisimple Lie algebra. Then for every finite-dimensional representation (V, ρ) of \mathfrak{g} ,*

$$H^1(\mathfrak{g}, V) = 0 \quad \text{and} \quad H^2(\mathfrak{g}, V) = 0.$$

Finally, recall that the left **Maurer-Cartan form** of a Lie group G is the unique left-invariant 1-form on G with values in its Lie algebra \mathfrak{g} which at $g = e$ is the identity map. Explicitly, it is given by

$$(A.3) \quad \theta_G \in \Omega^1(G, \mathfrak{g}), \quad \theta_G(v) = dL_{g^{-1}}(v), \quad v \in T_g G.$$

In terms of a basis $\{e^k\}$ of \mathfrak{g} , the Maurer-Cartan form has components $\theta_k \in \Omega^1(G)$; i.e., $\theta_G = \sum_k \theta_k \otimes e^k$. These satisfy the Maurer-Cartan equations

$$(A.4) \quad d\theta_k + \frac{1}{2} \sum_{i,j} c_k^{ij} \theta_i \wedge \theta_j = 0.$$

These equations are often abbreviated to

$$d\theta_G + \frac{1}{2} [\theta_G, \theta_G] = 0.$$

Similarly, one can define the right Maurer-Cartan form.

A.2. Lie group actions

A **left action** of a Lie group G on a manifold M is a group homomorphism

$$\mathcal{A} : G \rightarrow \text{Diff}(M), \quad g \mapsto \mathcal{A}_g \quad (\mathcal{A}_g(x) = g \cdot x),$$

with the property that $(g, x) \mapsto g \cdot x$ is a smooth map from $G \times M$ to M .

Given an action of G on M , one can talk about the following:

- (i) The **isotropy group** of the action at $x \in M$:

$$G_x := \{g \in G : g \cdot x = x\}.$$

(ii) The **orbit** of the action through $x \in M$:

$$\mathcal{O}_x := G \cdot x = \{g \cdot x : g \in G\}.$$

Note that G_x is a closed subgroup. In general, one has that any closed subgroup H of a Lie group G is automatically an embedded submanifold and that the quotient G/H carries a smooth structure, uniquely determined by the condition that the quotient map is a submersion — see also Theorem A.9, below. Then the natural bijection between the collection of left cosets of G_x and the orbit through x ,

$$(A.5) \quad G/G_x \simeq \mathcal{O}_x, \quad g \cdot G_x \mapsto g \cdot x,$$

endows \mathcal{O}_x with a smooth structure. As such, it is an immersed submanifold of M .

Although the group $\text{Diff}(M)$ of diffeomorphisms of M is strictly speaking not a Lie group — at least not in the classical, finite-dimensional sense — it does behave like one, and the space $\mathfrak{X}(M)$ of vector fields on M behaves like its Lie algebra — think of flows of vector fields giving rise to diffeomorphisms. With this intuition in mind, the infinitesimal counterpart of a Lie group action is that of a **Lie algebra action** or **infinitesimal action** of a Lie algebra \mathfrak{g} on manifold M , defined as a Lie algebra morphism $\mathcal{a} : \mathfrak{g} \rightarrow \mathfrak{X}(M)$.

A smooth action \mathcal{A} of a Lie group G on M induces an infinitesimal action of its Lie algebra \mathfrak{g} :

$$(A.6) \quad \mathcal{a} : \mathfrak{g} \rightarrow \mathfrak{X}(M), \quad \mathcal{a}(v)_x := \left. \frac{d}{dt} \right|_{t=0} \exp(-tv) \cdot x.$$

Remark A.2. Note that \mathcal{a} is $-\text{d}_e \mathcal{A}$. The presence of the minus sign in (A.6) comes from the fact that the natural Lie bracket on $\mathfrak{X}(M)$ coming from the Lie group $\text{Diff}(M)$ is the anticommutator of derivations — as opposed to our convention.

In order to see that this is the case, embed $\text{Diff}(M) \subset \text{GL}(C^\infty(M))$ by taking pullbacks

$$\phi(f) := f \circ \phi^{-1}.$$

Note that “taking the inverse” is essential to making this embedding into a group homomorphism. Thinking of $T_{\text{id}} \text{Diff}(M) = \mathfrak{X}(M)$ and then taking the differential at the identity of the above embedding yields the embedding of the algebra of vector fields as derivations of $C^\infty(M)$:

$$\mathfrak{X}(M) \hookrightarrow \mathfrak{gl}(C^\infty(M)), \quad X \mapsto -\mathcal{L}_X.$$

So for this map to be a Lie algebra homomorphism, one should define the Lie bracket on $\mathfrak{X}(M)$ as the anticommutator of derivations.

Given an infinitesimal action $\mathcal{a} : \mathfrak{g} \rightarrow \mathfrak{X}(M)$ and assuming that \mathfrak{g} is the Lie algebra of a Lie group G , it is natural to wonder whether \mathcal{a} is induced

by an action of G on M . Lie's Second Theorem suggests that this is the case if G is 1-connected. However, note that if \mathfrak{a} is induced by an action of G on M , then all vector fields $\mathfrak{a}(v)$ are complete. So this is clearly an extra condition, which is related to the fact that $\text{Diff}(M)$ is not a finite-dimensional Lie group. With this in mind, one says that $\mathfrak{a} : \mathfrak{g} \rightarrow \mathfrak{X}(M)$ is a **complete infinitesimal action** if all vector fields $\mathfrak{a}(v)$, with $v \in \mathfrak{g}$, are complete. That this condition is also sufficient is a deep result, known as the Lie-Palais Theorem:

Proposition A.3 (Palais [129]). *Given a manifold M and a 1-connected Lie group G with Lie algebra \mathfrak{g} , (A.6) gives a 1-to-1 correspondence*

$$\left\{ \begin{array}{l} \text{complete actions} \\ \mathfrak{a} : \mathfrak{g} \rightarrow \mathfrak{X}(M) \end{array} \right\} \xleftrightarrow{\sim} \left\{ \begin{array}{l} \text{Lie group actions} \\ \mathcal{A} : G \rightarrow \text{Diff}(M) \end{array} \right\}.$$

In particular, if M is compact, any infinitesimal action of \mathfrak{g} comes from an action of G .

For a complete, elegant, proof see Theorem 20.16 in [106].

For a general infinitesimal action $\mathfrak{a} : \mathfrak{g} \rightarrow \mathfrak{X}(M)$ one can talk about the **isotropy Lie algebra** at $x \in M$

$$\mathfrak{g}_x := \text{Ker } \mathfrak{a}_x = \{v \in \mathfrak{g} : \mathfrak{a}(v)_x = 0\} \subset \mathfrak{g}.$$

If \mathfrak{a} comes from an action of G , then \mathfrak{g}_x is the Lie algebra of the isotropy group G_x . Similarly, but in a less obvious way, one can talk about the orbits of the infinitesimal action — see Proposition A.13 below.

Remark A.4 (Right actions). Of course, a completely similar discussion applies to right actions $M \times G \rightarrow M$, with one warning however: for the induced infinitesimal action to be a Lie algebra map, one does not need a minus sign when differentiating:

$$(A.7) \quad \mathfrak{a} : \mathfrak{g} \rightarrow \mathfrak{X}(M), \quad \mathfrak{a}(v)_x := \left. \frac{d}{dt} \right|_{t=0} x \cdot \exp(tv).$$

Of course, this is related to the fact that one can pass from right actions to left ones by defining $g \cdot x := x \cdot g^{-1}$.

Example A.5 (Adjoint action). One of the most fundamental examples of actions is the action of G on itself by conjugation,

$$C : G \rightarrow \text{Diff}(G), \quad (g, x) \mapsto gxg^{-1}.$$

Since $e \in G$ is a fixed point under conjugation, there is an induced action of G on its Lie algebra $\mathfrak{g} = T_e G$, called the **adjoint action**,

$$\text{Ad} : G \rightarrow \text{GL}(\mathfrak{g}) \subset \text{Diff}(\mathfrak{g}), \quad \text{Ad}_g(v) = \left. \frac{d}{dt} \right|_{t=0} g \exp(tv) g^{-1}.$$

Since Ad is a linear action, it is called the **adjoint representation** of G .

The associated infinitesimal action of the Lie algebra \mathfrak{g} on the vector space \mathfrak{g} ,

$$\text{ad} : \mathfrak{g} \rightarrow \mathfrak{X}(\mathfrak{g}), \quad (\text{ad}_v)_w := \left. \frac{d}{dt} \right|_{t=0} \text{Ad}_{\exp(-tv)} w,$$

is called the **adjoint action** of \mathfrak{g} , and it satisfies

$$(\text{ad}_v)_w = -[v, w],$$

where we use the identification $T_w \mathfrak{g} = \mathfrak{g}$.

Remark A.6. A **representation** of a Lie group $R : G \rightarrow \text{GL}(V)$ is the same thing as a linear action $\mathcal{A} : G \times V \rightarrow V$. At the infinitesimal level, one obtains the following:

- (i) The representation of the Lie algebra \mathfrak{g} on the vector space V :

$$\rho : \mathfrak{g} \rightarrow \mathfrak{gl}(V), \quad \rho(v) := \left. \frac{d}{dt} \right|_{t=0} R_{\exp(tv)}.$$

- (ii) The infinitesimal action of the Lie algebra \mathfrak{g} on the vector space V :

$$\mathfrak{a} : \mathfrak{g} \rightarrow \mathfrak{X}(V), \quad \mathfrak{a}(v)_w := \left. \frac{d}{dt} \right|_{t=0} \mathcal{A}(\exp(-tv), w).$$

To explain the relation between the two, recall that a **linear vector field** on a vector space V is a vector field which, as a derivation, maps linear functions to linear functions:

$$\mathfrak{X}^{\text{lin}}(V) := \{X \in \mathfrak{X}(V) : X(V^*) \subset V^*\}.$$

One can identify the Lie algebra $\mathfrak{gl}(V)$ with the Lie subalgebra $\mathfrak{X}^{\text{lin}}(V) \subset \mathfrak{X}(V)$, by setting

$$\mathfrak{gl}(V) \simeq \mathfrak{X}^{\text{lin}}(V), \quad T \longleftrightarrow X_T, \text{ where } X_T(l) = -l \circ T, \forall l \in V^*.$$

The minus sign ensures that this is a Lie algebra isomorphism.

Under this identification, a representation $\rho : \mathfrak{g} \rightarrow \mathfrak{gl}(V)$ corresponds to an infinitesimal Lie algebra action by linear vector fields $\mathfrak{a} : \mathfrak{g} \rightarrow \mathfrak{X}^{\text{lin}}(V)$. In the special case of the adjoint action/representation we obtain the following:

- (i) The adjoint representation of \mathfrak{g} on the vector space \mathfrak{g} :

$$\text{ad} : \mathfrak{g} \rightarrow \mathfrak{gl}(\mathfrak{g}), \quad \text{ad}_v(w) = [v, w].$$

- (ii) The adjoint action of \mathfrak{g} on the manifold \mathfrak{g} :

$$\text{ad} : \mathfrak{g} \rightarrow \mathfrak{X}(\mathfrak{g}), \quad (\text{ad}_v)_w = -[v, w].$$

Although these formulas differ by a minus sign, we use the same symbol for both. Since we will be almost exclusively interested in actions this should not be a source of confusion. 

Example A.7 (Coadjoint action). If one dualizes Ad , then one obtains the so-called **coadjoint action** $\text{Ad}^* : G \times \mathfrak{g}^* \rightarrow \mathfrak{g}^*$, defined by

$$(\text{Ad}_g^* \xi)(v) = \xi(\text{Ad}_{g^{-1}}(v)),$$

where the presence of the inverse guarantees that this is a left action.

At the infinitesimal level, one obtains the Lie algebra action

$$\text{ad}^* : \mathfrak{g} \rightarrow \mathfrak{X}(\mathfrak{g}^*), \quad (\text{ad}_v^*)_\xi := \left. \frac{d}{dt} \right|_{t=0} \text{Ad}_{\exp(-tv)}^* \xi,$$

called the **infinitesimal coadjoint action** of \mathfrak{g} . Using the identification $T_\xi \mathfrak{g}^* = \mathfrak{g}^*$, it is given explicitly by

$$(A.8) \quad (\text{ad}_v^*)_\xi(w) = \xi([v, w]).$$

Note that, as above, we also have the **coadjoint representation** of the Lie algebra \mathfrak{g} on the vector space \mathfrak{g}^*

$$\text{ad}^* : \mathfrak{g} \rightarrow \mathfrak{gl}(\mathfrak{g}^*), \quad \text{ad}_v^* \xi(w) = -\xi([v, w]).$$

Of particular importance for us will be the orbits of the coadjoint action, the so-called **coadjoint orbits**. By the general theory, the coadjoint orbit through $\xi \in \mathfrak{g}^*$

$$\mathcal{O} := \{\text{Ad}_g^* \xi : g \in G\} \subset \mathfrak{g}^*$$

is an immersed submanifold of \mathfrak{g}^* and it carries a transitive action of G . At the infinitesimal level this means that at each $\xi \in \mathcal{O}$, the infinitesimal action

$$(A.9) \quad a_\xi : \mathfrak{g} \rightarrow T_\xi \mathcal{O} \subset \mathfrak{g}^*, \quad v \mapsto (\text{ad}_v^*)_\xi$$

is surjective. In particular, we have

$$T_\xi \mathcal{O} = \{(\text{ad}_v^*)_\xi : v \in \mathfrak{g}\} \subset \mathfrak{g}^*. \quad \curvearrowright$$

Exercise A.8. Let $\mathcal{A} : G \times M \rightarrow M$ be an action. Show that the induced infinitesimal action $a : \mathfrak{g} \rightarrow \mathfrak{X}(M)$ satisfies the following G -equivariance:

$$(A.10) \quad a(\text{Ad}_g v) = (\mathcal{A}_g)_* a(v).$$

Another basic, important result about a group action $G \times M \rightarrow M$ concerns the smooth structure on the orbit space

$$M/G := \{\mathcal{O}_x : x \in M\}.$$

For that, recall that an action $G \times M \rightarrow M$ is called as follows:

- (i) a **proper action** if the map $G \times M \rightarrow M \times M, (g, x) \mapsto (g \cdot x, x)$ is proper (in the sense that preimages of compacts are compacts),
- (ii) a **free action** if for all $x \in M$ we have that $g \cdot x = x \implies g = e$, i.e., if all isotropy groups G_x are trivial,
- (iii) a **locally free action** if for all $x \in M$ the isotropy groups G_x are discrete or, equivalently, if all isotropy Lie algebras \mathfrak{g}_x are trivial.

For a proper action all isotropy groups are compact. However, properness is more than just the compactness of the G_x and it may even happen that an action is free without being proper.

Theorem A.9. *For a free and proper action $G \times M \rightarrow M$, the quotient M/G admits a unique smooth structure such that the projection $M \rightarrow M/G$ is a submersion.*

Next, we discuss the relation between differential forms on M and on M/G . A form $\omega \in \Omega^*(M)$ is called **G -basic** if the following hold:

- (i) ω is **G -invariant**; i.e., $\mathcal{A}_g^*(\omega) = \omega$.
- (ii) ω is **horizontal**; i.e., $i_{\alpha(v)}\omega = 0$ for all $v \in \mathfrak{g}$.

We will denote by $\Omega_{G\text{-basic}}^*(M)$ the space of G -basic forms on M . It is a subalgebra of the exterior algebra $\Omega^*(M)$.

Proposition A.10. *Let G be a Lie group acting freely and properly on M , and let $p : M \rightarrow M/G$ be the quotient map. Then pullback by p induces an isomorphism of algebras*

$$p^* : \Omega^k(M/G) \xrightarrow{\simeq} \Omega_{G\text{-basic}}^k(M) \subset \Omega^k(M).$$

In degree 0 this proposition amounts to the identification between smooth functions on M/G and G -invariant functions on M via pullback

$$p^* : C^\infty(M/G) \xrightarrow{\simeq} C^\infty(M)^G \subset C^\infty(M).$$

A.3. Time-dependent vector fields

Recall that the flow ϕ_X^t of a vector field $X \in \mathfrak{X}(M)$ is defined by the ODE

$$\frac{d}{dt}\phi_X^t(x) = X(\phi_X^t(x)), \quad \phi_X^0(x) = x.$$

It satisfies the fundamental property

$$(A.11) \quad \phi_X^s \circ \phi_X^t = \phi_X^{s+t}.$$

One can think of $X \mapsto \phi_X^1$ as the exponential map from the Lie algebra $\mathfrak{X}(M)$ to the group $\text{Diff}(M)$, at least for complete vector fields. However, due to the infinite dimensionality of $\text{Diff}(M)$, these flows do not generate enough diffeomorphisms. Therefore, one often needs *time-dependent* vector fields. Since this topic is perhaps less familiar, here is a brief outline.

A **time-dependent vector field** is a smooth family of vector fields $X = \{X_t\}_{t \in I}$, where $I \subset \mathbb{R}$ is an interval, in the sense that we have a smooth map

$$X : M \times I \rightarrow TM, \quad (x, t) \mapsto X(x, t) := X_t(x) \in T_xM.$$

The **flow** $\Phi_X^{t,s}$ of a **time-dependent vector field** $X = \{X_t\}_{t \in I}$ satisfies:

- (i) It depends on the “time variable” t and the “starting time” s .
- (ii) It is defined on a neighborhood of $M \times \{(s, s) : s \in I\}$ in $M \times I \times I$.
- (iii) It consists of local diffeomorphisms $\Phi_X^{t,s} : M \rightarrow M$, determined by

$$\frac{d}{dt} \Phi_X^{t,s}(x) = X_t(\Phi_X^{t,s}(x)), \quad \Phi_X^{s,s}(x) = x.$$

The **integral curve** of $X = \{X_t\}_{t \in I}$ starting at time s and initial point x is the maximal solution of the equation

$$\frac{d\gamma}{dt}(t) = X_t(\gamma(t)), \quad \gamma(s) = x.$$

In other words, $\gamma(t) = \Phi_X^{t,s}(x)$.

Alternatively, one can promote $X = \{X_t\}_{t \in I}$ to the (single) time-independent vector field \tilde{X} on $M \times I$ given by

$$\tilde{X}(x, t) := X(x, t) + \frac{\partial}{\partial t}.$$

The integral curve of \tilde{X} starting at (x, s) is precisely $t \mapsto (\Phi_X^{t+s,s}(x), t + s)$. In other words, the flow of X is related to the flow of \tilde{X} by

$$\phi_{\tilde{X}}^t(x, s) = (\Phi_X^{t+s,s}(x), t + s).$$

The flow relations (A.11) for $\phi_{\tilde{X}}^t$ then yield

$$(A.12) \quad \Phi_X^{t,u} \circ \Phi_X^{u,s} = \Phi_X^{t,s}.$$

This shows that once we know the flow from a fixed $u \in I$ to any t close to u , then we know the flow $\Phi_X^{t,s}$ for all s, t around u . For simplicity, assume that $0 \in I$ and consider the family of local diffeomorphisms of M

$$\phi_X^\epsilon := \Phi_X^{\epsilon,0}.$$

Then the flow relations (A.12) imply that for parameters close to 0

$$\Phi_X^{t,s} = \phi_X^t \circ (\phi_X^s)^{-1}.$$

When X does not depend on the time, then ϕ_X^t is the usual flow and

$$\Phi_X^{t,s} = \phi_X^{t-s}.$$

A time-dependent vector field $X = \{X_t\}_{t \in I}$ is called **complete** if its flow Φ_X is defined on $M \times I \times I$. We have the standard result that compactly supported, time-independent vector fields are complete. However, the naive extension of this result to time-dependent vector fields $X = \{X_t\}_{t \in I}$ fails: it does not suffice that each X_t is compactly supported.

Example A.11. Fix two smooth functions with the following properties:

- (i) $u : [0, 1] \rightarrow \mathbb{R}$ such that $\lim_{t \rightarrow 1} u(t) = \infty$.
- (ii) $\chi : \mathbb{R} \rightarrow [0, 1]$ such that $\chi(0) = 1$ and $\text{supp}(\chi) = [-1, 1]$.

Then the time-dependent vector field $X = \{X_t\}_{t \in [0,1]}$ on \mathbb{R} , defined by

$$X_t(x) := \begin{cases} u'(t) \cdot \chi(x - u(t)) \frac{\partial}{\partial x} & \text{if } 0 \leq t < 1, \\ 0 & \text{if } t = 1 \end{cases}$$

has the property that $\text{supp}(X_t) = [u(t) - 1, u(t) + 1]$, for $t < 1$ and $\text{supp}(X_1) = \emptyset$; in particular, it is compact. However, X is not complete: the integral curve $\gamma(t) = u(t)$ goes to infinity as $t \rightarrow 1$. 

A time-dependent vector field $X = \{X_t\}_{t \in I}$ is called **compactly supported** if

$$\text{supp}(X) \cap (M \times [a, b]) \subset M \times I$$

is compact for any compact interval $[a, b] \subset I$ or, in other words, provided that the projection $\text{pr}_I : \text{supp}(X) \rightarrow I$ is proper. Using the correspondence above between time-dependent and time-independent vector fields, one obtains:

Proposition A.12. *Any compactly supported time-dependent vector field is complete.*

The following useful proposition already shows how time-dependent vector fields become relevant for us:

Proposition A.13. *Let $\mathfrak{a} : \mathfrak{g} \rightarrow \mathfrak{X}(M)$ be an infinitesimal action. Given $x, y \in M$, there exist $v_1, \dots, v_k \in \mathfrak{g}$ such that*

$$y = \phi_{\mathfrak{a}(v_1)}^1 \cdots \phi_{\mathfrak{a}(v_k)}^1(x)$$

if and only if there exists a smooth curve $v : [0, 1] \rightarrow \mathfrak{g}$ such that for the resulting time-dependent vector field $\{\mathfrak{a}(v_t)\}_{t \in [0,1]}$, we have

$$y = \phi_{\mathfrak{a}(v_t)}^1(x) = \Phi_{\mathfrak{a}(v_t)}^{1,0}(x).$$

Moreover, if \mathfrak{a} is induced by an action of a connected Lie group G , then these conditions are also equivalent to x and y belonging to the same G -orbit.

For an infinitesimal action $\mathfrak{a} : \mathfrak{g} \rightarrow \mathfrak{X}(M)$, define the **orbit** of x as

$$(A.13) \quad \mathcal{O}_x := \{y = \phi_{\mathfrak{a}(v_t)}^1(x) : \text{for some smooth curve } v : [0, 1] \rightarrow \mathfrak{g}\}.$$

One can show that $\mathcal{O}_x \subset M$ is an immersed submanifold of dimension:

$$\dim \mathcal{O}_x = \dim \mathfrak{g} - \dim \mathfrak{g}_x.$$

The orbits form a partition of M by initial submanifolds called the **orbit foliation** of the Lie algebra action.

We will also need to know the effect of the flow of a time-dependent vector field on a differential form. For that, recall that the **Lie derivative** along a time-dependent vector field $X = \{X_t\}_{t \in I}$ of a differential form $\eta \in \Omega^\bullet(M)$ is given by

$$\mathcal{L}_{X_t}\eta := \left. \frac{d}{d\varepsilon} \right|_{\varepsilon=0} (\Phi_X^{t+\varepsilon,t})^* \eta.$$

We also have **Cartan's magic formula**

$$\mathcal{L}_{X_t}\eta = di_{X_t}\eta + i_{X_t}d\eta,$$

which shows that the Lie derivative of a time-dependent vector field $X = \{X_t\}_{t \in I}$ coincides with the t -family of Lie derivatives of each vector field X_t .

The following formula is also very useful:

Lemma A.14. *Given a time-dependent vector field $\{X_t\}_{t \in I}$, $0 \in I$, with flow $\phi_X^t := \Phi_X^{t,0}$, and a time-dependent differential form $\{\omega_t\}_{t \in I}$, one has*

$$\frac{d}{dt} (\phi_X^t)^* \omega_t = (\phi_X^t)^* \left(\frac{d}{dt} \omega_t + \mathcal{L}_{X_t} \omega_t \right).$$

Symplectic Structures

Symplectic structures appear throughout this book: they are examples of Poisson structures, the leaves of Poisson manifolds carry symplectic forms, the global objects integrating Poisson manifolds are symplectic, etc. We collect here some basic results from symplectic geometry. For an elementary introduction to symplectic geometry see the lectures notes by Cannas da Silva [29]. A much more advanced and comprehensive text, also going into symplectic topology, is the monograph by McDuff and Salamon [118].

B.1. Symplectic forms

Recall that a 2-form $\omega \in \Omega^2(M)$ determines a vector bundle map:

$$(B.1) \quad \omega^\flat : TM \rightarrow T^*M, \quad X \mapsto i_X\omega.$$

The **rank of** ω at $x \in M$ is, by definition, the dimension of the image of this map. We call ω **nondegenerate** if $\text{rank } \omega_x = \dim M$ for all $x \in M$.

Definition B.1. A **symplectic manifold** is a manifold M together with a closed, nondegenerate 2-form $\omega \in \Omega^2(M)$.

A **symplectic map** between two symplectic manifolds (M_1, ω_1) and (M_2, ω_2) is a smooth map $\Phi : M_1 \rightarrow M_2$ that satisfies $\Phi^*\omega_2 = \omega_1$.

A symplectic diffeomorphism is also called a **symplectomorphism**.

The condition that ω be nondegenerate ensures that, given $H \in C^\infty(M)$, there is a unique vector field $X_H \in \mathfrak{X}(M)$, called the **Hamiltonian vector field** of H , such that

$$(B.2) \quad i_{X_H}\omega = dH.$$

The set of all such vector fields will be denoted

$$(B.3) \quad \mathfrak{X}_{\text{Ham}}(M, \omega) \subset \mathfrak{X}(M).$$

An important property of Hamiltonian vector fields is that their flow preserves ω :

$$\mathcal{L}_{X_H}\omega = d(i_{X_H}\omega) + i_{X_H}(d\omega) = d(dH) + i_{X_H}(0) = 0.$$

More generally, a **symplectic vector field** is a vector field $X \in \mathfrak{X}(M)$ whose flow preserves ω . We denote the collection of all such vector fields by

$$\mathfrak{X}(M, \omega) := \{X \in \mathfrak{X}(M) : \mathcal{L}_X\omega = 0\}.$$

These two form Lie subalgebras in the Lie algebra of all vector fields:

$$\mathfrak{X}_{\text{Ham}}(M, \omega) \subset \mathfrak{X}(M, \omega) \subset \mathfrak{X}(M).$$

Exercise B.2. Show that the Lie bracket of any two symplectic vector fields X and Y is a Hamiltonian vector field. More precisely, show that

$$[X, Y] = -X_{\omega(X, Y)}.$$

Of central importance are the integral curves γ of Hamiltonian vector fields X_H , i.e., the solutions of the equation

$$\dot{\gamma}(t) = X_H(\gamma(t)).$$

Given H , a function $f \in C^\infty(M)$ is called a **first integral** of X_H if f is constant along the integral curves of X_H or, equivalently, $\mathcal{L}_{X_H}(f) = 0$. The fact that this condition is symmetric in f and H , as well as other properties of first integrals, is best understood using the resulting bracket.

Definition B.3. Given a symplectic manifold (M, ω) , the **Poisson bracket** of two functions $f, g \in C^\infty(M)$ is defined as

$$\{f, g\} := X_f(g).$$

It is a simple exercise to check that the Poisson bracket is a Lie bracket:

Proposition B.4. *On any symplectic manifold (M, ω) , the induced bracket*

$$\{\cdot, \cdot\} : C^\infty(M) \times C^\infty(M) \rightarrow C^\infty(M)$$

is a Lie bracket (i.e., it is skew-symmetric and satisfies the Jacobi identity) and, furthermore, it satisfies the Leibniz identity in each argument:

$$\{f, gh\} = g\{f, h\} + \{f, g\}h, \quad \forall f, g, h \in C^\infty(M).$$

Corollary B.5. *For a symplectic manifold (M, ω) the map $C^\infty(M) \rightarrow \mathfrak{X}_{\text{Ham}}(M, \omega)$, $f \mapsto X_f$, is a Lie algebra homomorphism:*

$$[X_f, X_g] = X_{\{f, g\}}, \quad \forall f, g \in C^\infty(M).$$

Any symplectic manifold (M, ω) comes with a canonical volume form, called the **Liouville volume form**,

$$\mu_L = \frac{\omega^s}{s!} \quad (2s = \dim M).$$

The Liouville volume form is invariant under Hamiltonian flows. In particular, symplectic manifolds are oriented.

Example B.6. The “canonical” example of symplectic manifold is \mathbb{R}^{2s} with linear coordinates $(q^1, \dots, q^s, p_1, \dots, p_s)$ and symplectic form:

$$(B.4) \quad \omega_{\text{can}} := \sum_{i=1}^s dq^i \wedge dp_i.$$

The induced Poisson bracket on $C^\infty(M)$ is simply

$$\{f, g\} := \sum_{i=1}^s \left(\frac{\partial f}{\partial p_i} \frac{\partial g}{\partial q^i} - \frac{\partial f}{\partial q^i} \frac{\partial g}{\partial p_i} \right).$$

In particular, we find that the Poisson brackets of the coordinates are

$$\{q^i, q^j\} = \{p_i, p_j\} = 0, \quad \{p_i, q^j\} = \delta_i^j.$$

For $H \in C^\infty(M)$, the equations for the integral curves of X_H are the classical equations of Hamilton

$$(B.5) \quad \begin{cases} \dot{q}^i = \{H, q^i\} = \frac{\partial H}{\partial p_i}, \\ \dot{p}_i = \{H, p_i\} = -\frac{\partial H}{\partial q^i} \end{cases} \quad (i = 1, \dots, s).$$

In particular, when $H = \frac{1}{2} \sum_{i=1}^s p_i^2 + V(q^1, \dots, q^n)$, one obtains Newton’s equations for the motion of a particle in a potential V

$$\ddot{q}^i = -\frac{\partial V}{\partial q^i} \quad (i = 1, \dots, s). \quad \text{🐟}$$

The first basic fact about symplectic manifolds is that locally they all look the same:

Theorem B.7 (Darboux’s Theorem). *For any symplectic manifold (M, ω) , around any point $x \in M$ one can find a chart $(U, q^1, \dots, q^s, p_1, \dots, p_s)$ with respect to which ω takes the canonical form (B.4).*

Such a chart is called a **Darboux chart** for ω .

Darboux’s Theorem leads to an alternative characterization of symplectic manifolds in terms of a symplectic atlas. A symplectic manifold of dimension $2s$ is a manifold M with an atlas $\{(U_i, \phi_i) : i \in I\}$ such that the transition functions $\phi_j \circ \phi_i^{-1}$ are symplectomorphisms between open subsets of $(\mathbb{R}^{2s}, \omega_{\text{can}})$.

Although Darboux's Theorem shows that a symplectic manifold (M, ω) has no local invariants, besides its dimension, there are global invariants. One such invariant is the cohomology class of the symplectic form. The relevance of this class is made clear in the following very useful result:

Theorem B.8 (Moser's Lemma). *Let M be a compact manifold, and let $\{\omega_t\}_{t \in [0,1]}$ be a smooth path of symplectic structures on M such that the class $[\omega_t] \in H^2(M)$ is constant. Then (M, ω_0) and (M, ω_1) are symplectomorphic.*

We note, however, that there are examples of compact manifolds M with two symplectic forms ω and ω' representing the same cohomology class, but which are not symplectomorphic. Noncompact examples are even easier to construct: \mathbb{R}^2 with ω_{can} and $\omega' = \frac{1}{(x^2+y^2+1)^2} dx \wedge dy$ are not symplectomorphic, simply because the second form has a finite volume. On the other hand, it has been shown by Gromov that \mathbb{R}^4 admits more "exotic" symplectic structures, which are not symplectomorphic to ω_{can} and still have infinite volume — see [118].

Let us recall some interesting classes of symplectic structures.

Example B.9 (Cotangent bundles). For any manifold M , the cotangent bundle T^*M carries a canonical symplectic form ω_{can} . It can be obtained by gluing together bits of the canonical one on \mathbb{R}^{2s} as follows. Recall that for each chart (U, q^1, \dots, q^s) on M one has a chart $(T^*U, q^1, \dots, q^s, p_1, \dots, p_s)$ on T^*M by setting

$$T^*U \ni (x, p_1 dx q^1 + \dots + p_s dx q^s) \mapsto (q^1(x), \dots, q^s(x), p_1, \dots, p_s) \in \mathbb{R}^{2s}.$$

Pulling back the canonical symplectic form (B.4) along such a chart, one obtains a symplectic form on T^*U . A direct computation shows that on overlaps of such charts the two forms coincide. In other words, we obtain a global canonical symplectic form

$$\omega_{\text{can}} \in \Omega^2(T^*M).$$

One can also give an intrinsic description of ω_{can} . Namely,

$$(B.6) \quad \omega_{\text{can}} = -d\theta_L,$$

where $\theta_L \in \Omega^1(T^*M)$ is the so-called **Liouville 1-form**, defined as follows. For a vector $v \in T_\xi(T^*M)$, where $\xi \in T_x^*M$, we have that $d_\xi \text{pr}(v) \in T_x M$, and so we define

$$\theta_L(v) := \xi(d_\xi \text{pr}(v)).$$

The Liouville form is characterized by the property

$$\alpha^* \theta_L = \alpha, \quad \forall \alpha \in \Omega^1(M),$$

where on the left side we view α as a map $\alpha : M \rightarrow T^*M$. From this it follows that the canonical symplectic form $\omega_{\text{can}} \in \Omega^2(T^*M)$ is characterized by the property

$$\alpha^* \omega_{\text{can}} = -d\alpha, \quad \forall \alpha \in \Omega^1(M). \quad \text{🐟}$$

Example B.10 (Coadjoint orbits). Another general class of symplectic manifolds is that of coadjoint orbits $\mathcal{O} \subset \mathfrak{g}^*$ of a connected Lie group G . Here we use the notation and the discussion from Example A.7. We claim that there is a canonical symplectic structure

$$\omega_{\mathcal{O}} \in \Omega^2(\mathcal{O}).$$

To describe it at an arbitrary $\xi \in \mathcal{O}$ we use the infinitesimal action (A.9)

$$a_{\xi} : \mathfrak{g} \rightarrow T_{\xi}\mathcal{O}, \quad a(v)_{\xi} = (\text{ad}_v^*)_{\xi}$$

to represent tangent vectors to \mathcal{O} and we define

$$\omega_{\mathcal{O}}(a(v)_{\xi}, a(w)_{\xi}) := -\xi([v, w]).$$

The fact that a_{ξ} is surjective with kernel the isotropy Lie algebra

$$\mathfrak{g}_{\xi} = \{v \in \mathfrak{g} : \text{ad}_v^*(\xi) = 0\}$$

implies that $\omega_{\mathcal{O}}$ is well-defined and is a nondegenerate 2-form on \mathcal{O} .

To check that $\omega_{\mathcal{O}}$ is closed, we pull it up to G via the quotient map

$$p_{\xi} : G \rightarrow \mathcal{O}, \quad g \mapsto \text{Ad}_g^* \xi,$$

where $\xi \in \mathcal{O}$ is fixed. The resulting 2-form on G

$$p_{\xi}^*(\omega_{\mathcal{O}}) \in \Omega^2(G)$$

is characterized by being left-invariant and the value it takes at the identity:

$$p_{\xi}^*(\omega_{\mathcal{O}})(v, w) = -\xi([v, w]), \quad \forall v, w \in \mathfrak{g}.$$

The previous equation yields

$$p_{\xi}^*(\omega_{\mathcal{O}}) = d \overleftarrow{\xi},$$

where $\overleftarrow{\xi} \in \Omega^1(G)$ is the left-invariant extension of ξ . This shows that $\omega_{\mathcal{O}}$ is closed, hence a symplectic form on \mathcal{O} . 🐟

B.2. Symplectic and Hamiltonian actions

A **symplectic action** is a smooth action of a Lie group G on a symplectic manifold (M, ω) by symplectomorphisms:

$$\mathcal{A} : G \rightarrow \text{Diff}(M), \quad \mathcal{A}_g^* \omega = \omega, \quad \forall g \in G.$$

Exercise B.11. Assume that G acts symplectically on (M, ω) . Also assume that the action is free and proper, so that M/G is smooth — see Theorem A.9 — and we can identify $C^\infty(M/G)$ with the subalgebra of G -invariant smooth functions $C^\infty(M)^G \subset C^\infty(M)$. Show that $C^\infty(M)^G$ is closed under the Poisson bracket $\{\cdot, \cdot\}$ associated to ω and that the resulting operation

$$\{\cdot, \cdot\} : C^\infty(M/G) \times C^\infty(M/G) \rightarrow C^\infty(M/G)$$

has the same properties as in Proposition B.4.

The conclusion of the previous exercise is that, although M/G might not be a symplectic manifold, it still always carries a “Poisson bracket”.

Example B.12. Important examples of symplectic actions are provided by taking coadjoint orbits $\mathcal{O} \subset \mathfrak{g}^*$ of a connected Lie group G , endowed with the canonical symplectic structure $\omega_{\mathcal{O}}$ from Example B.10. For example, the sphere \mathbb{S}^2 with the usual area form is symplectomorphic to a coadjoint orbit of $G = SO(3)$. More generally, among the coadjoint orbits of $G = SU(n+1)$ one finds $\mathbb{C}\mathbb{P}^n$ with the so-called Fubini-Study symplectic form. 

The infinitesimal action induced by a symplectic action is by symplectic vector fields. In general, a **symplectic infinitesimal action** of a Lie algebra \mathfrak{g} on a symplectic manifold (M, ω) is a Lie algebra homomorphism

$$\mathfrak{a} : \mathfrak{g} \rightarrow \mathfrak{X}(M, \omega).$$

It is natural to consider actions \mathfrak{a} that take values in the subalgebra of Hamiltonian vector fields $\mathfrak{X}_{\text{Ham}}(M, \omega) \subset \mathfrak{X}(M, \omega)$. Since a Hamiltonian vector field X_H determines the function H only up to a constant, one usually fixes a linear map $\mu : \mathfrak{g} \rightarrow C^\infty(M)$, $v \mapsto \mu_v$, which is a lift of the action \mathfrak{a} :

$$\begin{array}{ccc} & C^\infty(M) & \\ & \nearrow \mu & \downarrow \text{Ham} \\ \mathfrak{g} & \xrightarrow{\mathfrak{a}} \mathfrak{X}_{\text{Ham}}(M, \omega) & \end{array} \quad \mathfrak{a}(v) = X_{\mu_v}.$$

Definition B.13. A **\mathfrak{g} -Hamiltonian space** is a symplectic manifold (M, ω) together with a Lie algebra homomorphism

$$\mu : (\mathfrak{g}, [\cdot, \cdot]) \rightarrow (C^\infty(M), \{\cdot, \cdot\}), \quad v \mapsto \mu_v,$$

where $C^\infty(M)$ carries the Poisson bracket from Definition B.3. The corresponding infinitesimal \mathfrak{g} -action is defined by $\mathfrak{a}(v) := X_{\mu_v}$.

At the global level one has the notion of a G -Hamiltonian space.

Definition B.14. A G -Hamiltonian space is a symplectic manifold (M, ω) with a symplectic action of G and a linear map, called the **moment map**,

$$(B.7) \quad \mu : \mathfrak{g} \rightarrow C^\infty(M), \quad v \mapsto \mu_v,$$

which is G -equivariant and satisfies

$$(B.8) \quad i_{\mathfrak{a}(v)}\omega = d\mu_v.$$

Some comments are in order. First of all, it is more common to view the moment map as a map $\mu : M \rightarrow \mathfrak{g}^*$. One has $\mu_v(x) = \langle \mu(x), v \rangle$, where $\langle \cdot, \cdot \rangle : \mathfrak{g}^* \times \mathfrak{g} \rightarrow \mathbb{R}$ is the evaluation map. Often we will denote a G -Hamiltonian space schematically by

$$(B.9) \quad \mu : (M, \omega) \rightarrow \mathfrak{g}^*.$$

The G -equivariance of μ is with respect to the adjoint action and the given symplectic action $\mathcal{A} : G \times M \rightarrow M$:

$$\mu_v \circ \mathcal{A}_{g^{-1}} = \mu_{\text{Ad}_g(v)}.$$

In the reinterpretation (B.9), the G -equivariance is expressed in terms of the coadjoint action:

$$\mu(g \cdot x) = \text{Ad}_g^*(\mu(x)).$$

The infinitesimal counterpart of G -equivariance is obtained by setting $g = \exp(tu)$ and differentiating at $t = 0$. One obtains

$$(B.10) \quad \mathcal{L}_{\mathfrak{a}(u)}(\mu_v) = \mu_{[u,v]}, \quad \forall u, v \in \mathfrak{g}.$$

Exercise B.15. Show that the infinitesimal equivariance condition (B.10) is equivalent to the moment map $\mu : \mathfrak{g} \rightarrow C^\infty(M)$ being a Lie algebra morphism:

$$\mu_{[u,v]} = \{\mu_u, \mu_v\}, \quad \forall u, v \in \mathfrak{g}.$$

Thus, any G -Hamiltonian space is also a \mathfrak{g} -Hamiltonian space. Conversely, one can show that a complete \mathfrak{g} -Hamiltonian action integrates to a G -Hamiltonian action of the 1-connected group G integrating \mathfrak{g} .

Example B.16 (Abelian actions). For an S^1 -Hamiltonian action on (M, ω) the infinitesimal action is encoded by the vector field $V \in \mathfrak{X}(M)$

$$V_x = \left. \frac{d}{dt} \right|_{t=0} e^{-it} x.$$

The condition that the infinitesimal action is symplectic,

$$\mathcal{L}_V \omega = 0,$$

is equivalent to $i_V\omega$ being closed. On the other hand, the requirement that the infinitesimal action is Hamiltonian amounts to $i_V\omega$ being exact:

$$i_V\omega = d\mu,$$

for some smooth function $\mu \in C^\infty(M)$. Note that the equivariance of μ is automatic. A similar discussion applies to the n -dimensional torus $G = \mathbb{T}^n$.

Example B.17 (Exact symplectic manifolds and lifted actions on cotangent bundles). Let (M, ω) be an exact symplectic manifold; i.e., $\omega = d\theta$. Assume that G is a Lie group that acts on M preserving the primitive θ :

$$\mathcal{A}_g^*\theta = \theta.$$

Then one obtains a G -Hamiltonian space with moment map

$$\mu : M \rightarrow \mathfrak{g}^*, \quad \mu_v = -i_{\mathfrak{a}(v)}\theta, \quad \forall v \in \mathfrak{g}.$$

Indeed, the moment map condition follows by observing that

$$\begin{aligned} \mathcal{L}_{\mathfrak{a}(v)}\theta = 0 &\iff di_{\mathfrak{a}(v)}\theta + i_{\mathfrak{a}(v)}d\theta = 0 \\ &\iff i_{\mathfrak{a}(v)}\omega = -di_{\mathfrak{a}(v)}\theta = d\mu_v \end{aligned}$$

and the G -equivariance follows because θ is G -invariant.

Let us apply this to a cotangent bundle $M = T^*N$ equipped with the canonical symplectic form $\omega_{\text{can}} = -d\theta_L$. A Lie group action $\mathcal{A} : G \times N \rightarrow N$ naturally lifts to an action on the cotangent bundle:

$$\tilde{\mathcal{A}} : G \times T^*N \rightarrow T^*N, \quad \tilde{\mathcal{A}}_g\alpha := (\mathcal{A}_{g^{-1}})^*\alpha.$$

The lifted action preserves the Liouville 1-form θ_L . Hence, we obtain a Hamiltonian action with moment map

$$\mu : T^*N \rightarrow \mathfrak{g}^*, \quad \mu_v = i_{\tilde{\mathfrak{a}}(v)}\theta_L.$$

The definition of θ_L shows that μ is just the dual of the action $\mathfrak{a} : \mathfrak{g} \rightarrow \mathfrak{X}(N)$:

$$\langle \mu(\alpha), v \rangle = i_{\mathfrak{a}(v)}\alpha,$$

which can be abbreviated to $\mu = \mathfrak{a}^*$. 

While the quotient of a symplectic manifold by a proper and free symplectic action is typically not symplectic, Hamiltonian actions can be used to produce symplectic quotients. Given a G -Hamiltonian space

$$\mu : (M, \omega) \rightarrow \mathfrak{g}^*,$$

its **symplectic quotient**, also called the Marsden-Weinstein reduction at $\xi = 0$, is the quotient

$$M // G := \mu^{-1}(0)/G.$$

To ensure that $M//G$ is a smooth manifold, we make the following regularity assumptions (see Theorem A.9):

- (i) $0 \in \mathfrak{g}^*$ is a regular value of μ .
- (ii) The action of G on $\mu^{-1}(0)$ is free and proper.

Exercise B.18. Show that the condition that the action of G on $\mu^{-1}(0)$ is free implies that 0 is a regular value of μ .

Theorem B.19. *Under the previous assumptions, $M//G$ carries a canonical symplectic form ω_0 . The form ω_0 is uniquely determined by the condition*

$$p_0^* \omega_0 = i_0^* \omega,$$

where $p_0 : \mu^{-1}(0) \rightarrow M//G$ is the quotient map and $i_0 : \mu^{-1}(0) \rightarrow M$ is the inclusion.

Similarly, the reduced symplectic space at an arbitrary point $\xi \in \mathfrak{g}^*$ is defined as the quotient

$$M//_\xi G := \mu^{-1}(\xi)/G_\xi,$$

where $G_\xi \subset G$ is the isotropy group of ξ for the coadjoint action. Under similar regularity assumptions, this is also a symplectic manifold with symplectic form ω_ξ uniquely determined by the condition

$$p_\xi^* \omega_\xi = i_\xi^* \omega,$$

where $p_\xi : \mu^{-1}(\xi) \rightarrow M//_\xi G$ is the projection and $i_\xi : \mu^{-1}(\xi) \rightarrow M$ is the inclusion.

A slightly different approach to these reduced spaces is as follows. First, using the equivariance of the moment map, one obtains a similar map on the ordinary quotients

$$\hat{\mu} : M/G \rightarrow \mathfrak{g}^*/G$$

taking values in the space of coadjoint orbits. The fibers of $\hat{\mu}$ give a partition of M/G parametrized by the coadjoint orbits $\mathcal{O} \subset \mathfrak{g}^*$. Each fiber can be further “simplified” by choosing $\xi \in \mathcal{O}$:

$$\hat{\mu}^{-1}(\mathcal{O}) = \mu^{-1}(\mathcal{O})/G \simeq \mu^{-1}(\xi)/G_\xi.$$

In other words, the reduction at the different $\xi \in \mathfrak{g}^*$ are the members of a natural partition of the ordinary quotient M/G . Since ω is G -invariant, for different values $\xi_1, \xi_2 \in \mathcal{O}$ the forms ω_{ξ_1} and ω_{ξ_2} correspond to each other under the natural isomorphism:

$$\mu^{-1}(\xi_1)/G_{\xi_1} \simeq \mu^{-1}(\xi_2)/G_{\xi_2}.$$

So we have a well-defined symplectic form $\omega_{\mathcal{O}}$ on

$$(B.11) \quad M//_{\mathcal{O}} G := \mu^{-1}(\mathcal{O})/G.$$

One should be aware of the fact that, in general, the pullback of $\omega_{\mathcal{O}}$ to $\mu^{-1}(\mathcal{O})$ does not coincide with the restriction of ω .

Example B.20 (Fubini-Study symplectic form). Consider the \mathbb{S}^1 -action on $(\mathbb{C}^{n+1}, \omega_{\text{can}})$ defined by

$$\theta \cdot (z_0, \dots, z_n) = (e^{i\theta} z_0, \dots, e^{i\theta} z_n),$$

which has moment map

$$\mu : \mathbb{C}^{n+1} \rightarrow \mathbb{R}, \quad \mu(z_0, \dots, z_n) = \frac{1}{2} \left(1 - \sum_{i=0}^n z_i \bar{z}_i \right).$$

We then find that

$$\mu^{-1}(0)/\mathbb{S}^1 = \mathbb{C}^{n+1} // \mathbb{S}^1 = \mathbb{C}\mathbb{P}^n.$$

The induced symplectic structure on $\mathbb{C}\mathbb{P}^n$ is called the Fubini-Study symplectic form. 

Example B.21. Let us consider the cotangent lift of a G -action $G \times N \rightarrow N$ as in Example B.17. If the action is proper and free, the lifted action is proper and free, and the moment map $\mu : T^*N \rightarrow \mathfrak{g}^*$ is a submersion. In this case one finds that the symplectic quotient at level zero is naturally isomorphic to a cotangent bundle:

$$T^*N // G \simeq T^*(N/G), \quad \omega_0 = \omega_{\text{can}}.$$

The symplectic quotients at nonzero values need not be cotangent bundles anymore. For example, take $N = G$, and let G act on itself by right translations — remember our actions are always left actions:

$$\mathcal{A} : G \times G \rightarrow G, \quad (g, h) \mapsto hg^{-1}.$$

Then, via the identification of T^*G with $G \times \mathfrak{g}^*$ using left translations, the lifted cotangent action becomes

$$\tilde{\mathcal{A}} : G \times (G \times \mathfrak{g}^*) \rightarrow G \times \mathfrak{g}^*, \quad (g, (h, \alpha)) \mapsto (hg^{-1}, \text{Ad}_g^* \alpha),$$

while the moment map becomes the second projection $\mu : G \times \mathfrak{g}^* \rightarrow \mathfrak{g}^*$. Hence, for the reduced spaces we obtain

$$T^*G //_{\epsilon} G = \mu^{-1}(\mathcal{O}_{\epsilon})/G \cong \mathcal{O}_{\epsilon}.$$

We leave it to the reader to check that the resulting symplectic structure coincides with the natural one discussed in Example B.10. 

Foliations

For an introduction to foliation theory in the spirit of this book, see the monograph by Moerdijk and Mrčun [122]. A more detailed account of foliation theory can be found in the two-volume monograph by Candel and Conlon [27, 28]. Our treatment of singular foliations is in the spirit of the paper of Androulidakis and Skandalis [10].

C.1. Regular foliations

Definition C.1. A **foliation** of codimension q on a manifold M is a partition \mathcal{F} of M into immersed connected submanifolds of codimension q ,

$$M = \bigcup_{L \in \mathcal{F}} L,$$

satisfying the following local triviality property: every point in M has an open neighborhood U such that

$$\mathcal{F}|_U := \{\text{connected component of } L \cap U : L \in \mathcal{F}\}$$

coincides with the partition by the fibers of a submersion $f : U \rightarrow \mathbb{R}^q$.

One calls the submanifolds L the **leaves** of the foliation \mathcal{F} and $p = \dim(L)$ the **dimension** of \mathcal{F} , so that $p + q = \dim(M)$.

Due to the local normal form of submersions, the local triviality property in the definition is equivalent to requiring each point to belong to a chart

$$\chi : U \xrightarrow{\simeq} V \times W, \quad V \subset \mathbb{R}^p, \quad W \subset \mathbb{R}^q \text{ open subsets,}$$

with the property that $\mathcal{F}|_U$ corresponds to the partition of $V \times W$ by $V \times \{w\}$ with $w \in W$. Such charts are usually called **foliated charts** for \mathcal{F} .

Foliations can be approached from an infinitesimal point of view:

Definition C.2. A **distribution** on a manifold M is a vector sub-bundle

$$\mathcal{D} \subset TM.$$

A distribution \mathcal{D} is called **involutive** if

$$[X, Y] \in \Gamma(\mathcal{D}), \quad \forall X, Y \in \Gamma(\mathcal{D}).$$

An important, basic, result is the following:

Theorem C.3 (Global Frobenius). *For any manifold M , there is a 1-to-1 correspondence*

$$\left\{ \text{foliations } \mathcal{F} \text{ on } M \right\} \xleftrightarrow{\sim} \left\{ \text{involutive distributions } \mathcal{D} \subset TM \right\}.$$

In one direction, the correspondence works as follows: a foliation \mathcal{F} defines the involutive distribution $\mathcal{D} := T\mathcal{F}$, where for $x \in M$ the subspace $\mathcal{D}_x = T_x\mathcal{F} \subset T_xM$ consists of vectors tangent to the leaf L through x :

$$(C.1) \quad T_x\mathcal{F} := T_xL.$$

In the other direction, given an involutive distribution \mathcal{D} , to recover the partition \mathcal{F} such that $T\mathcal{F} = \mathcal{D}$ there are several ways one can proceed. For example:

- (i) One can mimic the construction of the flow of a vector field: one calls an integral submanifold of \mathcal{D} any connected immersed submanifold $L \subset M$ satisfying $T_xL = \mathcal{D}_x$ for all $x \in L$, then proves their existence locally, and finally passes to maximal ones. The maximal integral submanifolds will be precisely the leaves of \mathcal{F} .
- (ii) One can describe the leaves set-theoretically right away, by declaring that two points $x, y \in M$ are in the same leaf L if and only if there exists a path $\gamma : [0, 1] \rightarrow M$ joining them ($\gamma(0) = x, \gamma(1) = y$) and everywhere tangent to \mathcal{D} :

$$\dot{\gamma}(t) \in \mathcal{D}_{\gamma(t)}, \quad \forall t \in [0, 1].$$

Then one needs to show that these sets carry smooth structures that make them into immersed submanifolds.

Below, we will describe yet another approach. However, in all of them, there is something nontrivial to prove: e.g., the local analysis of integral submanifolds in the first approach, or the smooth structure on the leaves in the second approach, or the local triviality of the resulting partition in

both approaches. The key ingredient in doing so is the local version of the Frobenius Theorem:

Theorem C.4 (Local Frobenius). *For any involutive distribution $\mathcal{D} \subset TM$ of rank p , there is a chart $(U, \chi = (x^1, \dots, x^n))$ around each point such that*

$$(C.2) \quad \mathcal{D}|_U = \text{Span} \left\langle \frac{\partial}{\partial x^1}, \dots, \frac{\partial}{\partial x^p} \right\rangle.$$

Charts of the type

$$\chi : U \xrightarrow{\sim} V \times W, \quad V \subset \mathbb{R}^p, \quad W \subset \mathbb{R}^q \text{ open and connected,}$$

satisfying (C.2) can be turned into foliated charts, therefore realizing $\mathcal{D} = T\mathcal{F}$ for some foliation \mathcal{F} . More precisely, one can talk about the **plaques** of \mathcal{D} with respect to such a chart: they are the pre-images

$$U_w(\chi) := \chi^{-1}(V \times \{w\}) \quad (w \in W).$$

Since V is connected, each plaque sits inside a leaf — defined using paths tangent to \mathcal{D} as above — and the restrictions of χ to the plaques,

$$\chi|_{U_w(\chi)} : U_w(\chi) \xrightarrow{\sim} V,$$

serve now as charts for the leaves. One can then prove that the leaves become smooth immersed submanifolds. The local triviality for \mathcal{F} follows right away since, by construction, these charts become foliated charts.

Incidentally, let us point out that the leaves are more commonly constructed using plaques instead of paths: two points $x, y \in M$ are in the same leaf if and only if there exist points $x_0 = x, x_1, \dots, x_k, x_{k+1} = y$ such that any two consecutive points belong to the same plaque.

Example C.5 (Simple foliations). On an n -dimensional manifold M , there are two obvious examples of foliations:

- (i) \mathcal{F} is the partition by connected components of M , so $T\mathcal{F} = TM$.
- (ii) The partition \mathcal{F} by points, so $T\mathcal{F} = 0$.

These are both examples of **simple foliations** by which we mean a foliation \mathcal{F} of M given by the fibers of a submersion $p : M \rightarrow B$ with connected fibers. In this case, $T\mathcal{F} = \text{Ker } dp$, $\dim \mathcal{F} = \dim M - \dim B$, and $\text{codim } \mathcal{F} = \dim B$. Equivalently, these are precisely the foliations for which the space of leaves is smooth, in the sense that it admits a smooth structure — necessarily unique — making the canonical projection into a submersion. 

Example C.6 (Codimension-1 foliations). Already in codimension 1, foliations can exhibit quite complicated behavior. A codimension 1 distribution $\mathcal{D} \subset TM$ is said to be **transversely orientable** if the line bundle TM/\mathcal{D}

is trivializable. This is equivalent to the existence of a nowhere vanishing 1-form $\theta \in \Omega^1(M)$ such that

$$\mathcal{D} = \text{Ker } \theta.$$

The involutivity of \mathcal{D} can be expressed in terms of the 1-form θ as

$$d\theta \wedge \theta = 0.$$

One calls such a 1-form a **completely integrable 1-form**.

A closed, nowhere vanishing 1-form is obviously completely integrable. For example, a simple codimension-1 foliation given by the fibers of a submersion $p : M \rightarrow \mathbb{S}^1$ is induced by $\theta = p^*d\varphi$, where φ is the “angle coordinate” on \mathbb{S}^1 . 

Example C.7 (Orbit foliations). The orbits of an action of a connected Lie group G on a manifold M are connected immersed submanifolds and they form a partition of M . However, the dimension of the orbits may vary. Recall that

$$\dim \mathcal{O}_x = \dim G - \dim G_x.$$

If the dimension of the isotropy groups G_x does not depend on x , then the orbits have equal dimension, and they do form a regular foliation. The associated tangent distribution is the image of the infinitesimal action $\mathfrak{a} : \mathfrak{g} \times M \rightarrow TM$ — which is smooth because \mathfrak{a} has constant rank. Note that involutivity follows directly because the action preserves the Lie bracket.

We already saw before a special instance of this, namely the case of a proper and free action, where the orbit foliation is simple.

For another example, take the action of \mathbb{R} on \mathbb{T}^2 given by

$$t \cdot (\phi^1, \phi^2) = (\phi^1 + t, \phi^2 + t\lambda),$$

where $\lambda \notin \mathbb{Q}$. We obtain a free, nonproper action and the resulting orbit foliation is called the Kronecker foliation of the 2-torus. It fails to be a simple foliation. 

Next, we discuss a very special property of leaves of foliations: although they are not embedded in general, they satisfy the following property:

Definition C.8. An **initial submanifold** of a manifold M is an immersed submanifold $i : N \rightarrow M$ such that for any smooth map $\Phi : P \rightarrow M$ satisfying $\Phi(P) \subset i(N)$ the induced map $i^{-1} \circ \Phi : P \rightarrow N$ is smooth.

Example C.9. Any embedded submanifold is initial. On the other hand, the immersion of the real line in \mathbb{R}^2 as a figure eight is not. 

Proposition C.10. *The leaves of any foliation are initial submanifolds.*

Initial submanifolds are also called *regularly immersed submanifolds* or even *weakly embedded submanifolds*. In general, a subset may be made into an immersed submanifold in more than one way — e.g., the figure eight in \mathbb{R}^2 . However, for initial submanifolds, we have (for a proof see [146]):

Theorem C.11. *Let M be a smooth manifold. If a subset $N \subset M$ admits a smooth structure for which the inclusion $i : N \hookrightarrow M$ is an initial submanifold, then it is unique. Moreover, it is the unique smooth structure on N for which the inclusion is an immersion.*

In particular, given a partition of a manifold M there is at most one choice of smooth structures on the members of the partition making it a foliation. For this reason, one often gives a foliation \mathcal{F} simply by describing the partition of M , without giving detailed information about the smooth structures of the leaves, these being unique.

Another illustration of the fact that initial submanifolds behave very much like embedded submanifolds is the following version of the standard regular value theorem.

Theorem C.12. *Let $S \subset M$ be an initial submanifold, and let $\Phi : N \rightarrow M$ be a smooth map transverse to S :*

$$d_x\Phi(T_xN) + T_{\Phi(x)}S = T_{\Phi(x)}M, \quad \forall x \in \Phi^{-1}(S).$$

Then $\Phi^{-1}(S) \subset N$ is an initial submanifold with

$$T_x\Phi^{-1}(S) = \text{Ker } d_x\Phi \subset T_xN, \quad \forall x \in \Phi^{-1}(S).$$

The same conclusion holds with the transversality condition replaced by the weaker assumption that the dimension of the subspaces $d_x\Phi(T_xN) + T_{\Phi(x)}S$, for $x \in \Phi^{-1}(S)$, is constant.

Proof. The statement is well known for embedded submanifolds — see, e.g., [146]. We derive it for initial ones. For that let $\phi : N \times S \rightarrow M \times M$, $\phi(y, x) := (\Phi(y), x)$, and consider the diagonal $\Delta_M \subset M \times M$. Note that $\text{Im } d\phi + T\Delta_M$ has constant rank, hence

$$G := \phi^{-1}(\Delta_M) = \{(y, x) \in N \times S : \Phi(y) = x\}$$

is an embedded submanifold of $N \times S$, because Δ_M is embedded. We identify G with $\Phi^{-1}(S)$ by $y \mapsto (y, \Phi(y))$, which yields an embedding of $\Phi^{-1}(S)$ into $N \times S$. Projecting in the first factor, this makes the inclusion $\Phi^{-1}(S) \subset N$ into an immersion. We now prove that it is initial. So, let $\Psi : X \rightarrow N$ be a smooth map that takes values in $\Phi^{-1}(S)$. Then

$$X \rightarrow N \times S, \quad x \mapsto (\Psi(x), \Phi(\Psi(x)))$$

is smooth. Since G is embedded, this map is smooth as a map into G ; i.e., Ψ is smooth as a map into $\Phi^{-1}(S)$. □

C.2. Foliated differential forms

One can consider geometric structures on foliations, very much like one considers geometric structures on manifolds, e.g., differential forms, tensors, Riemannian metrics, symplectic structures, etc.

We introduce differential forms on a foliation \mathcal{F} on M . Denote by $\mathfrak{X}(\mathcal{F}) := \Gamma(T\mathcal{F})$ the space of vector fields on M tangent to \mathcal{F} .

Definition C.13. The complex of **foliated forms** is $(\Omega^\bullet(\mathcal{F}), d_{\mathcal{F}})$ where

$$\Omega^k(\mathcal{F}) := \Gamma\left(\bigwedge^k T^*\mathcal{F}\right)$$

and $d_{\mathcal{F}} : \Omega^k(\mathcal{F}) \rightarrow \Omega^{k+1}(\mathcal{F})$ is the foliated de Rham differential

$$\begin{aligned} d_{\mathcal{F}}\omega(X_0, \dots, X_k) &= \sum_{i=0}^k (-1)^i \mathcal{L}_{X_i}(\omega(X_0, \dots, \widehat{X}_i, \dots, X_k)) \\ &\quad + \sum_{0 \leq i < j \leq k} (-1)^{i+j} \omega([X_i, X_j], X_0, \dots, \widehat{X}_i, \dots, \widehat{X}_j, \dots, X_k), \end{aligned}$$

for $X_0, \dots, X_k \in \mathfrak{X}(\mathcal{F})$.

The definition of $d_{\mathcal{F}}$ makes sense because of the involutivity of $T\mathcal{F}$. We have that $d_{\mathcal{F}}^2 = 0$, so one can define the **foliated cohomology** of \mathcal{F} as

$$H^\bullet(\mathcal{F}) = \frac{\text{Ker } d_{\mathcal{F}}}{\text{Im } d_{\mathcal{F}}}.$$

However, one should be aware that these vector spaces, unlike the usual cohomology for manifolds, are often infinite dimensional. Still, they are useful since many foliated cohomology classes encode geometric information.

If $i : L \hookrightarrow M$ is a leaf of \mathcal{F} , then we have the obvious restriction map

$$i^* : \Omega^\bullet(\mathcal{F}) \rightarrow \Omega^\bullet(L),$$

which intertwines the foliated differential on \mathcal{F} with the de Rham differential on L . Notice that a foliated form is closed if and only if it is leafwise closed, i.e., if its restriction to every leaf is closed. The restriction to each leaf of an exact foliated form is exact. However, a foliated form which is leafwise exact need not be an exact foliated form.

A foliated 2-form $\omega \in \Omega^2(\mathcal{F})$ gives a vector bundle map

$$\omega^\flat : T\mathcal{F} \rightarrow T^*\mathcal{F}, \quad X \mapsto i_X\omega.$$

We call ω **nondegenerate** if ω^\flat is an isomorphism.

Definition C.14. A (regular) symplectic foliation is a pair $(\mathcal{F}, \omega_{\mathcal{F}})$, where \mathcal{F} is a foliation and $\omega_{\mathcal{F}}$ is a closed, nondegenerate, foliated 2-form.

The nondegeneracy ensures that given $H \in C^\infty(M)$ there is a unique foliated vector field $X_H \in \mathfrak{X}(\mathcal{F})$, called the **Hamiltonian vector field** of H , such that

$$(C.3) \quad i_{X_H} \omega_{\mathcal{F}} = d_{\mathcal{F}} H.$$

We also have a foliated version of Darboux’s Theorem.

Theorem C.15 (Foliated Darboux). *Let $(\mathcal{F}, \omega_{\mathcal{F}})$ be a symplectic foliation on M . Then M can be covered by foliated charts*

$$(U, q^1, \dots, q^s, p_1, \dots, p_s, y^1, \dots, y^q), \quad \text{where } q = \text{codim}(\mathcal{F}),$$

such that

$$\omega_{\mathcal{F}}|_U = \sum_{i=1}^s dq^i \wedge dp_i.$$

Thus, the theorem provides foliated charts that, at the same time, put the foliated 2-form in Darboux coordinates. Many other results about symplectic manifolds extend to the foliated case.

Symplectic foliations are actually a special class of Poisson manifolds, and they will be treated systematically throughout the book.

Remark C.16 (Foliated versus transversely foliated geometric structures). For a given foliation on a manifold, one can also consider geometric structures transverse to the leaves, which should be thought of as coming from the leaf space. However, in general, this fails to be a manifold.

For example, an **\mathcal{F} -basic form** is a form $\omega \in \Omega^\bullet(M)$ such that

$$\mathcal{L}_X \omega = 0, \quad i_X \omega = 0, \quad \forall X \in T\mathcal{F}.$$

By Cartan’s magic formula, this is equivalent to

$$i_X d\omega = 0, \quad i_X \omega = 0, \quad \forall X \in T\mathcal{F}.$$

The de Rham differential preserves the property of being basic so one has a complex of basic forms $(\Omega_{\mathcal{F}\text{-basic}}^\bullet(M), d)$. If \mathcal{F} is a simple foliation arising from a submersion $p : M \rightarrow B$ with connected fibers, the complex of \mathcal{F} -basic forms is isomorphic to the de Rham complex of B

$$p^* : \Omega^\bullet(B) \xrightarrow{\simeq} \Omega_{\mathcal{F}\text{-basic}}^\bullet(M) \subset \Omega^\bullet(M).$$

Proposition A.10 is an instance of this result.

A **transversely symplectic form** is an \mathcal{F} -basic 2-form

$$\omega \in \Omega_{\mathcal{F}\text{-basic}}^2(M)$$

which is closed and transversely nondegenerate, meaning that

$$\text{Ker } \omega = T\mathcal{F}.$$

Actually, being closed together with the condition on the kernel automatically ensures that the form is basic. When \mathcal{F} is a simple foliation arising from a submersion $\text{pr} : M \rightarrow B$, a form $\omega \in \Omega^2(M)$ is transversely symplectic if and only if $\omega = \text{pr}^* \omega_B$ for a unique symplectic form $\omega_B \in \Omega^2(B)$. This situation will appear throughout the book in the following form:

Proposition C.17. *Let $\omega \in \Omega^2(M)$ be a closed form of constant rank. Then $\text{Ker } \omega$ defines a foliation \mathcal{F} . If \mathcal{F} is simple, then its leaf space B has an induced symplectic structure ω_B such that $\omega = \text{pr}^* \omega_B$.*

Occasionally, we will encounter in the book other geometric objects transverse to the leaves.

C.3. Singular foliations

The symplectic foliation of a Poisson manifold or, more generally, the orbit foliation of a Lie algebroid are examples of *singular foliations*. Here we give a very brief introduction into singular foliations, without many details since we will not use them in the book. Still, we believe that such a discussion gives a useful perspective to some of the material treated in the book.

The notion of singular foliation is more subtle than one may expect at first. There is still an associated partition into leaves, now of varying dimension, but the partition does not carry all the information. The key idea, inspired by the Frobenius Theorem from the regular case, is to characterize singular foliations via the space of vector fields tangent to the leaves. Since there are slightly different ways of looking at spaces of vector fields, we will discuss them first, before giving the formal definition of a singular foliation.

First of all, by a **submodule of vector fields** on a manifold M we mean a $C^\infty(M)$ -submodule of the module of all vector fields

$$\mathcal{V} \subset \mathfrak{X}(M).$$

Such a submodule is called an **involutive submodule** if it is also a Lie subalgebra of $(\mathfrak{X}(M), [\cdot, \cdot])$. Similarly we talk about **submodules of compactly supported vector fields**

$$\mathcal{V} \subset \mathfrak{X}_c(M).$$

For $\mathfrak{X}_c(M)$, the $C_c^\infty(M)$ -submodules are the same thing as the $C^\infty(M)$ -submodules.

A submodule $\mathcal{V} \subset \mathfrak{X}(M)$ as above is called **local** if it satisfies any of the following equivalent conditions:

- (i) If $X \in \mathfrak{X}(M)$ is locally in \mathcal{V} , then $X \in \mathcal{V}$.
- (ii) If $X \in \mathfrak{X}(M)$ satisfies $fX \in \mathcal{V}$ for any $f \in C_c^\infty(M)$, then $X \in \mathcal{V}$.
- (iii) \mathcal{V} is closed under locally finite sums.

Here by X **is locally in** \mathcal{V} we mean that for any $x \in M$ there exists $X^x \in \mathcal{V}$ which coincides with X in a neighborhood of x . The equivalence between these conditions can be easily checked.

Any submodule $\mathcal{V} \subset \mathfrak{X}(M)$ has a corresponding localization $\mathcal{V}^{\text{loc}} \subset \mathfrak{X}(M)$, i.e., the smallest local submodule containing \mathcal{V} . This is the collection of vector fields that are locally in \mathcal{V} , and it can also be described as

$$\begin{aligned} \mathcal{V}^{\text{loc}} &= \left\{ X \in \mathfrak{X}(M) : fX \in \mathcal{V}, \text{ for all } f \in C_c^\infty(M) \right\} \\ &= \left\{ \text{locally finite sums } \sum_i X_i \text{ with } X_i \in \mathcal{V} \right\}. \end{aligned}$$

The notion of local submodule is related to sheaves. We denote by \mathfrak{X}_M the sheaf of vector fields on M , which we view as a sheaf of modules over the sheaf C_M^∞ of smooth functions. Then we can talk about **sheaves of submodules of vector fields** $\mathcal{V} \subset \mathfrak{X}_M$ and we have the following result:

Lemma C.18. *There is a 1-to-1 correspondence between the following:*

- (i) *sheaves of submodules of vector fields $\mathcal{V} \subset \mathfrak{X}_M$,*
- (ii) *local submodules of vector fields $\mathcal{V} \subset \mathfrak{X}(M)$,*
- (iii) *submodules of compactly supported vector fields $\mathcal{V}_c \subset \mathfrak{X}_c(M)$.*

The correspondence between (i) and (ii) is given by

$$\mathcal{V} := \Gamma(M, \mathcal{V}), \quad \Gamma(U, \mathcal{V}) := \{X \in \mathfrak{X}(U) : fX \in \mathcal{V}, \forall f \in C_c^\infty(U)\}.$$

The correspondence between (ii) and (iii) is given by

$$\mathcal{V}_c := \mathcal{V} \cap \mathfrak{X}_c(M), \quad \mathcal{V} := (\mathcal{V}_c)^{\text{loc}}.$$

Furthermore, one has

$$\mathcal{V} \text{ is involutive} \iff \mathcal{V} \text{ is involutive} \iff \mathcal{V}_c \text{ is involutive.}$$

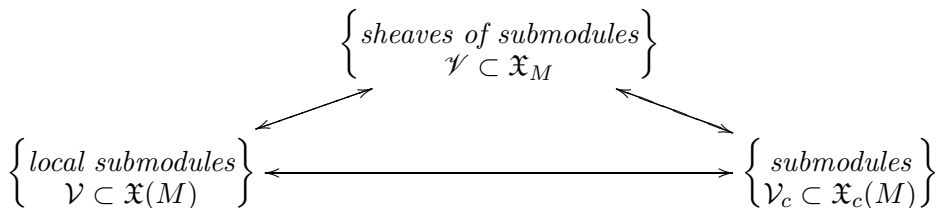

Sheaves are useful to express various local notions. For instance we say that a sheaf of submodules $\mathcal{V} \subset \mathfrak{X}_M$ is **locally finitely generated** if each $x \in M$ has an open neighborhood U and sections $X_1, \dots, X_k \in \Gamma(U, \mathcal{V})$ such that

$$\Gamma_c(U, \mathcal{V}) = C_c^\infty(U) X_1 + \dots + C_c^\infty(U) X_k.$$

Using the correspondences in the previous lemma, one then has notions of locally finitely generated modules of vector fields.

We are now ready to introduce singular foliations.

Definition C.19. A **singular foliation** on a manifold M is a local module of vector fields $\mathcal{V} \subset \mathfrak{X}(M)$ which is both involutive and locally finitely generated. The associated singular **tangent distribution** is defined by

$$T_x \mathcal{V} := \{X_x : X \in \mathcal{V}\} \subset T_x M \quad (x \in M).$$

An **integral submanifold** of \mathcal{V} is a connected immersed submanifold $L \subset M$ with the property that

$$T_x L = T_x \mathcal{V}, \quad \forall x \in L.$$

A **leaf** of \mathcal{V} is a maximal, relative to inclusion, integral submanifold.

We now have the following version of Theorem C.3 for singular foliations:

Theorem C.20. *Given a singular foliation \mathcal{V} on M , each point $x \in M$ belongs to a unique leaf L . Moreover, leaves are initial submanifolds.*

We will not go into the proof here, since this result is not used in the text. For a detailed proof and references to earlier versions, see [10].

Example C.21. For a regular foliation \mathcal{F} on M , the space of vector fields tangent to \mathcal{F}

$$\mathcal{V} := \mathfrak{X}(\mathcal{F})$$

is in particular a singular foliation in the sense of the definition above. Its tangent distribution is $T\mathcal{V} = T\mathcal{F}$ and its leaves coincide with those of \mathcal{F} .

Example C.22. An infinitesimal Lie algebra action $\mathfrak{a} : \mathfrak{g} \rightarrow \mathfrak{X}(M)$ has an associated singular foliation

$$\mathcal{V} := \text{Span}_{C^\infty(M)} \{\mathfrak{a}(v) : v \in \mathfrak{g}\}.$$

The associated tangent distribution is given by

$$T_x \mathcal{V} = \text{Im}(\mathfrak{a}_x : \mathfrak{g} \rightarrow T_x M).$$

The leaves are precisely the orbits of the infinitesimal action.

Example C.23. The main example of interest to us is the singular foliation associated with a Poisson manifold (M, π) . The local submodule $\mathcal{V} \subset \mathfrak{X}(M)$ is the one generated by the Hamiltonian vector fields X_f . Equivalently, it is the image of

$$\pi^\sharp : \Omega^1(M) \rightarrow \mathfrak{X}(M).$$

The associated tangent distributions are the Hamiltonian directions $\text{Im } \pi_x^\sharp$, and the corresponding leaves are the symplectic leaves of (M, π) . This makes precise the term “singular symplectic foliation”, which we sometimes refer to in the book.

Groupoids: Conventions and Choices

In this book we have decided to adopt the following common choices and conventions:

- The Lie bracket of vector fields is the usual commutator of derivations.
- Lie group actions on manifolds are left actions, except for principal bundles where the structure group acts on the right.
- For the Lie algebra of a Lie group we use the bracket arising from left-invariant vector fields.
- Infinitesimal Lie algebra actions are homomorphisms into the Lie algebra of vector fields.
- For Lie algebroids we also use the bracket arising from the Lie bracket of left-invariant vector fields.
- For symplectic groupoids the target is a Poisson map.
- For a groupoid, the composition of two arrows gh is defined whenever $\mathbf{s}(g) = \mathbf{t}(h)$.

We will now explain our choices and conventions and the relationships between them and with other choices.

Lie groups/Lie algebras. Passing from a Lie group G to a Lie algebra \mathfrak{g} can be done using either left- or right-invariant vector fields. Hence, strictly

speaking, any Lie group has two associated Lie brackets and Lie algebras: $(\mathfrak{g}, [\cdot, \cdot]^r)$ and $(\mathfrak{g}, [\cdot, \cdot]^\ell)$. They are defined on the same vector space $\mathfrak{g} = T_e G$ and the difference between the two is only a minus sign. Note that the two notions give rise to the *same* exponential map. On the other hand, all the constructions that are performed using one bracket, say the ℓ -bracket, also have an r -version. For example, a (left) action $G \times M \rightarrow M$ has a corresponding infinitesimal actions (both Lie algebra homomorphisms!):

$$(D.1) \quad \mathfrak{a}^\ell : (\mathfrak{g}, [\cdot, \cdot]^\ell) \rightarrow \mathfrak{X}(M), \quad \mathfrak{a}^\ell(v)_x := \left. \frac{d}{dt} \right|_{t=0} \exp(-tv) \cdot x,$$

$$(D.2) \quad \mathfrak{a}^r : (\mathfrak{g}, [\cdot, \cdot]^r) \rightarrow \mathfrak{X}(M), \quad \mathfrak{a}^r(v)_x := \left. \frac{d}{dt} \right|_{t=0} \exp(tv) \cdot x$$

so that $\mathfrak{a}^r(v) = \mathfrak{a}^\ell(-v)$. In practice, most authors use either the ℓ -version or the r -version of the theory. Often the choice is made so that the induced Lie bracket on $\mathfrak{gl}(V)$ is the commutator: the ℓ -version by authors using our convention for the Lie bracket of vector fields, and the r -version when the anticommutator of derivations is used. The passage from one choice to the other is obvious.

Similar to the previous discussion, some authors prefer left actions while others prefer right actions. In principle, as should be clear by comparing (D.1) and (D.2), it is somewhat more natural to use left actions in combination with the r -bracket, and right actions in combination with the ℓ -bracket. Still, many authors, including ourselves, prefer to focus on left actions, even when using $[\cdot, \cdot]^\ell$. For more details on the consequences of our choices see Appendix A.

Lie groupoids/Lie algebroids. When talking about Lie groupoids $\mathcal{G} \rightrightarrows M$ and their Lie algebroids there is also an ℓ - and an r -facet of the story. The situation is a bit more involved, since there are now two vector bundles

$$A^\ell(\mathcal{G}) = \mathbf{u}^* \text{Ker } dt, \quad A^r(\mathcal{G}) = \mathbf{u}^* \text{Ker } ds.$$

Representing their sections as left/right-invariant vector fields on \mathcal{G} one obtains two brackets and two Lie algebroids

$$(A^\ell(\mathcal{G}), [\cdot, \cdot]^\ell, \rho^\ell), \quad (A^r(\mathcal{G}), [\cdot, \cdot]^r, \rho^r).$$

They are isomorphic via the differential of the inversion map $d\iota$. However, the passage from one to the other becomes more difficult to keep track of, and some notions that coincided for Lie groups become now distinct. For instance, we have now two exponential maps — see Problem 13.14 for \exp^ℓ

— fitting into a commutative diagram

$$\begin{array}{ccc} \Gamma_{\text{cpl}}(A^r(\mathcal{G})) & \xrightarrow{\text{exp}^r} & \Gamma^r(\mathcal{G}) \\ \text{d}\iota \downarrow & & \downarrow \iota \\ \Gamma_{\text{cpl}}(A^\ell(\mathcal{G})) & \xrightarrow{\text{exp}^\ell} & \Gamma^\ell(\mathcal{G}) \end{array}$$

In the literature both brackets are used. An easy trick to navigate between the two conventions in the literature is by replacing a Lie groupoid $\mathcal{G} \rightrightarrows M$ with its opposite groupoid $\mathcal{G}^{\text{op}} \rightrightarrows M$. Here are a few examples. For instance, using $[\cdot, \cdot]^r$, the authors usually make the following choices:

- The homotopy groupoid $\Pi(M) \rightrightarrows M$ of a manifold M is defined as we have done in our book, with $\mathbf{s}[\gamma] = \gamma(0)$ and $\mathbf{t}[\gamma] = \gamma(1)$. In this way the homotopy groupoid acts on M naturally from the *left*.
- The target map $\mathbf{t} : (\Sigma, \Omega) \rightarrow (M, \pi)$ of a symplectic groupoid is a Poisson. In this way, it is the *left* action of Σ on itself that becomes a symplectic groupoid action.

In contrast, using $[\cdot, \cdot]^\ell$, the authors usually choose to do the following:

- Define the homotopy groupoid with $\mathbf{s}[\gamma] = \gamma(1)$ and $\mathbf{t}[\gamma] = \gamma(0)$ and with multiplication defined using the concatenation opposite to how we define it. In this way the natural action on M is from the *right*.
- Require the source map $\mathbf{s} : (\Sigma, \Omega) \rightarrow (M, \pi)$ of a symplectic groupoid to be Poisson. In this way, it is the *right* action of Σ on itself that becomes Hamiltonian.

In general, the works that use $[\cdot, \cdot]^r$ give preference to left actions, while for $[\cdot, \cdot]^\ell$ the preference is for right actions. This is not the case in this book.

The choices in the book. Although the authors of this book have used other conventions before, such as the r -bracket and left actions, here we consider the ℓ -bracket and left actions, as we have already mentioned. For Lie groups the ℓ -bracket seems to be the most common choice in the literature, as explained earlier. For this reason we use it for both Lie groups and Lie groupoids. On the other hand, since our preference is for left actions the following hold:

- We use the initial point $\gamma(0)$ of a path γ to define the source map of the homotopy groupoids $\Pi(M)$, $\Pi(M, \mathcal{F})$, $\Pi(M, \pi)$.
- We require the target map of symplectic groupoids to be Poisson.

How to move to the r -bracket. Let us point out how to write the most relevant formulas of the last chapters using right-invariant vector fields and the r -bracket — while keeping all the other conventions.

- For a left action of \mathcal{G} on $\mu : S \rightarrow M$, the r -version of the infinitesimal action (13.6) is

$$a_p^r : A_x^r(\mathcal{G}) \rightarrow T_p S, \quad a_p^r := d_x \mathcal{R}_p,$$

where (compare with (13.5))

$$\mathcal{R}_p : \mathfrak{s}^{-1}(\mu(p)) \rightarrow S, \quad g \mapsto g \cdot p.$$

- For a symplectic groupoid $(\Sigma, \Omega) \rightrightarrows M$, the induced Lie algebroid isomorphism from Theorem 14.10 has the following r -version:

$$\sigma_\Omega^r : A^r(\Sigma) \rightarrow T^*M, \quad \alpha \mapsto \mathbf{u}^*(i_\alpha \Omega).$$

- The symplectic structure of the cotangent bundle of a Lie groupoid $\mathcal{G} \rightrightarrows M$ from Example 14.24 changes sign:

$$(T^*\mathcal{G}, \omega_{\text{can}}) \rightrightarrows A^r(\mathcal{G})^*.$$

- The formulas (C0) and (C1) in Proposition 14.30 become

$$i_{\vec{\alpha}} \Omega = \mathbf{t}^*(\sigma_\Omega^r(\alpha)), \quad i_{\vec{\alpha}} d\Omega = 0.$$

- In Propositions 14.42 and 14.45, the moment map condition becomes

$$\mu^*(\sigma_\Omega^r(\alpha)) = i_{a^r(\alpha)} \omega.$$

Bibliography

- [1] F. Alcalde-Cuesta and G. Hector, *Intégration symplectique des variétés de Poisson régulières* (French, with English summary), *Israel J. Math.* **90** (1995), no. 1-3, 125–165, DOI 10.1007/BF02783210. MR1336320
- [2] F. Alcalde Cuesta and G. Hector, *Feuilletages en surfaces, cycles évanouissants et variétés de Poisson* (French, with English summary), *Monatsh. Math.* **124** (1997), no. 3, 191–213, DOI 10.1007/BF01298244. MR1476362
- [3] Fernando Alcalde-Cuesta, Pierre Dazord, and Gilbert Hector, *Sur l'intégration symplectique de la structure de Poisson singulière $\Lambda = (x^2 + y^2)\partial/\partial x \wedge \partial/\partial y$ de \mathbf{R}^2* (French, with English summary), *Publ. Mat.* **33** (1989), no. 3, 411–415, DOI 10.5565/PUBLMAT_33389_02. MR1038479
- [4] A. Alekseev and E. Meinrenken, *On the Kashiwara-Vergne conjecture*, *Invent. Math.* **164** (2006), no. 3, 615–634, DOI 10.1007/s00222-005-0486-4. MR2221133
- [5] A. Yu. Alekseev, *On Poisson actions of compact Lie groups on symplectic manifolds*, *J. Differential Geom.* **45** (1997), no. 2, 241–256. MR1449971
- [6] Anton Alekseev, Anton Malkin, and Eckhard Meinrenken, *Lie group valued moment maps*, *J. Differential Geom.* **48** (1998), no. 3, 445–495. MR1638045
- [7] Anton Alekseev and Eckhard Meinrenken, *Linearization of Poisson Lie group structures*, *J. Symplectic Geom.* **14** (2016), no. 1, 227–267, DOI 10.4310/JSG.2016.v14.n1.a9. MR3523256
- [8] Anton Alekseev and Charles Torossian, *The Kashiwara-Vergne conjecture and Drinfeld's associators*, *Ann. of Math. (2)* **175** (2012), no. 2, 415–463, DOI 10.4007/annals.2012.175.2.1. MR2877064
- [9] Rui Almeida and Pierre Molino, *Suites d'Atiyah et feuilletages transversalement complets* (French, with English summary), *C. R. Acad. Sci. Paris Sér. I Math.* **300** (1985), no. 1, 13–15. MR778785
- [10] Iakovos Androulidakis and Georges Skandalis, *The holonomy groupoid of a singular foliation*, *J. Reine Angew. Math.* **626** (2009), 1–37, DOI 10.1515/CRELLE.2009.001. MR2492988
- [11] Camilo Arias Abad and Marius Crainic, *The Weil algebra and the Van Est isomorphism* (English, with English and French summaries), *Ann. Inst. Fourier (Grenoble)* **61** (2011), no. 3, 927–970, DOI 10.5802/aif.2633. MR2918722

- [12] V. I. Arnol'd, *Remarks on Poisson structures on a plane and on other powers of volume elements* (Russian, with English summary), Trudy Sem. Petrovsk. **12** (1987), 37–46, 242, DOI 10.1007/BF01102994; English transl., J. Soviet Math. **47** (1989), no. 3, 2509–2516. MR933050
- [13] Michèle Audin, *Spinning tops: A course on integrable systems*, Cambridge Studies in Advanced Mathematics, vol. 51, Cambridge University Press, Cambridge, 1996. MR1409362
- [14] Mélanie Bertelson, *A h-principle for open relations invariant under foliated isotopies*, J. Symplectic Geom. **1** (2002), no. 2, 369–425. MR1959586
- [15] K. H. Bhaskara and K. Viswanath, *Poisson algebras and Poisson manifolds*, Pitman Research Notes in Mathematics Series, vol. 174, Longman Scientific & Technical, Harlow; copublished in the United States with John Wiley & Sons, Inc., New York, 1988. MR960879
- [16] P. P. Boalch, *Stokes matrices, Poisson Lie groups and Frobenius manifolds*, Invent. Math. **146** (2001), no. 3, 479–506, DOI 10.1007/s002220100170. MR1869848
- [17] Lilian C. Brambila, Pedro Frejlich, and David Martínez Torres, *Coregular submanifolds and poisson submersions*, 2020, arXiv:2010.09058.
- [18] Robert L. Bryant, *Bochner-Kähler metrics*, J. Amer. Math. Soc. **14** (2001), no. 3, 623–715, DOI 10.1090/S0894-0347-01-00366-6. MR1824987
- [19] Jean-Luc Brylinski, *A differential complex for Poisson manifolds*, J. Differential Geom. **28** (1988), no. 1, 93–114. MR950556
- [20] Henrique Bursztyn, *Semiclassical geometry of quantum line bundles and Morita equivalence of star products*, Int. Math. Res. Not. **16** (2002), 821–846, DOI 10.1155/S1073792802108014. MR1891209
- [21] Henrique Bursztyn, *A brief introduction to Dirac manifolds*, Geometric and topological methods for quantum field theory, Cambridge Univ. Press, Cambridge, 2013, pp. 4–38. MR3098084
- [22] Henrique Bursztyn and Alejandro Cabrera, *Multiplicative forms at the infinitesimal level*, Math. Ann. **353** (2012), no. 3, 663–705, DOI 10.1007/s00208-011-0697-5. MR2923945
- [23] Henrique Bursztyn, Alejandro Cabrera, and Cristián Ortiz, *Linear and multiplicative 2-forms*, Lett. Math. Phys. **90** (2009), no. 1-3, 59–83, DOI 10.1007/s11005-009-0349-9. MR2565034
- [24] Henrique Bursztyn and Thiago Drummond, *Lie theory of multiplicative tensors*, Math. Ann. **375** (2019), no. 3-4, 1489–1554, DOI 10.1007/s00208-019-01881-w. MR4023383
- [25] Henrique Bursztyn, Hudson Lima, and Eckhard Meinrenken, *Splitting theorems for Poisson and related structures*, J. Reine Angew. Math. **754** (2019), 281–312, DOI 10.1515/crelle-2017-0014. MR4000576
- [26] Damien Calaque, Tony Pantev, Bertrand Toën, Michel Vaquié, and Gabriele Vezzosi, *Shifted Poisson structures and deformation quantization*, J. Topol. **10** (2017), no. 2, 483–584, DOI 10.1112/topo.12012. MR3653319
- [27] Alberto Candel and Lawrence Conlon, *Foliations. I*, Graduate Studies in Mathematics, vol. 23, American Mathematical Society, Providence, RI, 2000, DOI 10.1090/gsm/023. MR1732868
- [28] Alberto Candel and Lawrence Conlon, *Foliations. II*, Graduate Studies in Mathematics, vol. 60, American Mathematical Society, Providence, RI, 2003, DOI 10.1090/gsm/060. MR1994394
- [29] Ana Cannas da Silva, *Lectures on symplectic geometry*, Lecture Notes in Mathematics, vol. 1764, Springer-Verlag, Berlin, 2001, DOI 10.1007/978-3-540-45330-7. MR1853077
- [30] Ana Cannas da Silva and Alan Weinstein, *Geometric models for noncommutative algebras*, Berkeley Mathematics Lecture Notes, vol. 10, American Mathematical Society, Providence, RI; Berkeley Center for Pure and Applied Mathematics, Berkeley, CA, 1999. MR1747916
- [31] A. S. Cattaneo and M. Zambon, *Coisotropic embeddings in Poisson manifolds*, Trans. Amer. Math. Soc. **361** (2009), no. 7, 3721–3746, DOI 10.1090/S0002-9947-09-04667-4. MR2491897

- [32] Alberto S. Cattaneo and Giovanni Felder, *Poisson sigma models and symplectic groupoids*, Quantization of singular symplectic quotients, Progr. Math., vol. 198, Birkhäuser, Basel, 2001, pp. 61–93. MR1938552
- [33] M. Condevaux, P. Dazord, and P. Molino, *Géométrie du moment* (French), Travaux du Séminaire Sud-Rhodanien de Géométrie, I, Publ. Dép. Math. Nouvelle Sér. B, vol. 88, Univ. Claude-Bernard, Lyon, 1988, pp. 131–160. MR1040871
- [34] Jack F. Conn, *Normal forms for analytic Poisson structures*, Ann. of Math. (2) **119** (1984), no. 3, 577–601, DOI 10.2307/2007086. MR744864
- [35] Jack F. Conn, *Normal forms for smooth Poisson structures*, Ann. of Math. (2) **121** (1985), no. 3, 565–593, DOI 10.2307/1971210. MR794374
- [36] Ivan Contreras and Rui Loja Fernandes, *Genus Integration, Abelianization, and Extended Monodromy*, International Mathematics Research Notices (2019), rnz133.
- [37] A. Coste, P. Dazord, and A. Weinstein, *Groupoïdes symplectiques* (French), Publications du Département de Mathématiques. Nouvelle Série. A, Vol. 2, Publ. Dép. Math. Nouvelle Sér. A, vol. 87, Univ. Claude-Bernard, Lyon, 1987, pp. i–ii, 1–62. MR996653
- [38] Ted Courant and Alan Weinstein, *Beyond Poisson structures*, Action hamiltoniennes de groupes. Troisième théorème de Lie (Lyon, 1986), Travaux en Cours, vol. 27, Hermann, Paris, 1988, pp. 39–49. MR951168
- [39] Theodore James Courant, *Dirac manifolds*, Trans. Amer. Math. Soc. **319** (1990), no. 2, 631–661, DOI 10.2307/2001258. MR998124
- [40] Marius Crainic, *Differentiable and algebroid cohomology, van Est isomorphisms, and characteristic classes*, Comment. Math. Helv. **78** (2003), no. 4, 681–721, DOI 10.1007/s00014-001-0766-9. MR2016690
- [41] Marius Crainic and Rui Loja Fernandes, *Integrability of Lie brackets*, Ann. of Math. (2) **157** (2003), no. 2, 575–620, DOI 10.4007/annals.2003.157.575. MR1973056
- [42] Marius Crainic and Rui Loja Fernandes, *Integrability of Poisson brackets*, J. Differential Geom. **66** (2004), no. 1, 71–137. MR2128714
- [43] Marius Crainic and Rui Loja Fernandes, *Stability of symplectic leaves*, Invent. Math. **180** (2010), no. 3, 481–533, DOI 10.1007/s00222-010-0235-1. MR2609248
- [44] Marius Crainic and Rui Loja Fernandes, *A geometric approach to Conn’s linearization theorem*, Ann. of Math. (2) **173** (2011), no. 2, 1121–1139, DOI 10.4007/annals.2011.173.2.14. MR2776372
- [45] Marius Crainic and Rui Loja Fernandes, *Lectures on integrability of Lie brackets*, Lectures on Poisson geometry, Geom. Topol. Monogr., vol. 17, Geom. Topol. Publ., Coventry, 2011, pp. 1–107, DOI 10.2140/gt. MR2795150
- [46] Marius Crainic, Rui Loja Fernandes, and David Martínez Torres, *Poisson manifolds of compact types (PMCT 1)*, J. Reine Angew. Math. **756** (2019), 101–149, DOI 10.1515/crelle-2017-0006. MR4026450
- [47] Marius Crainic, Rui Loja Fernandes, and David Martínez Torres, *Regular Poisson manifolds of compact types* (English, with English and French summaries), Astérisque **413** (2019), viii + 154, DOI 10.24033/ast. MR4033498
- [48] Marius Crainic and Ioan Mărcuț, *On the existence of symplectic realizations*, J. Symplectic Geom. **9** (2011), no. 4, 435–444. MR2900786
- [49] Marius Crainic and Ioan Mărcuț, *A normal form theorem around symplectic leaves*, J. Differential Geom. **92** (2012), no. 3, 417–461. MR3005059
- [50] I. Cruz and T. Fardilha, *On sufficient and necessary conditions for linearity of the transverse Poisson structure*, J. Geom. Phys. **60** (2010), no. 3, 543–551, DOI 10.1016/j.geomphys.2009.12.001. MR2600014

- [51] P. Dazord and G. Hector, *Intégration symplectique des variétés de Poisson totalement asphériques* (French, with English summary), Symplectic geometry, groupoids, and integrable systems (Berkeley, CA, 1989), Math. Sci. Res. Inst. Publ., vol. 20, Springer, New York, 1991, pp. 37–72, DOI 10.1007/978-1-4613-9719-9_4. MR1104919
- [52] Pierre Dazord, *Groupoïde d'holonomie et géométrie globale* (French, with English and French summaries), C. R. Acad. Sci. Paris Sér. I Math. **324** (1997), no. 1, 77–80, DOI 10.1016/S0764-4442(97)80107-3. MR1435591
- [53] Pierre Dazord and Thomas Delzant, *Le problème général des variables actions-angles* (French), J. Differential Geom. **26** (1987), no. 2, 223–251. MR906389
- [54] Matias del Hoyo and Daniel López Garcia, *On Hausdorff integrations of Lie algebroids*, Monatsh. Math. **194** (2021), no. 4, 811–833, DOI 10.1007/s00605-021-01535-7. MR4228549
- [55] Adrien Douady and Michel Lazard, *Espaces fibrés en algèbres de Lie et en groupes* (French), Invent. Math. **1** (1966), 133–151, DOI 10.1007/BF01389725. MR197622
- [56] V. G. Drinfel'd, *Quantum groups*, Proceedings of the International Congress of Mathematicians, Vol. 1, 2 (Berkeley, Calif., 1986), Amer. Math. Soc., Providence, RI, 1987, pp. 798–820. MR934283
- [57] Pedro Duarte, Rui L. Fernandes, and Waldyr M. Oliva, *Dynamics of the attractor in the Lotka-Volterra equations*, J. Differential Equations **149** (1998), no. 1, 143–189, DOI 10.1006/jdeq.1998.3443. MR1643678
- [58] J.-P. Dufour, *Linéarisation de certaines structures de Poisson* (French, with English summary), J. Differential Geom. **32** (1990), no. 2, 415–428. MR1072912
- [59] Jean-Paul Dufour and Nguyen Tien Zung, *Poisson structures and their normal forms*, Progress in Mathematics, vol. 242, Birkhäuser Verlag, Basel, 2005. MR2178041
- [60] J. J. Duistermaat, *On global action-angle coordinates*, Comm. Pure Appl. Math. **33** (1980), no. 6, 687–706, DOI 10.1002/cpa.3160330602. MR596430
- [61] J. J. Duistermaat and J. A. C. Kolk, *Lie groups*, Universitext, Springer-Verlag, Berlin, 2000, DOI 10.1007/978-3-642-56936-4. MR1738431
- [62] Charles Ehresmann, *Introduction à la théorie des structures infinitésimales et des pseudogroupes de Lie* (French), Colloque de topologie et géométrie différentielle, Strasbourg, 1952, no. 11, La Bibliothèque Nationale et Universitaire de Strasbourg, 1953, pp. 16. MR0061454
- [63] Sam Evens, Jiang-Hua Lu, and Alan Weinstein, *Transverse measures, the modular class and a cohomology pairing for Lie algebroids*, Quart. J. Math. Oxford Ser. (2) **50** (1999), no. 200, 417–436, DOI 10.1093/qjmath/50.200.417. MR1726784
- [64] Rui Loja Fernandes, *A note on poisson symmetric spaces*, Proceedings of the Cornelius Lanczos International Centenary Conference (J. David Brown, Moody T. Chu, Donald C. Ellison, and Robert J. Plemmons, eds.), Society for Industrial and Applied Mathematics (SIAM), Philadelphia, PA, 1994, held at North Carolina State University, Raleigh, North Carolina, December 12–17, 1993, pp. lxvi+644. MR1298212
- [65] Rui Loja Fernandes, *Connections in Poisson geometry. I. Holonomy and invariants*, J. Differential Geom. **54** (2000), no. 2, 303–365. MR1818181
- [66] Rui Loja Fernandes, *Lie algebroids, holonomy and characteristic classes*, Adv. Math. **170** (2002), no. 1, 119–179, DOI 10.1006/aima.2001.2070. MR1929305
- [67] Rui Loja Fernandes and Pedro Frejlich, *An h-principle for symplectic foliations*, Int. Math. Res. Not. IMRN **7** (2012), 1505–1518, DOI 10.1093/imrn/rnr077. MR2913182
- [68] Rui Loja Fernandes and Pol Vanhaecke, *Hyperelliptic Prym varieties and integrable systems*, Comm. Math. Phys. **221** (2001), no. 1, 169–196, DOI 10.1007/s002200100476. MR1846906
- [69] Vladimir V. Fock and Alexander B. Goncharov, *Cluster ensembles, quantization and the dilogarithm* (English, with English and French summaries), Ann. Sci. Éc. Norm. Supér. (4) **42** (2009), no. 6, 865–930, DOI 10.24033/asens.2112. MR2567745

- [70] Philip Foth and Jiang-Hua Lu, *Poisson structures on complex flag manifolds associated with real forms*, Trans. Amer. Math. Soc. **358** (2006), no. 4, 1705–1714, DOI 10.1090/S0002-9947-05-03789-X. MR2186993
- [71] Pedro Frejlich and Ioan Mărcuț, *The normal form theorem around Poisson transversals*, Pacific J. Math. **287** (2017), no. 2, 371–391, DOI 10.2140/pjm.2017.287.371. MR3632892
- [72] Pedro Frejlich and Ioan Mărcuț, *On dual pairs in Dirac geometry*, Math. Z. **289** (2018), no. 1-2, 171–200, DOI 10.1007/s00209-017-1947-3. MR3803786
- [73] Wee Liang Gan and Victor Ginzburg, *Quantization of Slodowy slices*, Int. Math. Res. Not. **5** (2002), 243–255, DOI 10.1155/S107379280210609X. MR1876934
- [74] Michael Gekhtman, Michael Shapiro, and Alek Vainshtein, *Cluster algebras and Poisson geometry*, Mathematical Surveys and Monographs, vol. 167, American Mathematical Society, Providence, RI, 2010, DOI 10.1090/surv/167. MR2683456
- [75] Viktor L. Ginzburg, *Momentum mappings and Poisson cohomology*, Internat. J. Math. **7** (1996), no. 3, 329–358, DOI 10.1142/S0129167X96000207. MR1395934
- [76] Viktor L. Ginzburg, *Equivariant Poisson cohomology and a spectral sequence associated with a moment map*, Internat. J. Math. **10** (1999), no. 8, 977–1010, DOI 10.1142/S0129167X99000422. MR1739368
- [77] Viktor L. Ginzburg, *Grothendieck groups of Poisson vector bundles*, J. Symplectic Geom. **1** (2001), no. 1, 121–169. MR1959580
- [78] Viktor L. Ginzburg and Alex Golubev, *Holonomy on Poisson manifolds and the modular class*, Israel J. Math. **122** (2001), 221–242, DOI 10.1007/BF02809901. MR1826501
- [79] Viktor L. Ginzburg and Jiang-Hua Lu, *Poisson cohomology of Morita-equivalent Poisson manifolds*, Internat. Math. Res. Notices **10** (1992), 199–205, DOI 10.1155/S1073792892000229. MR1191570
- [80] Viktor L. Ginzburg and Alan Weinstein, *Lie-Poisson structure on some Poisson Lie groups*, J. Amer. Math. Soc. **5** (1992), no. 2, 445–453, DOI 10.2307/2152773. MR1126117
- [81] Mark J. Gotay, *On coisotropic imbeddings of presymplectic manifolds*, Proc. Amer. Math. Soc. **84** (1982), no. 1, 111–114, DOI 10.2307/2043821. MR633290
- [82] Ryushi Goto, *Rozansky-Witten invariants of log symplectic manifolds*, Integrable systems, topology, and physics (Tokyo, 2000), Contemp. Math., vol. 309, Amer. Math. Soc., Providence, RI, 2002, pp. 69–84, DOI 10.1090/conm/309/05342. MR1953353
- [83] Marco Gualtieri, *Generalized complex geometry*, Ann. of Math. (2) **174** (2011), no. 1, 75–123, DOI 10.4007/annals.2011.174.1.3. MR2811595
- [84] Victor Guillemin, Eva Miranda, and Ana Rita Pires, *Symplectic and Poisson geometry on b-manifolds*, Adv. Math. **264** (2014), 864–896, DOI 10.1016/j.aim.2014.07.032. MR3250302
- [85] Victor W. Guillemin and Shlomo Sternberg, *Remarks on a paper of Hermann*, Trans. Amer. Math. Soc. **130** (1968), 110–116, DOI 10.2307/1994774. MR217226
- [86] Thomas Hawkins, *Jacobi and the birth of Lie’s theory of groups*, Arch. Hist. Exact Sci. **42** (1991), no. 3, 187–278, DOI 10.1007/BF00375135. MR1124967
- [87] Thomas Hawkins, *Emergence of the theory of Lie groups: An essay in the history of mathematics 1869–1926*, Sources and Studies in the History of Mathematics and Physical Sciences, Springer-Verlag, New York, 2000, DOI 10.1007/978-1-4612-1202-7. MR1771134
- [88] G. Hector, *Une nouvelle obstruction à l’intégrabilité des variétés de Poisson régulières* (French, with English summary), Hokkaido Math. J. **21** (1992), no. 1, 159–185, DOI 10.14492/hokmj/1381413261. MR1153760
- [89] G. Hector, E. Macías, and M. Saralegi, *Lemme de Moser feuilleté et classification des variétés de Poisson régulières* (French, with English summary), Publ. Mat. **33** (1989), no. 3, 423–430, DOI 10.5565/PUBLMAT_33389_04. MR1038481
- [90] Sigurdur Helgason, *Differential geometry, Lie groups, and symmetric spaces*, corrected reprint of the 1978 original, Graduate Studies in Mathematics, vol. 34, American Mathematical Society, Providence, RI, 2001, DOI 10.1090/gsm/034. MR1834454

- [91] Josef Hofbauer and Karl Sigmund, *Evolutionary games and population dynamics*, Cambridge University Press, Cambridge, 1998, DOI 10.1017/CBO9781139173179. MR1635735
- [92] Johannes Huebschmann, *Poisson cohomology and quantization*, J. Reine Angew. Math. **408** (1990), 57–113, DOI 10.1515/crll.1990.408.57. MR1058984
- [93] Vladimir Itskov, Mikhail Karasev, and Yurii Vorobjev, *Infinitesimal Poisson cohomology*, Coherent transform, quantization, and Poisson geometry, Amer. Math. Soc. Transl. Ser. 2, vol. 187, Amer. Math. Soc., Providence, RI, 1998, pp. 327–360, DOI 10.1090/trans2/187/03. MR1728670
- [94] M. V. Karasëv, *Analogues of objects of the theory of Lie groups for nonlinear Poisson brackets* (Russian), Izv. Akad. Nauk SSSR Ser. Mat. **50** (1986), no. 3, 508–538, 638. MR854594
- [95] M. V. Karasëv, *Poisson algebras of symmetries and asymptotic behavior of spectral series* (Russian), Funktsional. Anal. i Prilozhen. **20** (1986), no. 1, 21–32, 96. MR831045
- [96] M. V. Karasev and V. P. Maslov, *Global asymptotic operators of a regular representation* (Russian), Dokl. Akad. Nauk SSSR **257** (1981), no. 1, 33–37. MR608113
- [97] A. A. Kirillov, *Unitary representations of nilpotent Lie groups* (Russian), Uspehi Mat. Nauk **17** (1962), no. 4 (106), 57–110. MR0142001
- [98] A. A. Kirillov, *Local Lie algebras* (Russian), Uspehi Mat. Nauk **31** (1976), no. 4(190), 57–76. MR0438390
- [99] Maxim Kontsevich, *Deformation quantization of Poisson manifolds*, Lett. Math. Phys. **66** (2003), no. 3, 157–216, DOI 10.1023/B:MATH.0000027508.00421.bf. MR2062626
- [100] Leonid I. Korogodski and Yan S. Soibelman, *Algebras of functions on quantum groups. Part I*, Mathematical Surveys and Monographs, vol. 56, American Mathematical Society, Providence, RI, 1998, DOI 10.1090/surv/056. MR1614943
- [101] Yvette Kosmann-Schwarzbach, *La géométrie de Poisson, création du XXe siècle* (French, with French summary), Siméon-Denis Poisson, Hist. Math. Sci. Phys., Ed. Éc. Polytech., Palaiseau, 2013, pp. 129–172. MR3202688
- [102] Yvette Kosmann-Schwarzbach (ed.), *Siméon-Denis Poisson*, Histoire des Mathématiques et des Sciences Physiques. [History of Mathematics and Physics], Éditions de l'École Polytechnique, Palaiseau, 2013, Les mathématiques au service de la science. [Mathematics in the service of science]. MR3183750
- [103] Bertram Kostant, *Orbits, symplectic structures and representation theory*, Proc. U.S.-Japan Seminar in Differential Geometry (Kyoto, 1965), Nippon Hyoronsha, Tokyo, 1966, pp. 71. MR0213476
- [104] Jean-Louis Koszul, *Crochet de Schouten-Nijenhuis et cohomologie* (French), The mathematical heritage of Élie Cartan (Lyon, 1984), Astérisque **Numéro Hors Série** (1985), 257–271. MR837203
- [105] Camille Laurent-Gengoux, Anne Pichereau, and Pol Vanhaecke, *Poisson structures*, Grundlehren der Mathematischen Wissenschaften [Fundamental Principles of Mathematical Sciences], vol. 347, Springer, Heidelberg, 2013, DOI 10.1007/978-3-642-31090-4. MR2906391
- [106] John M. Lee, *Introduction to smooth manifolds*, 2nd ed., Graduate Texts in Mathematics, vol. 218, Springer, New York, 2013. MR2954043
- [107] Songhao Li and Dylan Rupel, *Symplectic groupoids for cluster manifolds*, J. Geom. Phys. **154** (2020), 103688, 32, DOI 10.1016/j.geomphys.2020.103688. MR4099478
- [108] Paulette Libermann, *Problèmes d'équivalence et géométrie symplectique* (French), Third Schnepfenried geometry conference, Vol. 1 (Schnepfenried, 1982), Astérisque, vol. 107, Soc. Math. France, Paris, 1983, pp. 43–68. MR753129
- [109] André Lichnerowicz, *Les variétés de Poisson et leurs algèbres de Lie associées* (French), J. Differential Geometry **12** (1977), no. 2, 253–300. MR501133
- [110] Jiang-Hua Lu, *Momentum mappings and reduction of Poisson actions*, Symplectic geometry, groupoids, and integrable systems (Berkeley, CA, 1989), Math. Sci. Res. Inst. Publ., vol. 20, Springer, New York, 1991, pp. 209–226, DOI 10.1007/978-1-4613-9719-9_15. MR1104930

- [111] Jiang-Hua Lu and Alan Weinstein, *Poisson Lie groups, dressing transformations, and Bruhat decompositions*, J. Differential Geom. **31** (1990), no. 2, 501–526. MR1037412
- [112] Jiang-Hua Lu and Shizhuo Yu, *Bott-Samelson atlases, total positivity, and Poisson structures on some homogeneous spaces*, Selecta Math. (N.S.) **26** (2020), no. 5, Paper No. 70, 61, DOI 10.1007/s00029-020-00595-1. MR4160948
- [113] K. Mackenzie, *Lie groupoids and Lie algebroids in differential geometry*, London Mathematical Society Lecture Note Series, vol. 124, Cambridge University Press, Cambridge, 1987, DOI 10.1017/CBO9780511661839. MR896907
- [114] Kirill C. H. Mackenzie, *General theory of Lie groupoids and Lie algebroids*, London Mathematical Society Lecture Note Series, vol. 213, Cambridge University Press, Cambridge, 2005, DOI 10.1017/CBO9781107325883. MR2157566
- [115] Kirill C. H. Mackenzie and Ping Xu, *Integration of Lie bialgebroids*, Topology **39** (2000), no. 3, 445–467, DOI 10.1016/S0040-9383(98)00069-X. MR1746902
- [116] Charles-Michel Marle, *The inception of symplectic geometry: the works of Lagrange and Poisson during the years 1808–1810*, Lett. Math. Phys. **90** (2009), no. 1-3, 3–21, DOI 10.1007/s11005-009-0347-y. MR2565032
- [117] David Martínez Torres, *A note on the separability of canonical integrations of Lie algebroids*, Math. Res. Lett. **17** (2010), no. 1, 69–75, DOI 10.4310/MRL.2010.v17.n1.a6. MR2592728
- [118] Dusa McDuff and Dietmar Salamon, *Introduction to symplectic topology*, 3rd ed., Oxford Graduate Texts in Mathematics, Oxford University Press, Oxford, 2017, DOI 10.1093/oso/9780198794899.001.0001. MR3674984
- [119] Eckhard Meinrenken, *Poisson geometry from a Dirac perspective*, Lett. Math. Phys. **108** (2018), no. 3, 447–498, DOI 10.1007/s11005-017-0977-4. MR3765970
- [120] Kentaro Mikami and Alan Weinstein, *Moments and reduction for symplectic groupoids*, Publ. Res. Inst. Math. Sci. **24** (1988), no. 1, 121–140, DOI 10.2977/prims/1195175328. MR944869
- [121] Yoshihiko Mitsumatsu, *Leafwise symplectic structures on Lawson’s foliation*, J. Symplectic Geom. **16** (2018), no. 3, 817–838, DOI 10.4310/JSG.2018.v16.n3.a6. MR3882173
- [122] I. Moerdijk and J. Mrčun, *Introduction to foliations and Lie groupoids*, Cambridge Studies in Advanced Mathematics, vol. 91, Cambridge University Press, Cambridge, 2003, DOI 10.1017/CBO9780511615450. MR2012261
- [123] I. Moerdijk and J. Mrčun, *On the universal enveloping algebra of a Lie algebroid*, Proc. Amer. Math. Soc. **138** (2010), no. 9, 3135–3145, DOI 10.1090/S0002-9939-10-10347-5. MR2653938
- [124] Philippe Monnier, *Poisson cohomology in dimension two*, Israel J. Math. **129** (2002), 189–207, DOI 10.1007/BF02773163. MR1910942
- [125] Ioan Mărcuț and Boris Osorno Torres, *Deformations of log-symplectic structures*, J. Lond. Math. Soc. (2) **90** (2014), no. 1, 197–212, DOI 10.1112/jlms/jdu023. MR3245143
- [126] Ryszard Nest and Boris Tsygan, *Deformations of symplectic Lie algebroids, deformations of holomorphic symplectic structures, and index theorems*, Asian J. Math. **5** (2001), no. 4, 599–635, DOI 10.4310/AJM.2001.v5.n4.a2. MR1913813
- [127] Albert Nijenhuis, *Jacobi-type identities for bilinear differential concomitants of certain tensor fields. I, II*, Nederl. Akad. Wetensch. Proc. Ser. A. **58** = Indag. Math. **17** (1955), 390–397, 398–403. MR0074879
- [128] Yong-Geun Oh, *Some remarks on the transverse Poisson structures of coadjoint orbits*, Lett. Math. Phys. **12** (1986), no. 2, 87–91, DOI 10.1007/BF00416457. MR858269
- [129] Richard S. Palais, *A global formulation of the Lie theory of transformation groups*, Mem. Amer. Math. Soc. **22** (1957), iii+123. MR121424
- [130] Tony Pantev, Bertrand Toën, Michel Vaquié, and Gabriele Vezzosi, *Shifted symplectic structures*, Publ. Math. Inst. Hautes Études Sci. **117** (2013), 271–328, DOI 10.1007/s10240-013-0054-1. MR3090262

- [131] Manfred Plank, *Hamiltonian structures for the n -dimensional Lotka-Volterra equations*, J. Math. Phys. **36** (1995), no. 7, 3520–3534, DOI 10.1063/1.530978. MR1339881
- [132] Jean Pradines, *Théorie de Lie pour les groupoïdes différentiables. Relations entre propriétés locales et globales* (French), C. R. Acad. Sci. Paris Sér. A-B **263** (1966), A907–A910. MR214103
- [133] Jean Pradines, *Théorie de Lie pour les groupoïdes différentiables. Calcul différentiel dans la catégorie des groupoïdes infinitésimaux* (French), C. R. Acad. Sci. Paris Sér. A-B **264** (1967), A245–A248. MR216409
- [134] Jean Pradines, *Troisième théorème de Lie les groupoïdes différentiables* (French), C. R. Acad. Sci. Paris Sér. A-B **267** (1968), A21–A23. MR231414
- [135] J. A. Schouten, *On the differential operators of first order in tensor calculus*, Convegno Internazionale di Geometria Differenziale, Italia, 1953, Edizioni Cremonese, Roma, 1954, pp. 1–7. MR0063750
- [136] J.-M. Souriau, *Quantification géométrique* (French, with English summary), Comm. Math. Phys. **1** (1966), 374–398. MR207332
- [137] Michael Spivak, *A comprehensive introduction to differential geometry. Vol. I*, 2nd ed., Publish or Perish, Inc., Wilmington, Del., 1979. MR532830
- [138] Shlomo Sternberg, *Lie algebras*, University Press of Florida, 2009.
- [139] Izu Vaisman, *Remarks on the Lichnerowicz-Poisson cohomology* (English, with French summary), Ann. Inst. Fourier (Grenoble) **40** (1990), no. 4, 951–963 (1991). MR1096599
- [140] Izu Vaisman, *On the geometric quantization of Poisson manifolds*, J. Math. Phys. **32** (1991), no. 12, 3339–3345, DOI 10.1063/1.529446. MR1137387
- [141] Izu Vaisman, *Lectures on the geometry of Poisson manifolds*, Progress in Mathematics, vol. 118, Birkhäuser Verlag, Basel, 1994, DOI 10.1007/978-3-0348-8495-2. MR1269545
- [142] W. T. van Est, *Une démonstration de É. Cartan du troisième théorème de Lie* (French), Action hamiltoniennes de groupes. Troisième théorème de Lie (Lyon, 1986), Travaux en Cours, vol. 27, Hermann, Paris, 1988, pp. 83–96. MR951172
- [143] Yu. M. Vorob'ev and M. V. Karasëv, *Poisson manifolds and the Schouten bracket* (Russian), Funktsional. Anal. i Prilozhen. **22** (1988), no. 1, 1–11, 96, DOI 10.1007/BF01077717; English transl., Funct. Appl. **22** (1988), no. 1, 1–9. MR936694
- [144] Yu. M. Vorob'ev and M. V. Karasëv, *Deformation and cohomologies of Poisson brackets [in Topological and geometric methods of analysis (Russian), 75–89, Voronezh. Gos. Univ., Voronezh, 1989; MR1047671 (91g:58098)]*, Global analysis—studies and applications, IV, Lecture Notes in Math., vol. 1453, Springer, Berlin, 1990, pp. 271–289, DOI 10.1007/BFb0085961. MR1096519
- [145] Pavol Ševera, *Some title containing the words “homotopy” and “symplectic”, e.g. this one*, Travaux mathématiques. Fasc. XVI, Trav. Math., vol. 16, Univ. Luxemb., Luxembourg, 2005, pp. 121–137. MR2223155
- [146] Frank W. Warner, *Foundations of differentiable manifolds and Lie groups*, Scott, Foresman and Co., Glenview, Ill.-London, 1971. MR0295244
- [147] Alan Weinstein, *The local structure of Poisson manifolds*, J. Differential Geom. **18** (1983), no. 3, 523–557. MR723816
- [148] Alan Weinstein, *Errata and addenda: “The local structure of Poisson manifolds” [J. Differential Geom. **18** (1983), no. 3, 523–557; MR0723816 (86i:58059)]*, J. Differential Geom. **22** (1985), no. 2, 255. MR834280
- [149] Alan Weinstein, *Poisson structures and Lie algebras*, The mathematical heritage of Élie Cartan (Lyon, 1984), Astérisque, Hors Série, Société Mathématique de France, Paris, 1985, pp. 421–434. MR837210
- [150] Alan Weinstein, *Poisson geometry of the principal series and nonlinearizable structures*, J. Differential Geom. **25** (1987), no. 1, 55–73. MR873455

- [151] Alan Weinstein, *Symplectic groupoids and Poisson manifolds*, Bull. Amer. Math. Soc. (N.S.) **16** (1987), no. 1, 101–104, DOI 10.1090/S0273-0979-1987-15473-5. MR866024
- [152] Alan Weinstein, *Coisotropic calculus and Poisson groupoids*, J. Math. Soc. Japan **40** (1988), no. 4, 705–727, DOI 10.2969/jmsj/04040705. MR959095
- [153] Alan Weinstein, *Blowing up realizations of Heisenberg-Poisson manifolds* (English, with French summary), Bull. Sci. Math. **113** (1989), no. 4, 381–406. MR1029617
- [154] Alan Weinstein, *Noncommutative geometry and geometric quantization*, Symplectic geometry and mathematical physics (Aix-en-Provence, 1990), Progr. Math., vol. 99, Birkhäuser Boston, Boston, MA, 1991, pp. 446–461. MR1156554
- [155] Alan Weinstein, *The modular automorphism group of a Poisson manifold*, J. Geom. Phys. **23** (1997), no. 3-4, 379–394, DOI 10.1016/S0393-0440(97)80011-3. MR1484598
- [156] Alan Weinstein, *Poisson geometry: Symplectic geometry*, Differential Geom. Appl. **9** (1998), no. 1-2, 213–238, DOI 10.1016/S0926-2245(98)00022-9. MR1636305
- [157] Alan Weinstein and Ping Xu, *Extensions of symplectic groupoids and quantization*, J. Reine Angew. Math. **417** (1991), 159–189. MR1103911
- [158] Ping Xu, *Morita equivalence of Poisson manifolds*, Comm. Math. Phys. **142** (1991), no. 3, 493–509. MR1138048
- [159] Ping Xu, *Morita equivalence and symplectic realizations of Poisson manifolds*, Ann. Sci. École Norm. Sup. (4) **25** (1992), no. 3, 307–333. MR1169134
- [160] Ping Xu, *Poisson cohomology of regular Poisson manifolds* (English, with English and French summaries), Ann. Inst. Fourier (Grenoble) **42** (1992), no. 4, 967–988. MR1196101
- [161] Ping Xu, *Dirac submanifolds and Poisson involutions* (English, with English and French summaries), Ann. Sci. École Norm. Sup. (4) **36** (2003), no. 3, 403–430, DOI 10.1016/S0012-9593(03)00013-2. MR1977824
- [162] S. Zakrzewski, *Quantum and classical pseudogroups. I. Union pseudogroups and their quantization*, Comm. Math. Phys. **134** (1990), no. 2, 347–370. MR1081010

Index

- A-connection, 274, 295
 - nonlinear, 294, 301
- A-differential, 207
- A-form, 207
- A-path, 249, 294, 301, 346
- A-path homotopy, 249, 301, 346
- action-angle coordinates, 307
- action Lie algebroid, 199, 332
- action Lie groupoid, 318
- adjoint action, 430
- adjoint representation, 430
- affine Poisson structure, 37, 116
- almost Dirac structure, 138
- anchor map, 197
- anti-Poisson involution, 180
- Atiyah algebroid, 336

- backward Dirac map, 141
- basic form, 433, 453
- biderivation, 25
- bisection, 359
- bivector field, 23
 - decomposable, 31
 - nondegenerate, 32
 - Poisson, 26
 - rank, 43
- bundle of Lie algebras, 331
- bundle of Lie groups, 317

- Cartan's magic formula, 436
- Casimir function, 6, 201
- chart
 - Darboux, 439
 - foliated, 447
 - Weinstein splitting, 44
- Chevalley-Eilenberg complex, 427
- Christoffel symbols, 253, 267
- coadjoint action, 432
- coadjoint orbits, 37, 432, 441
- coadjoint representation, 432
- cohomology
 - foliated, 208, 452
 - Lie algebra, 208, 427
 - Lie algebroid, 208
 - Poisson, 200
 - compactly supported, 219
- coisotropic embedding, 178
- coisotropic reduction, 176
- coisotropic submanifold, 172, 173, 198
 - characteristic distribution of, 176
 - characteristic foliation of, 176
- compact Lie algebra, 54, 162
- compactly supported
 - time-dependent vector field, 434
- compactly supported Poisson
 - cohomology, 219
- complete
 - infinitesimal action, 429
 - Poisson map, 309
 - Poisson submanifold, 160
 - section, 328, 360
 - symplectic realization, 326, 368
 - time-dependent vector field, 434
- completely integrable 1-form, 34, 41, 449
- concatenation, 225

- Conn's Linearization Theorem, 54
 conormal space, 52
 constant Poisson structure, 11, 36, 106, 374
 contravariant
 derivative, 257
 parallel transport, 260
 Stokes's Theorem, 231
 vector bundle, 253
 contravariant connection, 253, 265, 395
 Bott, 255, 262
 characteristic class, 256
 Christoffel symbols, 253, 267
 curvature, 254
 dual, 266
 flat, 254, 260
 geodesic, 266
 nonlinear, 295
 on a Poisson manifold, 265
 on a vector bundle, 253
 parallel transport, 260
 torsion, 265
 torsion-free, 267
 coregular Poisson-Dirac submanifold, 169
 cosymplectic structure, 71
 cosymplectic submanifold, 86
 cotangent
 homologous, 242
 homotopy, 228
 loop, 242
 map, 226
 path, 223
 path-homotopy, 234
 cotangent Lie algebroid, 198, 339
 cotangent Lie groupoid, 344
 cotangent map, 226
 boundary of, 227
 integral along, 230
 restriction to submanifold, 227
 cotangent path, 84
 integral along, 229
 lift, 293
 parallel transport along, 260, 299
 reparameterization, 224
 reversed, 225
 coupling construction, 76, 79, 151
 Courant bracket, 153
 cover groupoid, 321
 curl operator, 220
 Darboux chart, 439
 Darboux's Theorem, 439
 derivation
 of a vector bundle, 333
 symbol of, 333
 Dirac bracket, 90
 Dirac manifold, 138
 presymplectic leaf of, 141
 Dirac map
 backward, 141
 forward, 141
 Dirac structure, 138
 Φ -invariant, 145
 almost, 138
 constant, 134
 diffeomorphism of, 142
 gauge equivalent, 150
 gauge transform, 136, 150
 kernel, 135
 Poisson support, 140
 pullback, 136, 142
 pushforward, 136, 145
 quotient, 147
 range, 135
 regular, 141
 twisted, 156
 distribution
 involutive, 448
 regular, 448
 singular, 456
 Dorfman bracket, 137, 199
 dual of a Lie algebroid, 339, 376
 dual pair, 119, 405
 Ehresmann connection, 290
 complete, 290
 flat, 290
 Euler vector field, 213
 exponential map
 Lie groupoid, 360
 fiberwise linear multivector field, 340
 flow of a section, 222
 foliated chart, 447
 foliated cohomology, 452
 Foliated Darboux Theorem, 453
 foliated form, 452
 closed, 452
 nondegenerate, 452
 symplectic, 33, 69, 453
 foliation, 447
 chart, 447, 449
 codimension 1, 449

- holonomy, 325
- holonomy groupoid of, 325
- homotopy groupoid of, 324
- leaf, 447, 456
- linear, 77
- modular class, 218
- plaque, 449
- Reeb, 70
- regular, 198, 447
- simple, 119, 148, 449
- singular, 29, 454, 456
- symplectic (regular), 33, 69, 453
- form
 - basic, 433, 453
 - foliated, 453
 - horizontal, 433
 - invariant, 433
 - left-invariant (on a Lie group), 427
 - left-invariant (on a Lie groupoid), 329
 - Maurer-Cartan, 114, 428
 - multiplicative, 362
 - multiplicative symplectic, 363
 - multiplicatively exact, 362
 - on a Lie algebroid, 207
 - presymplectic, 141
 - rank, 437
 - right-invariant (on a Lie group), 427
 - right-invariant (on a Lie groupoid), 329
 - symplectic, 437
 - transversely symplectic, 453
- forward Dirac map, 141
- frame bundle, 322
- Frobenius Theorem
 - global version, 448
 - local version, 449
- function group, 103, 112
- fundamental class, 204
- gauge groupoid, 319
- gauge transform, 137
- gauge transformation
 - of Dirac structure, 136, 150
 - of generalized tangent bundle, 149
 - of Poisson structure, 93, 150
 - of symplectic realization, 151
- general Lie algebroid, 333
- general Lie groupoid, 322
- generalized differential, 142
- generalized tangent bundle, 134, 137
 - automorphism of, 149
 - gauge transformation, 149
- geodesic, 266
 - flow, 267, 395
 - spray, 267
- Gotay's Theorem, 179
- group of spherical periods, 338
- groupoid, 313
 - action, 292
 - inverse map, 313
 - Lie, 314
 - multiplication, 313
 - transitive, 319
 - unit map, 313
- Hamiltonian action, 17, 18, 162, 443
 - moment map of, 17, 18, 443
- Hamiltonian diffeomorphism, 7
- Hamiltonian group, 7
- Hamiltonian isotopy, 7
- Hamiltonian space, 10, 17, 74, 112, 122, 287, 443
 - symplectic groupoid, 388
 - weak, 116
- Hamiltonian vector field, 3, 29, 202, 437
- Hausdorff integrable, 352
- holonomy
 - foliation, 325
 - groupoid, 325
- homotopy groupoid, 292
 - of a foliation, 324
 - of a Lie algebroid, 346
 - of a manifold, 292, 317
 - of a Poisson manifold, 301, 326
- horizontal form, 433
- Hurewicz homomorphism, 243
- identity groupoid, 317
- infinitesimal action
 - of a Lie algebra, 429
 - of a Lie algebroid, 301
 - symplectic, 442
- initial submanifold, 450
- integrability problem, 377, 395
- integrable lattice, 105, 303
- integrable Poisson manifold, 377
- integrable system, 10
- integral affine chart, 306
- integral affine structure, 306
 - transverse, 311
- integration of Lie algebroid, 328, 352
- invariant form, 433
- invariant volume form, 202, 203
- isotropy group

- of a groupoid, 315
- isotropy Lie algebra, 50
 - of a Lie algebroid, 330
 - of a Poisson manifold, 50
 - of an infinitesimal action, 430
- Jacobi identity, 425
- Kirillov-Kostant-Souriau symplectic form, 74
- Lagrangian fibration, 302
- Lagrangian submanifold, 172
- lattice, 104, 303
 - integrable, 105, 303
- leaf of a foliation, 447, 456
- leaf space (of a Poisson manifold), 91
- Leibniz identity, 197
- Libermann's Theorem, 118, 147, 355
- Lie algebra, 425
 - action, 429
 - adjoint, 430
 - coadjoint, 432
 - linear, 430
 - orbit, 435
 - symplectic, 442
 - central extension, 40
 - cocycle, 38
 - cohomology, 427
 - cohomology with coefficients, 428
 - compact, 54, 162
 - complete action, 429
 - homomorphism, 426
 - isotropy, 430
 - representation, 428, 431
 - adjoint, 430
 - coadjoint, 432
 - semisimple, 54, 428
 - structure constants, 425
 - unimodular, 203
- Lie algebroid, 28, 197, 326
 - action, 284, 301, 332
 - integrable, 333
 - integration of, 333
 - central extension, 337
 - cohomology, 208
 - complete section, 328, 360
 - differential, 207
 - dual, 339, 376
 - flow of a section, 222
 - form, 207
 - integrable, 328, 352
 - integration of, 328, 352
 - isotropy Lie algebra, 330
 - morphism, 211
 - integration of, 330
 - of a Dirac structure, 199
 - of a foliation, 198
 - of a Lie groupoid, 327
 - of a Poisson structure, 198, 339
 - of an infinitesimal action, 199
 - orbit, 338
 - pullback along map, 335
 - regular, 331
 - representation, 359
 - singular foliation of, 199
 - subalgebroid, 330
 - transitive, 212, 337
- Lie algebroid action, 332
- Lie bracket, 425
- Lie derivative
 - along time-dependent vector field, 435
 - of multivector field, 27
- Lie group, 316, 425
 - action, 428
 - adjoint, 430
 - coadjoint, 432
 - free, 432
 - Hamiltonian, 17, 18, 162, 443
 - isotropy group, 428
 - linear, 430
 - locally free, 432
 - orbit, 428, 450
 - Poisson, 17, 183
 - proper, 432
 - symplectic, 441
 - homomorphism, 426
 - representation, 431
 - adjoint, 430
 - coadjoint, 432
- Lie groupoid, 314
 - action, 323
 - bisection, 359
 - connected component of the identity, 358
 - exponential map, 360
 - isotropy group, 315
 - left translation, 314
 - morphism, 315
 - multiplicative form, 362
 - multiplicative symplectic form, 363
 - multiplicatively exact form, 362

- non-Hausdorff, 352
- orbit, 315
- pullback along map, 320
- representation, 358
- restriction to submanifold, 320
- right translation, 314
- s -fiber, 314
- subgroupoid, 316
- symplectic, 363
- t -fiber, 314
- transitive, 319
- Lie's function group, 103, 112
- Lie's Theorems, 345
 - Lie algebras, 346, 427
 - Lie algebroids, 345, 346, 348, 351
- linear approximation
 - to Poisson structure, 51
 - transverse, 52
- linear foliation, 77
- linear Poisson holonomy, 262, 264
- linear Poisson structure, 11, 36, 74, 111, 208, 286, 369, 375
 - Slodowy slice, 97
- linear vector field, 431
- linearizable Poisson structure, 53
- Liouville 1-form, 440
- Liouville volume form, 439
- Local Splitting Theorem, 44
- local symplectic realization, 125
- log-symplectic Poisson structure, 49, 73, 203, 210
 - singular locus of, 49
- LV-type Poisson structure, 14, 107, 371, 375
- Maurer-Cartan form, 114, 428
- modular class
 - of a foliation, 218
 - of a Poisson manifold, 256
 - of a Poisson structure, 203
- modular vector field, 202
- moduli space of Poisson structures, 206
- moment map, 17, 18, 443
 - symplectic groupoid action, 388
- monodromy group, 411
- monodromy map, 347, 411
- Morita equivalence, 405
- morphism of Lie algebroids, 211
- morphism of Lie groupoids, 315
- Moser's Lemma
 - for Poisson structures, 94, 214
 - for symplectic structures, 440
- multiderivation, 25
- multiplicative form, 362
 - exact, 362
 - symplectic, 363
- multivector field, 23
 - Φ -related, 30
 - fiberwise linear, 340
 - integral along cotangent map, 230
 - interior product, 42
 - Lie derivative, 27
 - local representation, 24
 - pushforward, 30
 - wedge product, 24
- Nijenhuis torsion, 357
- nondegenerate Poisson structure, 373
- nonlinear A -connection, 294, 301
- normal space, 52
- Novikov's Theorem, 71
- orbit
 - of a Lie algebra action, 435
 - of a Lie algebroid, 338
 - of a Lie group action, 450
 - of a Lie groupoid, 315
 - of a Poisson manifold, 5, 63, 67
- orbit foliation, 284
 - of a Lie algebra action, 435
 - of a Lie algebroid, 338
 - of a Lie group action, 450
 - of a Lie groupoid, 315
- π -orthogonal, 86, 157
- pair groupoid, 317
- parallel curve, 259
- parallel transport, 260, 299
 - along A -connection, 274
 - along nonlinear A -connection, 294, 301
- plaque, 449
- Poisson action, 17, 183
- Poisson bivector, 26
- Poisson bracket, 3
 - Jacobi identity, 3, 5
 - Leibniz identity, 3
 - of symplectic manifold, 438
 - structure functions, 4
- Poisson cohomology, 42, 200
 - compactly supported, 219
 - fundamental class, 204
 - linearization class, 216
 - Mayer-Vietoris sequence, 218

- modular class, 203, 256
- relative to a leaf, 212
- restricted to a leaf, 212
- Poisson diffeomorphism, 6
 - affine, 38
- Poisson differential, 200
- Poisson homology, 219
- Poisson homology group, 242
- Poisson homotopy cover, 80, 326
- Poisson homotopy group, 237
- Poisson homotopy groupoid, 301, 326, 395
- Poisson involution, 180
- Poisson manifold, 3, 26
 - cotangent Lie algebroid of, 198, 339
 - exact, 204
 - fundamental class of, 204
 - integrable, 377
 - leaf space, 91
 - linear model around leaf, 79
 - linearization class of, 216
 - modular class, 203
 - modular class of, 256
 - nonintegrable, 411, 412
 - orbit of, 5, 63, 67
 - symplectic foliation of, 63, 67, 69
 - symplectic integration, 377, 378
 - symplectic leaf of, 6, 63
 - unimodular, 203
- Poisson map, 3
 - complete, 283, 309
- Poisson relation, 190
- Poisson structure, 26
 - 2-dimensional, 47
 - affine, 37, 116
 - canonical, 9
 - constant, 11, 36, 106, 374
 - family, 33, 39
 - gauge equivalent, 93, 150
 - gauge transform, 93, 150
 - isotropy Lie algebra, 50
 - Jacobi identity, 26, 28
 - Leibniz identity, 28
 - linear, 11, 36, 74, 111, 208, 286, 369, 375
 - linear approximation, 51
 - linearizable, 53
 - log-symplectic, 49, 73, 203, 210
 - singular locus, 49
 - LV-type, 14, 107, 371, 375
 - moduli space of, 206
 - nondegenerate, 32, 290, 373
 - quadratic, 13, 109, 373
 - quotient, 14, 17, 147, 376
 - rank, 43
 - regular, 69, 209, 235
 - regular point of, 46
 - singular point, 47
 - structure functions, 4
 - transverse, 94
 - transverse linear approximation, 52
 - zero, 10, 104, 235, 288, 374
- Poisson submanifold, 157
 - complete, 160
 - embedded, 157
 - immersed, 157
- Poisson support (of Dirac structure), 140
- Poisson transversal, 86
- Poisson vector field, 7, 27, 202
- Poisson-Dirac submanifold, 165
 - coregular, 169
- Poisson-Lie group, 19
- polyvector field, 23
- pre-Poisson reduction, 187
- pre-Poisson submanifold, 184
 - characteristic foliation of, 187
- prequantization bundle, 338
- prequantization Lie algebroid, 337
- presymplectic form, 141
- presymplectic leaf, 141
- pullback Dirac structure, 136, 142
- pullback Lie algebroid, 336
- pullback Lie groupoid, 321
- pushforward Dirac structure, 136, 145

- quadratic Poisson structure, 13, 109, 373
- quotient Dirac structure, 147
- quotient Poisson structure, 14, 17, 147, 376

- reduction
 - Dirac, 147
 - symplectic, 148, 444
- Reeb foliation, 70
- Reeb Stability Theorem, 77
- Reeb vector field, 71
- regular Dirac structure, 141
- regular foliation, 198, 447
 - symplectic, 33, 41, 69
- regular Lie algebroid, 331
- regular point, 46

- regular Poisson structure, 69, 209, 235
- relative Poisson cohomology, 212
- reparameterization, 224
- restricted Poisson cohomology, 212
- Riemannian integrable, 352

- Schouten bracket, 25, 26, 220
- semisimple Lie algebra, 54, 428
- sheaf of vector fields, 455
- singular foliation, 454, 456
- singular point, 47
- slice (to symplectic leaf), 85
- Slodowy slice, 97
- source map, 313
- splitting chart, 44
- Stokes's Theorem, 231
- structure equations, 111, 112
- structure functions, 4
- submanifold
 - coisotropic, 172
 - cosymplectic, 86
 - Poisson, 157
 - Poisson submanifold
 - complete, 160
 - Poisson transversal, 86
 - Poisson-Dirac, 165
 - coregular, 169
 - pre-Poisson, 184
- submersion groupoid, 317
- submodule of vector fields, 454
 - compactly supported, 454
 - involutive, 454
 - local, 454
 - localization, 455
- symbol of derivation, 333
- symbols, list of, xvii
- symplectic action, 441
- symplectic foliation
 - of a Poisson manifold, 63, 67, 69
 - regular, 33, 41, 69, 453
- symplectic form, 437
- symplectic groupoid, 363
 - action, 388
- symplectic integration, 377, 378, 395
- symplectic leaf, 6, 63, 67
 - conormal space, 52
 - normal space, 52
- symplectic manifold, 437
 - exact, 444
- symplectic map, 10, 437
- symplectic quotient, 148, 444
- symplectic realization, 101, 269, 270
 - complete, 128, 283, 326, 368
 - infinitesimal action, 284
 - local, 125
 - proper, 128
- symplectic realizations
 - non-Hausdorff, 356
- symplectic reduction, 148, 444
- symplectic structure, 9, 32, 437
- symplectic vector field, 438
- symplectomorphism, 437

- tangent Lie algebroid, 334
- tangent Lie groupoid, 321
- target map, 313
- torsion, 265
- transitive Lie algebroid, 212, 337
- transitive Lie groupoid, 319
- transverse integral affine structure, 311
- transverse Poisson structure, 94
- transversely symplectic form, 453
- twisted Dirac structure, 156

- variation of symplectic area, 246, 249, 411
- vector field
 - Euler, 213
 - Euler-like, 214
 - flow, 318, 433
 - Hamiltonian, 3, 29, 202, 437
 - integral along cotangent path, 229
 - Lie derivative, 435
 - modular, 202
 - Poisson, 7, 27, 202
 - Reeb, 71
 - right/left invariant (in a groupoid), 327
 - symplectic, 438
 - time-dependent, 433, 434
 - compactly supported, 434
 - complete, 434
- vertical foliation, 284

- weak Hamiltonian space, 116
- Weinstein groupoid, 346
- Weinstein splitting chart, 44
- Weinstein Splitting Theorem, 44
- Whitehead's Lemma, 428

- zero of Poisson structure, 51
 - linear approximation at, 51
- zero Poisson structure, 10, 104, 235, 288, 374

Selected Published Titles in This Series

- 217 **Marius Crainic, Rui Loja Fernandes, and Ioan Mărcuț**, Lectures on Poisson Geometry, 2021
- 211 **Mateusz Michałek and Bernd Sturmfels**, Invitation to Nonlinear Algebra, 2021
- 210 **Bruce E. Sagan**, Combinatorics: The Art of Counting, 2020
- 209 **Jessica S. Purcell**, Hyperbolic Knot Theory, 2020
- 208 **Vicente Muñoz, Ángel González-Prieto, and Juan Ángel Rojo**, Geometry and Topology of Manifolds, 2020
- 207 **Dmitry N. Kozlov**, Organized Collapse: An Introduction to Discrete Morse Theory, 2020
- 206 **Ben Andrews, Bennett Chow, Christine Guenther, and Mat Langford**, Extrinsic Geometric Flows, 2020
- 205 **Mikhail Shubin**, Invitation to Partial Differential Equations, 2020
- 204 **Sarah J. Witherspoon**, Hochschild Cohomology for Algebras, 2019
- 203 **Dimitris Koukoulopoulos**, The Distribution of Prime Numbers, 2019
- 202 **Michael E. Taylor**, Introduction to Complex Analysis, 2019
- 201 **Dan A. Lee**, Geometric Relativity, 2019
- 200 **Semyon Dyatlov and Maciej Zworski**, Mathematical Theory of Scattering Resonances, 2019
- 199 **Weinan E, Tiejun Li, and Eric Vanden-Eijnden**, Applied Stochastic Analysis, 2019
- 198 **Robert L. Benedetto**, Dynamics in One Non-Archimedean Variable, 2019
- 197 **Walter Craig**, A Course on Partial Differential Equations, 2018
- 196 **Martin Stynes and David Stynes**, Convection-Diffusion Problems, 2018
- 195 **Matthias Beck and Raman Sanyal**, Combinatorial Reciprocity Theorems, 2018
- 194 **Seth Sullivant**, Algebraic Statistics, 2018
- 193 **Martin Lorenz**, A Tour of Representation Theory, 2018
- 192 **Tai-Peng Tsai**, Lectures on Navier-Stokes Equations, 2018
- 191 **Theo Bühler and Dietmar A. Salamon**, Functional Analysis, 2018
- 190 **Xiang-dong Hou**, Lectures on Finite Fields, 2018
- 189 **I. Martin Isaacs**, Characters of Solvable Groups, 2018
- 188 **Steven Dale Cutkosky**, Introduction to Algebraic Geometry, 2018
- 187 **John Douglas Moore**, Introduction to Global Analysis, 2017
- 186 **Bjorn Poonen**, Rational Points on Varieties, 2017
- 185 **Douglas J. LaFountain and William W. Menasco**, Braid Foliations in Low-Dimensional Topology, 2017
- 184 **Harm Derksen and Jerzy Weyman**, An Introduction to Quiver Representations, 2017
- 183 **Timothy J. Ford**, Separable Algebras, 2017
- 182 **Guido Schneider and Hannes Uecker**, Nonlinear PDEs, 2017
- 181 **Giovanni Leoni**, A First Course in Sobolev Spaces, Second Edition, 2017
- 180 **Joseph J. Rotman**, Advanced Modern Algebra: Third Edition, Part 2, 2017
- 179 **Henri Cohen and Fredrik Strömberg**, Modular Forms, 2017
- 178 **Jeanne N. Clelland**, From Frenet to Cartan: The Method of Moving Frames, 2017
- 177 **Jacques Sauloy**, Differential Galois Theory through Riemann-Hilbert Correspondence, 2016
- 176 **Adam Clay and Dale Rolfson**, Ordered Groups and Topology, 2016
- 175 **Thomas A. Ivey and Joseph M. Landsberg**, Cartan for Beginners: Differential Geometry via Moving Frames and Exterior Differential Systems, Second Edition, 2016
- 174 **Alexander Kirillov Jr.**, Quiver Representations and Quiver Varieties, 2016

For a complete list of titles in this series, visit the
AMS Bookstore at www.ams.org/bookstore/gsmseries/.