

SYMMETRY AND RESONANCE IN HAMILTONIAN SYSTEMS*

J. M. TUWANKOTTA^{†‡} AND F. VERHULST[†]

Abstract. In this paper we study resonances in two degrees of freedom, autonomous, Hamiltonian systems. Due to the presence of a symmetry condition on one of the degrees of freedom, we show that some of the resonances vanish as lower order resonances. After giving a sharp estimate of the resonance domain, we investigate this order change of resonance in a rather general potential problem with discrete symmetry and consider as an example the Hénon–Heiles family of Hamiltonians. We also study a classical example of a mechanical system with symmetry, the elastic pendulum, which leads to a natural hierarchy of resonances with the 4 : 1-resonance as the most prominent after the 2 : 1-resonance and which explains why the 3 : 1-resonance is neglected.

Key words. Hamiltonian mechanics, higher order resonance, normal forms, symmetry, elastic pendulum

AMS subject classifications. 34E05, 70H33, 70K30

PII. S0036139900365323

1. Introduction. Symmetries play an essential part in studying the theory and applications of dynamical systems. In the old literature, attention was usually paid to the relation between symmetry and the existence of first integrals, but recently the relation between symmetry and resonance, in particular its influence on normal forms, has been explored using equivariant bifurcation and singularity theory; see Golubitsky and Stewart [11], Golubitsky, Stewart, and Schaeffer [10], or Broer et al. [5] and also [29] for references. For a general dynamical systems reference see [1, 6]; for symmetry in the context of Hamiltonian systems; see [6, 15, 28].

In the literature the emphasis is usually on the low order resonances like 1 : 2 or 1 : 1 for the obvious reason that in these cases there is interesting dynamics while the number of nonlinear terms to be retained in the analysis is minimal. This emphasis is also found in applications; see Nayfeh and Mook [16] for examples of mechanical engineering. Since in practice higher order resonance will occur more often than the low order case we shall focus here on the theory and application of higher order resonance, extending [21, 22].

In our analysis we shall use normal forms where in the usual way a small parameter ε is introduced by rescaling the variables; see section 2. The implication is that, as ε is small we analyze the dynamics of the Hamiltonian flow in the neighborhood of equilibrium corresponding with the origin of phase space. Note that ε^2 is a measure for the energy with respect to equilibrium. Putting $\varepsilon = 0$, the equations of motion reduce to linear decoupled oscillators.

Apart from considering frequency ratios one can also classify resonance in the sense of energy interchange between the degrees of freedom. Terms like strong (or genuine) resonance and weak resonance are used to express the order of energy inter-

*Received by the editors January 13, 2000; accepted for publication (in revised form) July 31, 2000; published electronically December 13, 2000. The research of the first author was supported by the Mathematisch Instituut, Universiteit Utrecht, The Netherlands and CICAT TUDelft.

<http://www.siam.org/journals/siap/61-4/36532.html>

[†]Mathematisch Instituut, PO Box 80.010, 3508 TA Utrecht, The Netherlands (tuwankotta@math.uu.nl, verhulst@math.uu.nl).

[‡]On leave from Jurusan Matematika, FMIPA, Institut Teknologi Bandung, Ganesha no. 10, Bandung, Indonesia.

change on a certain time-scale which is characteristic for the dynamics of the system; see the discussion in section 6.

Symmetries arise naturally in applications—think, for instance, of the plane of symmetry of a pendulum or, on a much larger scale, the three planes of symmetry of an elliptical galaxy; an introduction and references are given in [29].

In section 2 we present the framework of our analysis by indicating how symmetry assumptions affect resonance and the normal forms. We use Birkhoff–Gustavson normalization which is equivalent with averaging techniques. In section 3 we give a new sharp estimate of the size of the resonance domain at higher order resonance.

Section 4 focuses on a special resonance, the 1 : 2-resonance for symmetric potential problems; we discuss an example from an important family of potential problems for which applications abound. The classical example is the Hénon–Heiles problem [12] which applies not only to axisymmetric galaxies but also to nonlinear chains as in the Fermi–Pasta–Ulam problem; see [8]. Molecular dynamics uses such two degrees of freedom formulations, for instance in [17, 24]. In mechanical engineering many examples can be found in [16]; see also the treatment of the spring-pendulum in [5].

Section 5 discusses one of the classical mechanical examples with symmetry, the elastic pendulum. This system has played a part in applications in aeronautical engineering [9, 20], celestial mechanics [18], astrophysics and aeronautics [13, 14, 18], and biology [2, 19]. In this problem, we show that the symmetry assumption produces a new hierarchy of resonances in which, after the well-known 2 : 1-resonance, the 4 : 1-resonance is the most prominent one. The asymptotic analysis is supplemented by numerical calculations which show excellent agreement.

2. Higher order resonance triggered by symmetry. Consider the two degrees of freedom Hamiltonian

$$(2.1) \quad H(p_1, q_1, p_2, q_2) = \frac{1}{2}\omega_1(p_1^2 + q_1^2) + \frac{1}{2}\omega_2(p_2^2 + q_2^2) + H_3 + H_4 + \dots,$$

with H_k , $k \geq 3$, a homogeneous polynomial of degree k . We introduce a small parameter ε into the system by rescaling the variables by $q_j = \varepsilon\bar{q}_j$, $p_j = \varepsilon\bar{p}_j$, $j = 1, 2$, and divide the Hamiltonian by ε^2 . We can define successive nonlinear coordinate (or *near-identity*) transformations that will bring the Hamiltonian into the so-called Birkhoff normal form. In action-angle variables, a Hamiltonian H is said to be in Birkhoff normal form of degree $2k$ if it can be written as

$$H = \omega_1\tau_1 + \omega_2\tau_2 + \varepsilon^2 P_2(\tau_1, \tau_2) + \varepsilon^4 P_3(\tau_1, \tau_2) + \dots + \varepsilon^{2k-2} P_k(\tau_1, \tau_2),$$

where $P_i(\tau_1, \tau_2)$ is a homogeneous polynomial of degree i in $\tau_j = \frac{1}{2}(p_j^2 + q_j^2)$, $j = 1, 2$. The variables τ_1, τ_2 are called actions; note that if Birkhoff normalization is possible, the angles have been eliminated. If a Hamiltonian can be transformed into Birkhoff normal form, the dynamics is fairly regular. The system is integrable with integral manifolds which are tori described by taking τ_1, τ_2 constant. The flow on the tori is quasiperiodic.

In normalizing, it is convenient if we transform to complex coordinates by

$$\begin{aligned} x_j &= q_j + ip_j, \\ y_j &= q_j - ip_j, \quad j = 1, 2, \end{aligned}$$

with corresponding Hamiltonian $\tilde{H} = 2iH$. The idea of Birkhoff–Gustavson normalization is to transform H (we have dropped the tilde) so that the transformed

TABLE 2.1

This table presents lower order resonant terms which cannot be removed by Birkhoff normalization. The second column shows resonant terms in the general case while in the third column we have added the symmetry condition $H(x_1, y_1, -x_2, -y_2) = H(x_1, y_1, x_2, y_2)$.

$\omega_1 : \omega_2$	Resonant term	
	General Hamiltonian	Symmetric in x_2, y_2
1 : 2	$x_1^2 y_2, x_2 y_1^2$	$x_1^4 y_2^2, x_2^2 y_1^4$
2 : 1	$x_2^2 y_1, x_1 y_2^2$	$x_2^4 y_1^2, x_1^2 y_2^4$
1 : 3	$x_1^3 y_2, x_2 y_1^3$	$x_1^6 y_2^2, x_2^2 y_1^6$
3 : 1	$x_1 y_2^3, x_2^3 y_1$	$x_1^2 y_2^6, x_2^6 y_1^2$
1 : 1	$x_1^2 y_2^2, x_2^2 y_1^2$ $x_1^2 y_1 y_2, x_1 x_2 y_2^2$ $x_1 y_1^2 x_2, y_1 x_2^2 y_2$	$x_1^2 y_2^2, x_2^2 y_1^2$

Hamiltonian becomes

$$(2.2) \quad H(x_1, y_1, x_2, y_2) = B_k(\tau_1, \tau_2, \epsilon) + R(x_1, y_1, x_2, y_2, \epsilon),$$

where B_k is in Birkhoff normal form with k as high as possible ($\tau_j = \frac{1}{2} x_j y_j, j = 1, 2$). R is a polynomial which has degree of either $2k$ or $2k + 1$ in (x_1, y_1, x_2, y_2) . The terms R are also known as resonant interaction terms and H in this form is called the Birkhoff-Gustavson or resonant normal form. In this paper we will refer to the terms in R as resonant terms. For normalization one can use a generating function or suitable averaging techniques. See, for example, [1, Appendix 7] or [28, Chapter 11].

The presence of resonant terms of the lowest degree in the Hamiltonian determines until what order the normalization should be carried out. For example, consider the Hamiltonian (2.1) and assume there is a pair of natural numbers (m, n) such that $m/n = \omega_1/\omega_2$, where m and n are relatively prime. The resonant terms of the lowest degree are generally found in H_{m+n} ; $\omega_1 : \omega_2$ is said to be a lower order resonance if the corresponding resonant terms of the lowest degree are found in H_k with $k < 5$. If $m + n \geq 5$, the normal form (2.2) becomes

$$(2.3) \quad H(x_1, y_1, x_2, y_2) = 2i(B_k(\tau_1, \tau_2, \epsilon) + \epsilon^{m+n-2}(Dx_1^n y_2^m + \bar{D}y_1^n x_2^m)) + \dots$$

It turns out that some of the lower order resonances are eliminated by symmetry in which case m and n need not be relative prime. This is due to the fact that during normalization symmetries can be preserved. See, for example, [7]. In Table 2.1 we present a list of lower order resonances and its corresponding resonant terms of the lowest degree. The second column shows resonant terms in a general Hamiltonian system while the third column is for a Hamiltonian system with symmetry in the second degree of freedom, i.e., $H(p_1, q_1, -p_2, -q_2) = H(p_1, q_1, p_2, q_2)$. Except for the 1 : 1- and 2 : 1-resonances, the other resonances are affected by the symmetry assumption. For example, the 1 : 2-resonance in the general Hamiltonian has resonant terms of the form $x_1^2 y_2$ or $x_2 y_1^2$. These terms vanish because of the symmetry assumption. Thus, instead of these terms which arise from H_3 , the resonant terms in the normal form derive from H_6 in the form of $x_1^4 y_2^2$ or $x_2^2 y_1^4$.

It is also clear that symmetry in the second degree of freedom does not affect the 2 : 1-resonance. If we assume the symmetry is in the first degree of freedom, then this resonance will be affected while the 1 : 2-resonance will not. On the other hand, both the 3 : 1- and 1 : 3-resonances are eliminated as a lower order resonance by the symmetry assumption, no matter on which degree of freedom the symmetric condition is assumed. As in mechanics, one often has symmetries. This may also

explain why these resonances received not much attention in the literature. This is demonstrated clearly for the elastic pendulum in section 5. For the 1 : 1-resonance, symmetry conditions on any degree of freedom (or even in both) do not push it into higher order resonance.

3. Sharp estimate of the resonance domain. In a seminal paper [21], Sanders describes the flow of (2.1) for the $m : n$ ($m + n \geq 5$) resonance cases on the energy manifold as follows. Interesting dynamics of the flow takes place in the resonance domain which is embedded in the energy manifold. The resonance domain, which contains a stable and an unstable periodic solution, is foliated into tori on which the interaction between the two degrees of freedom takes place. The time-scale of the interaction is $\varepsilon^{-(m+n)/2}$ and the size d_ε of the resonance domain is estimated to be $O(\varepsilon^{(m+n-4)/6})$. This estimate is an upper limit, due to the approximation technique used there. Van den Broek [25, pp. 65–67] gave numerical evidence that the size of the resonance domain is actually smaller. In this section we shall present a sharp estimate of the size d_ε which we derive from a Poincaré section of the flow.

Consider the normal form of a Hamiltonian at higher order resonance as in [21] in action-angle variables

$$(3.1) \quad H = \omega_1 \tau_1 + \omega_2 \tau_2 + \varepsilon^2 P_2(\tau_1, \tau_2) + \cdots + \varepsilon^{m+n-2} (\tau_1^n \tau_2^m)^{\frac{1}{2}} \cos(\chi),$$

where $\chi = n\varphi_1 - m\varphi_2 + \alpha$, $m/n = \omega_1/\omega_2$; and $\alpha \in [0, 2\pi)$. Note that P_k is a homogeneous polynomial of degree k and it corresponds to the H_{2k} term in the Hamiltonian (2.1). Independent integrals of the system are $\mathcal{I}_1 \equiv \omega_1 \tau_1 + \omega_2 \tau_2 = E_0$ and $\mathcal{I}_2 \equiv P_2(\tau_1, \tau_2) + \cdots + \varepsilon^{m+n-4} (\tau_1^n \tau_2^m)^{\frac{1}{2}} \cos(\chi) = C$. We will use these two integrals to construct the Poincaré map.

The derivation runs as follows. First eliminate one of the actions, for instance by setting $\tau_1 = (E_0 - \omega_2 \tau_2)/\omega_1$. Then we choose the section by setting $\varphi_1 = 0$. Thus we have a section in the second degree of freedom direction which is transversal to the flow of the system. For simplicity, we put $\alpha = 0$. Substitute all of these into the second integral \mathcal{I}_2 and define $\tau_2 = (p^2 + q^2)/2$ and $\varphi_2 = \arccos(q/(p^2 + q^2))$. We then define $\mathcal{P}(q, p, \varepsilon) = \mathcal{I}_2$ and from (3.1) we know that \mathcal{P} has an expansion of the form

$$(3.2) \quad \mathcal{P}(q, p, \varepsilon) = \mathcal{P}_4(q, p) + \varepsilon^2 \mathcal{P}_6(q, p) + \cdots + \varepsilon^{m+n-4} \mathcal{R}(q, p, \varepsilon),$$

where \mathcal{P}_k is nonhomogeneous polynomial of degree k and \mathcal{R} is determined by the resonant term. For a fixed value of E_0 and ε , the contour plot of (3.2) gives us the Poincaré map.

The contour plot of \mathcal{P} mainly consists of circles surrounding the origin. This is due to the fact that in the equations of motion, the equation for the actions vary of order ε^{m+n-2} and the equation for χ of order ε^2 . This implies that for most of the initial conditions, the actions are constant up to order ε^{m+n-2} and only the angles are varying. This condition fails to hold in a region where the right-hand side of the equation for χ is zero or becomes small. Up to order ε^2 , the location of this region can be found by solving

$$(3.3) \quad n \frac{\partial P_2}{\partial \tau_1} - m \frac{\partial P_2}{\partial \tau_2} = 0.$$

In phase space, (3.3) defines the so-called resonance manifold and on this manifold there exist at least two short periodic solutions of the system (more if m and n are not relatively prime).

In the contour plot, these short periodic orbits appear as $2m$ fixed points (excluding the origin) which are saddles and centers corresponding to the unstable and stable periodic orbit. Each two neighboring saddles are connected by a heteroclinic cycle. Inside each domain bounded by these heteroclinic cycles, also known as the resonance domain, there is a center point. For an illustration, see Figure 5.1 in section 5. We approximate the size of this domain by calculating the distance between the two intersection points of the heteroclinic cycle and a straight line $p = \lambda q$ connecting a center point to the origin.

Suppose we found one of the saddles (q_s, p_s) and one of the centers (q_c, p_c) . Let $C_\epsilon^s = \mathcal{P}(q_s, p_s, \epsilon)$ and $C_\epsilon^c = \mathcal{P}(q_c, p_c, \epsilon)$. Since the integral \mathcal{I}_2 depends only on the actions up to order ϵ^{m+n-4} we have $C_\epsilon^s - C_\epsilon^c = O(\epsilon^{m+n-4})$. The heteroclinic cycles are given by the equation $\mathcal{P}(q, p, \epsilon) = C_\epsilon^s$ and the intersection with the line $p = \lambda q$ is given by solving $\mathcal{P}(q, \lambda q, \epsilon) = C_\epsilon^s$. Write $q = q_c + \epsilon^\nu \xi, \nu \in \mathbb{R}$. We want to determine ν which leads us to the size of the domain.

Since (q_c, p_c) is a critical point, we have $\mathcal{P}'(q_c, p_c, \epsilon) = 0$ where the prime denotes total differentiation with respect to q . We expand \mathcal{P} :

$$\mathcal{P}_4(q_c, \lambda q_c) + \epsilon^{2\nu} \frac{1}{2} \mathcal{P}_4''(q_c, \lambda q_c) \xi^2 + \dots + \epsilon^2 \mathcal{P}_6(q_c, \lambda q_c) + \epsilon^{2\nu+2} \frac{1}{2} \mathcal{P}_6''(q_c, \lambda q_c) \xi^2 + \dots = C_\epsilon^c + O(\epsilon^{m+n-4}).$$

Since $\mathcal{P}_4(q_c, \lambda q_c) + \epsilon^2 \mathcal{P}_6(q_c, \lambda q_c) + \dots + O(\epsilon^{m+n-4}) = C_\epsilon^c$, we have $\nu = (m+n-4)/2$ and conclude the following.

Size of the resonance domain: In two degrees of freedom Hamiltonian systems at higher order resonance $m : n$ with m and n natural numbers satisfying $m+n \geq 5$, a sharp estimate of the size d_ϵ of the resonance domain is

$$(3.4) \quad d_\epsilon = O(\epsilon^{\frac{m+n-4}{2}}).$$

Note that in cases of the presence of an appropriate symmetry, the 2 : 1-resonance, for instance, has to be viewed as a 4 : 2-resonance.

Of course, degeneracies in the normal form may change this estimate. It is interesting to compare this with a formal method to derive the size of a resonance domain, described in [28, section 11.7]. If we repeat the balancing method (method of significant degenerations) described there for our higher order resonance problem, we recover estimate (3.4).

4. A potential problem with symmetry. We will now study the 1 : 2 resonance in potential problems with a symmetry assumption. In the introductory section we listed a large number of different fields of application. From those we briefly discuss protein cluster modeling from a paper by Shidlovskaya, Schimansky-Geier, and Romanovsky [24] and the theory of galactic orbits as summarized by Binney and Tremaine [3]. Substrate activation of the formation of the enzyme-substrate complex can be considered as a classical (or potential) nonlinear mechanical system. In [24] the authors consider a two-dimensional protein cluster model with linear bonds, which is modeled as a mass suspended to walls by four springs as in Figure 4.1. The spring constants depend on the type of enzyme involved in the process. For small oscillations, it can be viewed as a potential Hamiltonian system with linear frequencies $\omega_1 = \sqrt{k_1 + k_3}$ and $\omega_2 = \sqrt{k_2 + k_4}$.

We rescale time to set one of the frequencies to be 1; we put $\omega_1 = 1$ and $\omega_2 = \omega$. The Hamiltonian with a potential, discrete symmetric in the second degree of freedom

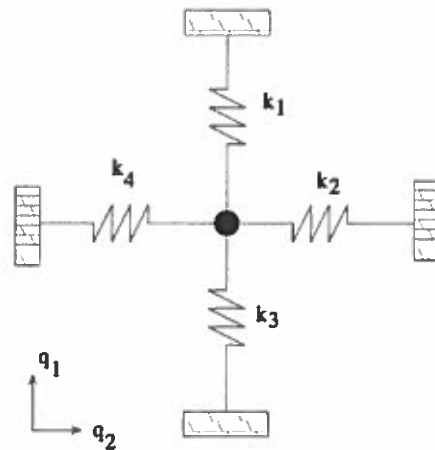

FIG. 4.1. The 2-dimensional model for protein cluster with linear bonds.

becomes

$$(4.1) \quad H = \frac{1}{2}(\dot{q}_1^2 + \dot{q}_2^2) + \frac{1}{2}(q_1^2 + \omega^2 q_2^2) - \varepsilon \left(\frac{1}{3} a_1 q_1^3 + a_2 q_1 q_2^2 \right) - \varepsilon^2 \left(\frac{1}{4} b_1 q_1^4 + \frac{1}{2} b_2 q_1^2 q_2^2 + \frac{1}{4} b_3 q_2^4 \right).$$

Assume $\omega^2 = 4(1 + \delta(\varepsilon))$. The reason for the assumption of the perturbation $\delta(\varepsilon)$ is that in applications we never encounter *exact* resonances; δ is an order function which is called the detuning to be specified later. In any case $\delta(\varepsilon) = o(1)$ as $\varepsilon \rightarrow 0$. We note that this is exactly the same as the system considered in [24] with symmetry condition ($k_2 = k_4$) and detuning parameter added. The symmetry assumption can be imposed by choosing the appropriate enzyme.

Another application involving the same potential problem (4.1) arises in the theory of three-dimensional axisymmetric galaxies; see [3, chapter 3] and [27] for the mathematical formulation and older references. Among these galactic orbits the so-called box orbits correspond with orbits outside the resonance manifold which behave like orbits of anharmonic two-dimensional oscillators. The closed loop orbits correspond with the periodic solutions in the resonance manifold; tube orbits are solutions in the resonance manifold which stay nearby the stable periodic solutions.

The unperturbed form ($\varepsilon = 0$) of the equations of motion derived from (4.1) is linear and all solutions are periodic. The periodic solutions in one degree of freedom only are called normal modes. The normal mode of the p_1, q_1 direction will be called the first normal mode and the other will be called the second normal mode. Using averaging techniques, we will approximate other (short) periodic solutions up to order of ε on a time-scale $1/\varepsilon^2$. Details of the averaging techniques and the asymptotic validity of the method can be found in [26] or [23].

4.1. The resonance manifold. To apply the averaging techniques, we transform the equations of motion into amplitude-phase form, by $q_j = r_j \cos(\omega_j t + \phi_j)$, $\dot{q}_j = -\omega_j r_j \sin(\omega_j t + \phi_j)$, $j = 1, 2$. The transformed equations of motion have average zero to $O(\varepsilon)$. This means that on the time-scale $1/\varepsilon$, both the amplitude and the phase are constant, up to order ε . If δ is of $O(\varepsilon)$, then there will be no fixed point in the averaged system and there is no interesting dynamics on this time-scale. Putting

$\delta(\epsilon) = \delta_1 \epsilon^2$, we perform second-order averaging which produces $O(\epsilon)$ approximations on the time-scale $1/\epsilon^2$; see [23].

We find for the approximate amplitudes ρ_1, ρ_2 and phases φ_1, φ_2

$$\begin{aligned}
 (4.2) \quad \dot{\rho}_1 &= 0 + O(\epsilon^3), \\
 \dot{\varphi}_1 &= -\epsilon^2 \left(\left(\frac{5}{12} a_1^2 + \frac{3}{8} b_1 \right) \rho_1^2 + \left(\frac{1}{2} a_1 a_2 + \frac{1}{15} a_2^2 + \frac{1}{4} b_2 \right) \rho_2^2 \right) + O(\epsilon^3), \\
 \dot{\rho}_2 &= 0 + O(\epsilon^3), \\
 \dot{\varphi}_2 &= -\epsilon^2 \left(\left(\frac{1}{4} a_1 a_2 + \frac{1}{30} a_2^2 + \frac{1}{8} b_2 \right) \rho_1^2 + \left(\frac{29}{120} a_2^2 + \frac{3}{16} b_3 \right) \rho_2^2 - \delta_1 \right) + O(\epsilon^3).
 \end{aligned}$$

From system (4.2), we conclude that, up to order ϵ the amplitude of the periodic solution is constant. This result is consistent with the result in [27].

We shall define a combination angle χ which reduces the dimension of the averaged system by one. Moreover, a lemma by Verhulst [22] (stated there without proof) can simplify the equation for the combination angle. We present this theorem in a slightly different form.

LEMMA 4.1. Consider the real Hamiltonian

$$H = \frac{1}{2}(p_1^2 + p_2^2) + V(q_1, q_2),$$

where $V(q_1, q_2)$ is analytic near $(0, 0)$ and has a Taylor expansion which starts with $\frac{1}{2}(\omega_1^2 q_1^2 + \omega_2^2 q_2^2)$. Then the coefficient of the resonant term D in the Birkhoff-Gustavson normal form (2.3) of the Hamiltonian can be chosen as a real number.

Proof. Assume $\omega_1/\omega_2 = m/n$, where $m, n \in \mathbb{N}$ and the Hamiltonian is in potential form as assumed in the lemma. By linear transformation the Hamiltonian can be expressed as

$$H = \frac{1}{2}\omega_1 (p_1^2 + q_1^2) + \frac{1}{2}\omega_2 (p_2^2 + q_2^2) + \sum_{k=3}^{\infty} \tilde{V}_k(q_1, q_2),$$

where \tilde{V}_k is the k th term of the Taylor expansion of V . Define a transformation to complex coordinates by $x_j = q_j + ip_j$ and $y_j = \bar{x}_j$. In these variables the Hamiltonian becomes

$$\tilde{H} = 2i \left\{ \frac{1}{2}(\omega_1 x_1 y_1 + \omega_2 x_2 y_2) + \sum_{k=3}^{\infty} \tilde{V}_k \left(\frac{x_1 + y_1}{2}, \frac{x_2 + y_2}{2} \right) \right\}.$$

Since the function inside the bracket is polynomial over \mathbb{R} we conclude that the Birkhoff-Gustavson normal form of the Hamiltonian is

$$(4.3) \quad \tilde{H} = 2i \{ P(\tau_1, \tau_2) + D(x_1^n y_2^m + y_1^n x_2^m) + \dots \},$$

where $\tau_j = \frac{1}{2}x_j y_j$, P is a real polynomial, and $D \in \mathbb{R}$. \square

- Generalization of this lemma is possible by considering a wider class of Hamiltonians by allowing terms like $p_2^{2s} q_2^k q_1^l$ (s is a fixed natural number, k and l are natural numbers) to exist in the Hamiltonian.

An important consequence of Lemma 4.1 is that in the equations of motion derived from the normal form of the Hamiltonian we have the combination angle $\chi = n\varphi_1 -$

$m\varphi_2 + \alpha$ with $\alpha = 0$. The phase-shift α will not affect the location of the resonance manifold; it will only rotate it with respect to the origin but it will affect the location of the periodic solutions in the resonance manifold.

Because of this lemma, define $\chi = 4\varphi_1 - 2\varphi_2$. Then, the averaged equations become

$$(4.4) \quad \begin{aligned} \dot{\rho}_1 &= 0, \quad \dot{\rho}_2 = 0, \\ \dot{\chi} &= \varepsilon^2 (\gamma_1 \rho_1^2 + \gamma_2 \rho_2^2 - 2\delta_1), \end{aligned}$$

where $\gamma_1 = -\frac{5}{3}a_1^2 + \frac{1}{2}a_1a_2 + \frac{1}{15}a_2^2 - \frac{3}{2}b_1 + \frac{1}{4}b_2$ and $\gamma_2 = -2a_1a_2 + \frac{13}{60}a_2^2 - b_2 + \frac{3}{8}b_3$. By putting the right-hand side of the last equation zero, the resonance manifold is given by

$$(4.5) \quad \gamma_1 \rho_1^2 + \gamma_2 \rho_2^2 = 2\delta_1.$$

This is equivalent with (3.3). The resonance manifold is embedded in the energy manifold and contains periodic solutions; because of Lemma 4.1 we know the location.

Using the approximate energy integral, i.e., $E_0 = \frac{1}{2}\rho_1^2 + 2\rho_2^2$, assuming $\gamma_2 \neq 4\gamma_1$ we can solve (4.5) for ρ_1^2 and ρ_2^2 as follows:

$$(4.6) \quad \rho_1^2 = \frac{2\gamma_2 E_0 - 8\delta_1}{\gamma_2 - 4\gamma_1} \quad \text{and} \quad \rho_2^2 = \frac{2\delta_1 - 2\gamma_1 E_0}{\gamma_2 - 4\gamma_1}.$$

We shall now discuss what happens at exact resonance ($\delta_1 = 0$). It is clear that $0 \leq \rho_1^2 \leq 2E_0$, so that we have $0 \leq \gamma_2/(\gamma_2 - 4\gamma_1) \leq 1$. The last inequality is equivalent with $\gamma_1\gamma_2 \leq 0$. If γ_1 tends to zero, then the resonance manifold will be approaching the first normal mode. For γ_2 tending to zero, the resonance manifold approaches the second normal mode. We exclude now the equality and will consider only the resonance manifold in general position. We summarize in a lemma.

LEMMA 4.2 (existence of the resonance manifold in general position for exact resonance). *Consider Hamiltonian (4.1) with $\delta(\varepsilon) = 0$. A resonance manifold containing periodic solutions of the equations of motion induced by this Hamiltonian exists if and only if $\gamma_1\gamma_2 < 0$. Those periodic solutions are approximated by $x = \rho_1(0) \cos(t + \varphi_1(t))$ and $y = \rho_2(0) \cos(2t + \varphi_2(t))$, where $\rho_1(0)$ and $\rho_2(0)$ satisfy (4.6) and φ_1 and φ_2 are calculated by direct integration of the second and the fourth equation of (4.2).*

- Using a specific transformation, we can derive the mathematical pendulum equation $\ddot{\chi} + \Omega\chi = 0$ related to the system (4.2); see [22]. The fixed points $\dot{\chi} = 0, \pi, \dot{\chi} = 0$ of the mathematical pendulum equation determine the locked-in phases of the periodic solutions by setting $4\varphi_1 - 2\varphi_2 = 0$ or $4\varphi_1 - 2\varphi_2 = \pi$. The first one corresponds with the stable periodic solutions and the second one with the unstable periodic solutions.
- From section 3 we know that the size of the resonance domain is $d_\varepsilon = O(\varepsilon)$, and the time-scale of interaction is $O(\varepsilon^{-3})$. Note that the size d_ε is in agreement with the work of van den Broek in [25].

4.2. Examples from the Hénon–Heiles family of Hamiltonians. An important example of Hamiltonian (4.1), with $b_1 = b_2 = b_3 = 0$, is known as the Hénon–Heiles family of Hamiltonians; see [27]. The condition for existence of the resonance manifold in exact resonance in Lemma 4.2 reduces to

$$\left(-\frac{5}{3}a_1^2 + \frac{1}{2}a_1a_2 + \frac{1}{15}a_2^2\right) \left(-2a_1a_2 + \frac{13}{60}a_2^2\right) < 0.$$

Assuming $a_2 \neq 0$ to avoid decoupling, we introduce the parameter $\lambda = a_1/3a_2$. Using this parameter, the existence condition can be written as $(450\lambda^2 - 45\lambda - 2)(360\lambda - 13) \leq 0$. Thus, the resonance manifold for the Hénon-Heiles family exists for $\lambda < -\frac{1}{30}$ or $\frac{13}{360} < \lambda < \frac{2}{15}$. Note that for the Contopoulos problem ($a_1 = 0$) the resonance manifold does not exist at exact resonance while in the original Hénon-Heiles problem ($a_1 = 1$ and $a_2 = -1$) the resonance manifold exists.

From this analysis, we know that for $\lambda = \frac{2}{15}$ the resonance manifold will coincide with the first normal mode. Since for $\lambda > \frac{2}{15}$ the resonance manifold does not exist, let λ decrease on the interval $(-\infty, \frac{2}{15}]$. The resonance manifold moves to the second normal mode which it reaches at $\lambda = \frac{13}{360}$. After that the resonance manifold vanishes and then emerges again from the first normal mode when $\lambda = -\frac{1}{30}$. The resonance manifold then always exists and tends to the second normal mode as λ decreases.

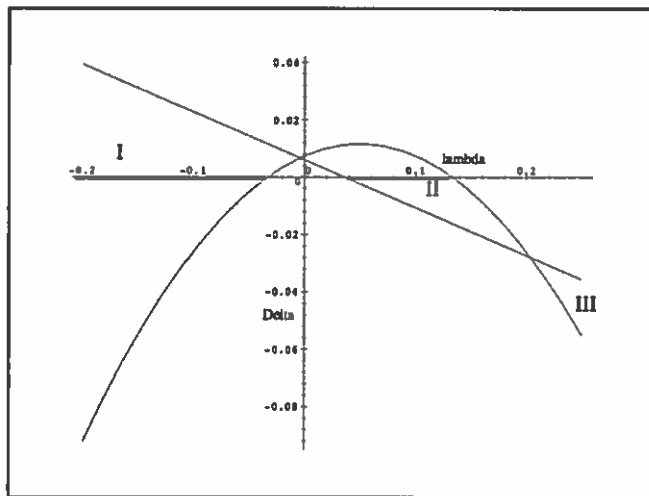

FIG. 4.2. Existence of the resonance manifold in the presence of (scaled) detuning parameter $\Delta = \frac{\delta_1}{E_0 a_2^2}$. The vertical axis represents Δ and the horizontal axis $\lambda = \frac{a_1}{3a_2}$. The domain II and the unbounded domains I and III (both bounded by the parabola and the straight line) correspond with existence of the resonance manifold.

How is the effect of detuning in the case of existence of the resonance manifold? In the same way as before, in terms of parameters λ and $\Delta = \delta_1/(E_0 a_2^2)$, we can write for the existence of the resonant manifold

$$(4.7) \quad 0 \leq \frac{-360\lambda + 13 - 240\Delta}{3600\lambda^2 - 720\lambda - 3} \leq 1.$$

In Figure 4.2, the areas marked by I, II, and III represent the domains of existence of the resonance manifold in the parameter space. The parabolic boundary of the domain represents the first normal mode (q_1, p_1 direction) and the straight line boundary the second normal mode. By fixing the detuning coefficient, we have a horizontal line on which we can move the resonance manifold from one normal mode to the other as we vary λ . The analysis can be repeated for fixed λ . The bold parts of the horizontal axes are the cases of exact resonance. Note that the intersection points are excluded as they correspond with the zero of the denominator in (4.6).

4.3. The degenerate case $\gamma_2 = 4\gamma_1$. Consider again the equations in (4.4). With the condition $\gamma_2 = 4\gamma_1$, equations (4.4) become

$$(4.8) \quad \begin{aligned} \dot{\rho}_1 &= 0 + O(\varepsilon^3), \\ \dot{\rho}_2 &= 0 + O(\varepsilon^3), \\ \dot{\chi} &= \varepsilon^2 (2\gamma_1 E_0 - 2\delta_1) + O(\varepsilon^3). \end{aligned}$$

System (4.8) immediately yields that at exact resonance there will be no resonance manifold. Another consequence is that there exists a critical energy $E_c = \frac{\delta_1}{\gamma_1}$ such that the last equation of (4.8) is zero, up to order ε^3 . It means we have to include even higher order terms of the Hamiltonian in the analysis.

From the normal form theory in section 2, we know that for the 1 : 2-resonance H_5 does not contain resonant terms. Thus the next nonzero term would be derived from H_6 . As a consequence, the equations for amplitudes and phases are all of the same order, i.e., $O(\varepsilon^4)$. It is also clear that in H_6 besides terms which represent interaction between two degrees of freedom (resonant terms), there are also interactions between each degree of freedom with itself (terms of the form $\tau_1^\alpha \tau_j^\beta$).

To avoid a lengthy calculation and as an example, we consider a problem where $a_1 = a_2 = 0$. From the condition $\gamma_2 = 4\gamma_1$ we derive $b_2 = 3b_1 + \frac{3}{16}b_3$. Then the last equation of (4.8) becomes

$$\dot{\chi} = \varepsilon^2 \left(\left(-\frac{3}{4}b_1 + \frac{3}{64}b_3 \right) \rho_1^2 + 4 \left(-\frac{3}{4}b_1 + \frac{3}{64}b_3 \right) \rho_2^2 - 2\delta_1 \right) + O(\varepsilon^3).$$

Introducing the critical energy E_c , we have a degeneracy in the last equation which gives an additional relation, i.e.,

$$\delta_1 = \frac{1}{2} \left(\left(-\frac{3}{4}b_1 + \frac{3}{64}b_3 \right) \rho_1^2 + 4 \left(-\frac{3}{4}b_1 + \frac{3}{64}b_3 \right) \rho_2^2 \right).$$

We also note that for $\delta_1 > 0$ the critical energy exists providing $b_1 < \frac{1}{16}b_3$.

We apply second order averaging to have an $O(\varepsilon^2)$ approximation on the time-scale $1/\varepsilon^4$. We find for the approximations

$$(4.9) \quad \begin{aligned} \dot{\rho}_1 &= -\varepsilon^4 \frac{3}{32} \left(b_1^2 + \frac{5}{32}b_1b_3 + \frac{3}{512}b_3^2 \right) \rho_2^2 \rho_1^3 \sin(\chi), \\ \dot{\rho}_2 &= \varepsilon^4 \frac{3}{128} \left(b_1^2 + \frac{5}{32}b_1b_3 + \frac{3}{512}b_3^2 \right) \rho_2 \rho_1^4 \sin(\chi), \\ \dot{\chi} &= \varepsilon^4 \left(\frac{3}{64} \left(b_1^2 + \frac{5}{32}b_1b_3 + \frac{3}{512}b_3^2 \right) \left(\rho_1^4 - \frac{1}{8}\rho_1^2 \rho_2^2 \right) \cos(\chi), \right. \\ &\quad \left. + \frac{3}{64} \left(-4b_1^2 + \frac{1}{2}b_1b_3 + \frac{1}{256}b_3^2 \right) \rho_1^4 + \frac{3}{64} \left(-46b_1^2 + \frac{1}{4}b_1b_3 + \frac{1}{128}b_3^2 \right) \rho_1^2 \rho_2^2 \right. \\ &\quad \left. + \frac{3}{64} \left(-44b_1^2 + \frac{1}{2}b_1b_3 + \frac{9}{64}b_3^2 \right) \rho_2^4 \right). \end{aligned}$$

It is clear that the analysis of periodic solutions obtained by setting $\chi = 0$ or $\chi = \pi$ runs along the same lines as in lower order resonance cases. Consider $\chi = 0$. The fixed point of the averaged equations is determined by the last equation of (4.9). Since we are looking for periodic solutions which are different from normal modes, we assume both ρ_1 and ρ_2 to be nonzero. Writing $\xi = \left(\frac{\rho_2}{\rho_1} \right)^2$ we obtain a periodic solution by solving the quadratic equation

$$(4.10) \quad a\xi^2 + b\xi + c = 0,$$

where $a = -\frac{33}{16}b_1^2 + \frac{3}{128}b_1b_3 + \frac{27}{4096}b_3^2$, $b = -\frac{81}{32}b_1^2 - \frac{3}{64}b_1b_3 - \frac{15}{8192}b_3^2$, and $c = -\frac{9}{64}b_1^2 + \frac{63}{2048}b_1b_3 + \frac{15}{32768}b_3^2$. Assuming that $b_3 \neq 0$, we have

$$\begin{aligned} a &= -\frac{33}{16}\kappa^2 + \frac{3}{128}\kappa + \frac{27}{4096}, \\ b &= -\frac{81}{32}\kappa^2 - \frac{3}{64}\kappa - \frac{15}{8192}, \\ c &= -\frac{9}{64}\kappa^2 + \frac{63}{2048}\kappa + \frac{15}{32768}, \end{aligned}$$

where $\kappa = \frac{b_1}{b_3}$. It is easy to see that $b < 0$. Note that both the magnitude and the sign of b_3 is not important. We can also consider $\frac{b_3}{b_1}$ instead if $b_3 = 0$. We calculate the discriminant $D = b^2 - 4ac$ and $-a, b$, and c being quadratic in κ —plot the function $D(\kappa)$ in Figure 4.3.

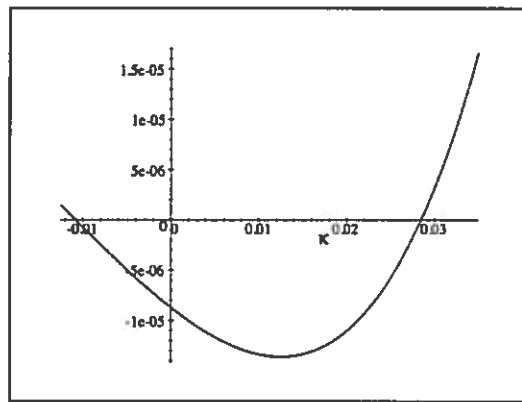

FIG. 4.3. Plot of $D(\kappa)$. Positivity of $D(\kappa)$ is a necessary condition for periodic solutions to exist of system (4.9) with $\chi = 0$, which are not normal modes.

There is an interval around $\kappa = 0$ where the value of D is negative. The value of κ so that D is zero can be calculated using numerics. Thus we know that except for small values of κ , we always have two roots for the quadratic equation (4.10). Knowing that we are looking for the root of (4.10) which is positive, we have to add another requirement. If we require c/a to be positive and b/a to be negative we will have two different periodic solutions. These requirements are satisfied by $\kappa \in (\frac{7}{64} - \frac{\sqrt{561}}{192}, \frac{1}{16})$. When κ is at the lower bound of the interval, the periodic solution coincides with the normal mode, in this case with the second normal mode. Note also that this interval contains the interval where the discriminant becomes zero or negative. The upper bound of the interval has to be excluded as a vanishes there. Thus if κ increases toward zero, the periodic solutions become closer, then coincide with each other and afterwards disappear. If we let κ increase from zero, at some point a periodic solution will emerge and split up by increasing κ . For $\kappa \in (-\frac{9}{176}, \frac{7}{64} - \frac{\sqrt{561}}{192})$ or $(\frac{1}{16}, \frac{7}{64} + \frac{\sqrt{561}}{192})$ there is only one periodic solution. This is reasonable since one of the periodic solutions coincides with one of the normal modes at the upper end points of each interval. It is easy to see that the case where a vanishes corresponds to the

existence of one periodic solution. For other values of κ the periodic solution does not exist. Note that we are considering only the case $\chi = 0$.

We have to apply the same reasoning to the other case and we expect conditions where there is no periodic solution (apart from the normal modes), or one, two, three, or four periodic solutions. Note that the analysis above also has to satisfy the existence condition for the critical energy, i.e., if $\delta_1 > 0$, the critical energy exists only for $\kappa < \frac{1}{16}$ and if $\delta_1 < 0$, for $\kappa > \frac{1}{16}$.

5. The elastic pendulum. In this section we will study one of the classical mechanical examples with discrete symmetry. Consider a spring with spring constant s and length l_0 , a mass m is attached to the spring; g is the gravitational constant and l is the length of the spring under load in the vertical position. The spring can both oscillate in the vertical direction and swing like a pendulum. This is called the *elastic pendulum*.

Let $r(t)$ be the length of the spring at time t and φ the angular deflection of the spring from its vertical position. In [26] van der Burgh uses a *Lagrangian* formulation to analyze the elastic pendulum, while in this paper we will use a Hamiltonian formulation. The Hamiltonian is given by

$$(5.1) \quad H = \frac{1}{2m} \left(p_r^2 + \frac{p_\varphi^2}{r^2} \right) + \frac{s}{2} (r - l_0)^2 - mgr \cos \varphi,$$

where $p_r = m\dot{r}$ and $p_\varphi = mr^2\dot{\varphi}$.

Introducing the elongation of the spring by $z = \frac{r-l_0}{l}$, we translate the origin of the coordinate system to the fixed point of the system where the elastic pendulum is hanging vertically at rest. By dividing by l we normalize the length of the spring; we adjust also the momenta $p_z = lp_r$ to keep the Hamiltonian structure. The Hamiltonian in the new variables is

$$(5.2) \quad H = \frac{1}{2ml^2} \left(p_z^2 + \frac{p_\varphi^2}{(z+1)^2} \right) + \frac{sl^2}{2} \left(z + \frac{l-l_0}{l} \right)^2 - mgl(z+1) \cos \varphi.$$

Put $\alpha_1 = \omega_z \sigma$ and $\alpha_2 = \omega_\varphi \sigma$, where $\sigma = ml^2$. We transform $\bar{z} = \sqrt{\alpha_1} z$ and $\bar{\varphi} = \sqrt{\alpha_2} \varphi$. To preserve the Hamiltonian structure we also transform $p_z = \sqrt{\alpha_1} \bar{p}_z$ and $p_\varphi = \sqrt{\alpha_2} \bar{p}_\varphi$. Expanding this Hamiltonian the two leading terms of the Hamiltonian are

$$\begin{aligned} H_0 &= \frac{1}{2} s(l-l_0)^2 - mgl, \\ H_1 &= \frac{1}{\sqrt{\omega_z \sigma}} (sl(l-l_0) - mgl) z. \end{aligned}$$

We define the coordinate such that the pendulum is at rest in $(p_z, z, p_\varphi, \varphi) = (0, 0, 0, 0)$. As a consequence the linear term of the Hamiltonian is zero. Thus we have $s(l-l_0) = mg$. This condition restricts the ratio of the frequencies of the two oscillators, i.e., $\omega_z/\omega_\varphi > 1$. The restriction is natural since at the equilibrium position the resultant force of gravitational force (mg) and spring force ($s(l-l_0)$) is zero. With $\sqrt{s/m} = \omega_z$

and $\sqrt{g/l} = \omega_\varphi$, the remaining terms in the expansion of the Hamiltonian are

$$\begin{aligned}
 H_2 &= \frac{1}{2}\omega_z(z^2 + p_z^2) + \frac{1}{2}\omega_\varphi(\varphi^2 + p_\varphi^2), \\
 H_3 &= \frac{\omega_\varphi}{\sqrt{\sigma\omega_z}}\left(\frac{1}{2}z\varphi^2 - zp_\varphi^2\right), \\
 H_4 &= \frac{1}{\sigma}\left(\frac{3}{2}\frac{\omega_\varphi}{\omega_z}z^2p_\varphi^2 - \frac{1}{24}\varphi^4\right), \\
 H_5 &= -\frac{1}{\sigma\sqrt{\sigma\omega_z}}\left(\frac{1}{24}z\varphi^4 + 2\frac{\omega_\varphi}{\omega_z}z^3p_\varphi^2\right), \\
 H_6 &= \frac{1}{\sigma^2\omega_\varphi}\left(\frac{1}{720}\varphi^6 + \frac{5}{2}\left(\frac{\omega_\varphi}{\omega_z}\right)^2z^4p_\varphi^2\right), \\
 &\vdots
 \end{aligned}
 \tag{5.3}$$

As expected, the—relatively few—terms in the Hamiltonian are symmetric in the second degree of freedom and also in p_z . Due to the restriction of the frequency ratio above, we will not have the 1 : λ -resonances with $\lambda > 1$. On the other hand, the symmetry condition on the second degree of freedom eliminates the 3 : 1-resonance as a lower order resonance. The next resonant term of this resonance arises from H_8 . Thus, for lower order resonances, the remaining cases are the 2 : 1- and, if we allow small detuning, the 1 : 1-resonance. The 2 : 1-resonance has been intensively studied; see [26] or [16]. This resonance is the one with resonant terms of the lowest degree.

As noted in [26], for the 1 : 1-resonance, second order averaging still gives only zero for both the amplitudes and the phases. (This is not rendered correctly in [29].) It follows that the 1 : 1-resonance is also eliminated as a lower order resonance. The reason for this degeneracy is simple; by defining $x = r \sin(\varphi)$ and $y = r \cos(\varphi)$ we can transform (5.1) to

$$H = \frac{1}{2}m(\dot{x}^2 + \dot{y}^2) + \frac{g}{2}(x^2 + y^2) - mgy.$$

This means that for the 1 : 1-resonance we have the harmonic oscillator in which all solutions are periodic with the same period. Thus we have isochronism. Let us now assume that $\omega_z/\omega_\varphi \neq 1$.

Introduce the transformation $z = r_1 \cos(\omega_z t + \phi_1)$, $p_z = -r_1 \sin(\omega_z t + \phi_1)$, $\varphi = r_2 \cos(\omega_\varphi t + \phi_2)$, and $p_\varphi = -r_2 \sin(\omega_\varphi t + \phi_2)$. Assuming $\omega_z \neq 2\omega_\varphi$ and rescaling with ϵ as usual we find the second-order averaged equations for amplitudes and phases

$$\begin{aligned}
 \dot{\rho}_1 &= 0 + O(\epsilon^3), \\
 \dot{\rho}_2 &= 0 + O(\epsilon^3), \\
 \omega_\varphi \dot{\psi}_1 - \omega_z \dot{\psi}_2 &= -\epsilon^2 \frac{3}{4} \frac{(\omega_\varphi - \omega_z)(\omega_z^2 + \omega_z \omega_\varphi - 3\omega_\varphi^2)}{(\omega_z + 2\omega_\varphi)(2\omega_\varphi - \omega_z)\sigma} \rho_1^2 \\
 &\quad + \frac{1}{16} \frac{(\omega_\varphi - \omega_z)(\omega_z^3 + 13\omega_z^2 \omega_\varphi + 20\omega_z \omega_\varphi^2 - 28\omega_\varphi^3)}{\omega_z(\omega_z + 2\omega_\varphi)(2\omega_z - \omega_\varphi)} \rho_2^2 + O(\epsilon^3),
 \end{aligned}
 \tag{5.4}$$

where ρ_1 and ρ_2 are the approximations of r_1 and r_2 and ψ_1 and ψ_2 are the approximations of ϕ_1 and ϕ_2 , respectively. The resonance manifold is determined by the requirement that the right-hand side of (5.4) vanishes. This implies the resonance manifold exists for all resonances with $\omega_z/\omega_\varphi > (\sqrt{13} - 1)/2 \approx 1.30277\dots$ (We exclude the 2 : 1-resonance and small detuning of it.)

We will now consider the most prominent higher order resonances which are possible for the elastic pendulum problem. We start with the 3 : 2- and the 4 : 1-resonance. For both resonances we know that in general the resonant terms arise

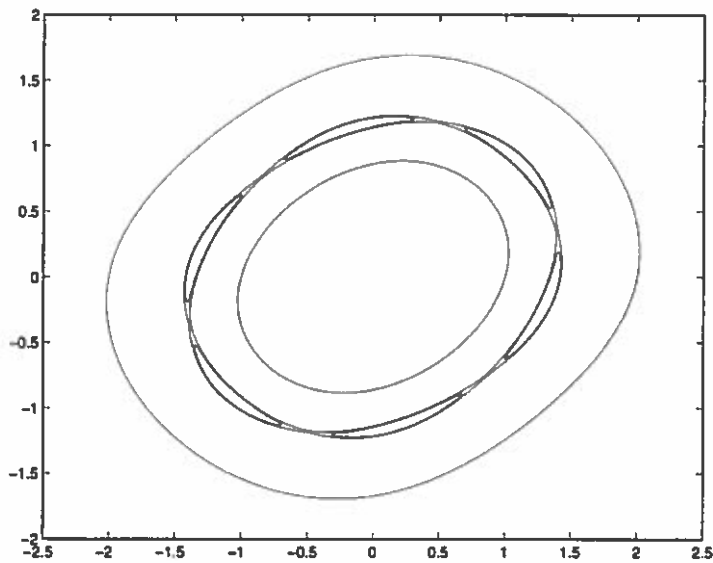

FIG. 5.1. The Poincaré map for the 6 : 1-resonance in the second degree of freedom ($\epsilon = 0.75$ and the energy $E = 5$; large values for illustration purposes). The saddles are connected by heteroclinic cycles and inside the cycles (islands) are centers.

from H_5 which implies that the amplitude variation will be zero up till second order averaging. This is in agreement with (5.4). To determine which resonance in the elastic pendulum arises from H_5 , we have to normalize.

TABLE 5.1

This table presents the most prominent higher order resonances of the elastic pendulum with lowest order resonant terms H_k . The third column gives the size of the resonance domain in which the resonance manifold is embedded while in the fourth column we find the time-scale of interaction in the resonance domain.

$\omega_x : \omega_\theta$	Resonant part	d_ϵ	Interaction time-scale
4 : 1	H_5	$\epsilon^{1/2}$	$\epsilon^{-5/2}$
4 : 3	H_7	$\epsilon^{3/2}$	$\epsilon^{-7/2}$
6 : 1	H_7	$\epsilon^{3/2}$	$\epsilon^{-7/2}$
3 : 1	H_8	ϵ^2	ϵ^{-4}
8 : 1	H_9	$\epsilon^{5/2}$	$\epsilon^{-9/2}$
3 : 2	H_{10}	ϵ^3	ϵ^{-5}

The result is, for the 3 : 2-resonance, that there is no resonant term in the normalized Hamiltonian up to degree 5. However, for the 4 : 1-resonance, there are resonant terms in the normalized Hamiltonian of degree 5. The conclusion is, after the first-order 2 : 1-resonance, the 4 : 1-resonance is the most prominent resonance in the elastic pendulum. Following the analysis in section 3, we can also determine the sizes of the resonance manifolds which depend on the lowest degree of resonant terms in the normal form. We repeat this for cases in which the resonant terms arise in H_7, \dots, H_{10} . The results are summarized in Table 5.1. Note that a low order resonance as the 3 : 1-resonance figures here at relatively high order.

We checked our result numerically for some of the resonances by constructing the Poincaré map and by calculating the size of the resonance domain. In the numerical

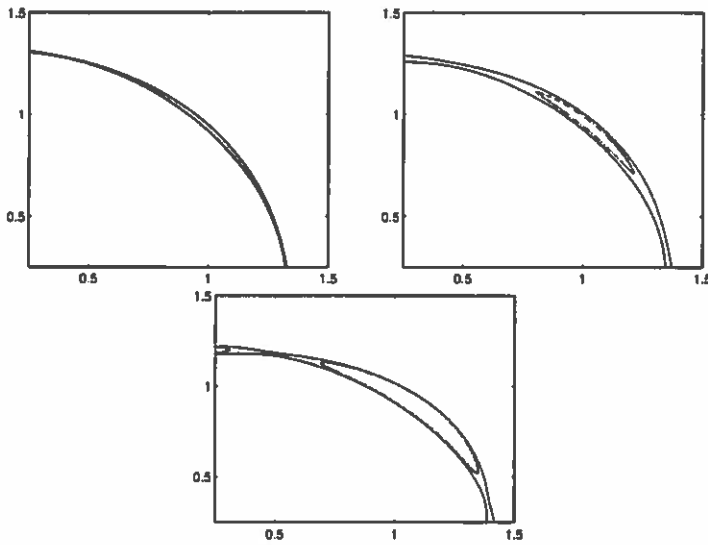

FIG. 5.2. The 6 : 1-resonance. Part of the map in the second degree of freedom direction for several values of ϵ , the energy $E = 5$. The top-left figure is for $\epsilon = 0.25$, the top-right figure is for $\epsilon = 0.5$, and the figure below is for $\epsilon = 0.75$.

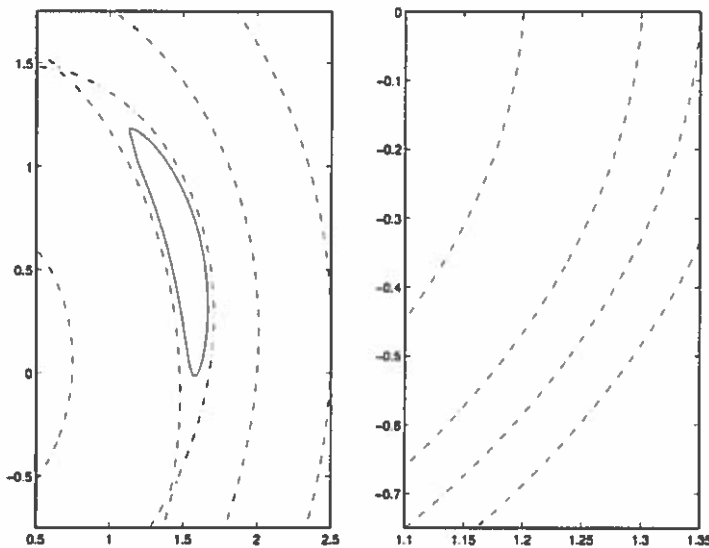

FIG. 5.3. Part of the map in the second degree of freedom direction for the 4 : 1-resonance (left) and the 6 : 1-resonance (right); $\epsilon = 0.1$ and the energy $E = 5$.

integrations we vary ϵ and study how this affects the size of the resonance manifold. We found confirmation for the 4 : 1-resonance and the 6 : 1-resonance, i.e., the numerical exponents are 0.4971... and 1.4991..., respectively. As Table 5.1 shows, the numerical integration takes a long time. Figure 5.1 shows the map for the 6 : 1-resonance. To avoid long computation times, we increased the value of ϵ . In Figure

5.2 we demonstrate the size and visibility of the resonance domain as ϵ increases for the 6 : 1-resonance. In Figure 5.3 the 4 : 1-resonance and the 6 : 1-resonance are compared.

6. Conclusion and comments.

- In nearly all real-life applications symmetries and hidden symmetries play an important part. We have mentioned a large number of examples. We have shown that (reflection) symmetry assumptions strongly affect some of the lower order and higher order resonances in two degrees of freedom Hamiltonian systems. In those cases, the symmetry assumption on one of the degrees of freedom implies a degeneracy in the normal form. This degeneracy forces us to extend the normalization as the resonant terms appear at higher order as compared with the case without symmetry assumptions. The conclusion is then that some of the lower order resonances behave like higher order ones. This makes sense since we know that, for instance, the 1 : 2-resonance can be viewed as 2 : 4-resonance or 4 : 8-resonance, etc.
- In the general, mathematically generic case, lower order resonance corresponds with strong interaction between the modes while higher order resonance corresponds with weak interaction, restricted to resonance domains. This happens, for instance, in a model for a protein cluster and in the theory of galactic orbits. For symmetric potential problems in 1 : 2-resonance, we have shown that at a certain critical value of the energy, localized in phase space at some distance of equilibrium, the system behaves like a strong resonance while for other values of the energy it produces higher order resonance. We note that the presence of this critical energy involves the detuning parameter. This is an intriguing new phenomenon and more analysis is needed to see what part this critical energy may play in applications.
- In applying the analysis to the elastic pendulum we have found a numerical confirmation of our analytic estimates of the size of the resonance domain. Also we have found a new hierarchy in the resonances due to two reasons: first, because of physical restrictions the $m : n$ resonances with $m < n$ are eliminated; second because of the symmetry assumption. As is well known the 2 : 1-resonance is the most prominent resonance, the next one turns out to be the 4 : 1-resonance. It turns out that the 1 : 1-resonance of the elastic pendulum is a rather trivial case.

Acknowledgments. J. M. Tuwankotta thanks Lennaert van Veen, Menno Verbeek, Luis M. Artiles, Bob Rink, and Martijn van Manen for many comments and discussions. J. M. Tuwankotta also thanks Santi Goenarso for every support during a difficult time.

REFERENCES

- [1] V.I. ARNOLD, *Mathematical Methods of Classical Mechanics*, Springer-Verlag, New York, 1978.
- [2] P.V. BAYLY AND L.N. VIRGIN, *An empirical study of the stability of periodic motion in the forced spring-pendulum*, Proc. Roy. Soc. London Sect. A, 443 (1993), pp. 391–408.
- [3] J. BINNEY AND S. TREMAINE, *Galactic Dynamics*, Princeton University Press, Princeton, NJ, 1994.
- [4] G.D. BIRKHOFF, *Dynamical Systems*, reprinted by AMS, Providence, RI, 1972.
- [5] H.W. BROER, I. HOVELUN, G. A. LUNTER, AND G. VEGTER, *Resonances in a spring-pendulum: Algorithms for equivariant singularity theory*, Nonlinearity, 11 (1998), pp. 1569–1605.

- [6] G. CIOGNA AND G. GAETA, *Symmetry and Perturbation Theory in Nonlinear Dynamics*, Lecture Notes in Phys., New Ser. m: Monogr. 57, Springer-Verlag, Berlin, 1999.
- [7] G. GAETA, *Poincaré renormalized forms*, Ann. Inst. H. Poincaré Phys. Theor., 70 (1999), pp. 461–514.
- [8] J. FORD AND G.H. LUNSFORD, *On the stability of periodic orbits for nonlinear oscillator systems in regions exhibiting stochastic behavior*, J. Math. Phys., 13 (1972), pp. 700–705.
- [9] A.H. FUJII AND W. INCHIKI, *Nonlinear dynamics of the tethered sub satellite systems in the station keeping phase*, J. Guidance and Control, 2 (1997), pp. 403–406.
- [10] M. GOLUBITSKY, I. STEWART, AND D.G. SCHAEFFER, *Singularities and Groups in Bifurcation Theory*, Vol. 2, Appl. Math. Sci. 69, Springer-Verlag, New York, 1988.
- [11] M. GOLUBITSKY AND I. STEWART, *Generic bifurcation of Hamiltonian systems with symmetry*, Phys. D, 24 (1987), pp. 391–404.
- [12] M. HÉNON AND C. HEILES, *The applicability of the third integral of motion: Some numerical experiments*, Astronom. J., 69 (1964), pp. 73–79.
- [13] D.L. HITZL, *The swinging spring-families of periodic solutions and their stability I*, Astronautics & Astrophysics, 40 (1975), pp. 147–159.
- [14] D.L. HITZL, *The swinging spring-invariant curves formed by quasi-periodic solutions III*, Astronautics & Astrophysics, 41 (1975), pp. 187–198.
- [15] V.V. KOZLOV, *Symmetries, Topology, and Resonances in Hamiltonian Mechanics*, Ergeb. Math. Grenzgeb. (3) 31, Springer-Verlag, Berlin, 1996.
- [16] A.H. NAYFEH AND D.T. MOOK, *Nonlinear Oscillations*, Wiley-Interscience, New York, 1979.
- [17] D.W. NOID, M.L. KOSZYKOWSKI, AND R.A. MARCUS, *Semiclassical calculation of bound states in multidimensional systems with Fermi resonance*, J. Chem. Phys., 71 (1979), pp. 2864–2873.
- [18] H.N. NÚMEZ-YEPEZ, A.L. SALAS-BRITO, AND C.A. VARGAS, *Onset of chaos in an extensible pendulum*, Phys. Lett. A, 145 (1990), pp. 101–105.
- [19] D.R. RIGNEY AND A.L. GOLDBERGER, *Nonlinear mechanics of the heart's swinging during pericardial effusion*, Amer. J. Physiol., 257 (1989), pp. H1292–H1305.
- [20] C.C. RUPP AND J.H. LAUE, *Shuttle/tethered satellite system*, J. Astronaut. Sci., 26 (1978), pp. 1–17.
- [21] J.A. SANDERS, *Are higher order resonances really interesting?*, Celestial Mech., 16 (1977), pp. 421–440.
- [22] J.A. SANDERS AND F. VERHULST, *Approximations of Higher Order Resonances with an Application to Contopoulos' Model Problem*, in Asymptotic Analysis, from Theory to Application, F. Verhulst, ed., Lecture Notes in Math. 711, Springer-Verlag, Heidelberg, 1979, pp. 209–228.
- [23] J.A. SANDERS AND F. VERHULST, *Averaging Method on Nonlinear Dynamical System*, Appl. Math. Sci. 59, Springer-Verlag, New York, 1985.
- [24] E.G. SHIDLOVSKAYA, L. SCHIMANSKY-GEIER, AND YU. M. ROMANOVSKY, *Nonlinear vibrations in a 2-dimensional protein cluster model with linear bonds*, Zeitschrift für Physikalische Chemie, 214 (2000), pp. 65–82.
- [25] B. VAN DEN BROEK, *Studies in Nonlinear Resonance, Applications of Averaging*, Ph.D. thesis, University of Utrecht, 1988.
- [26] A.H.P. VAN DER BURGH, *On the higher order asymptotic approximations for the solutions of the equations of motion of an elastic pendulum*, J. Sound Vibration, 42 (1975), pp. 463–475.
- [27] F. VERHULST, *Discrete symmetric dynamical systems at the main resonances with applications to axi-symmetric galaxies*, Phil. Trans. Roy. Soc. London, 290 (1979), pp. 435–465.
- [28] F. VERHULST, *Nonlinear Differential Equations and Dynamical Systems*, 2nd ed., Springer-Verlag, Berlin, 1996.
- [29] F. VERHULST, *Symmetry and integrability in Hamiltonian normal forms*, in Symmetry and Perturbation Theory, D. Bambusi and G. Gaeta, eds., Quaderni GNFM, Firenze, 1998, pp. 245–284.